

The Ecovita Box Urine-Diverting Composting Toilet

www.ecovita.net

A few years ago, my friends who ran a retreat lodge in Baja California Sur, Mexico, asked me to design a composting toilet that was attractive enough to be used by guests but could be moved around. David Del Porto developed a system contained in a wooden box. We used a CITA Mexican Urine-Diverting Toilet (available from Ecovita), but it can just as easily be used with a Separett Privy Kit (also available from Ecovita; www.ecovita.net). You can even make your own urine diverter with a funnel, but once you've used the easy, attractive and ergonomically correct Privy Kit, you won't go back!

Here they are the plans for this simple toilet. This one uses a 5-gallon bucket inside; I've used a 40-gallon plastic bin with aeration holes covered with insect netting. But this will work. My friend who wrote up and took photographs forgot to send photos of the urine tubing and vent stack. More photos will be added as we have them. - Carol Steinfeld at Ecovita

Overall Dimensions

Width 31"

Depth 24"

Height 18 1/2"

Sides: 18" x 24 "

Front and back panel 18" x 30 "

Seat side of top panel 20" x 24"

Vent side of top panel 11" x 24"

Vent Hole 4 1/8" dia.

Seat hole template provided with Privy Kit packing box.

Materials

18 linear ft. 2"x 2" Douglas Fir

One 4' x 8' sheet 1/2" or 5/8" plywood

AND one half sheet of same.

(note: one sheet will not make entire box)

1 1/4" drywall screws

Carpenters wood glue.

Basic power tools,

Screw gun, jig saw and or Skil saw

4" pipe for a vent stack

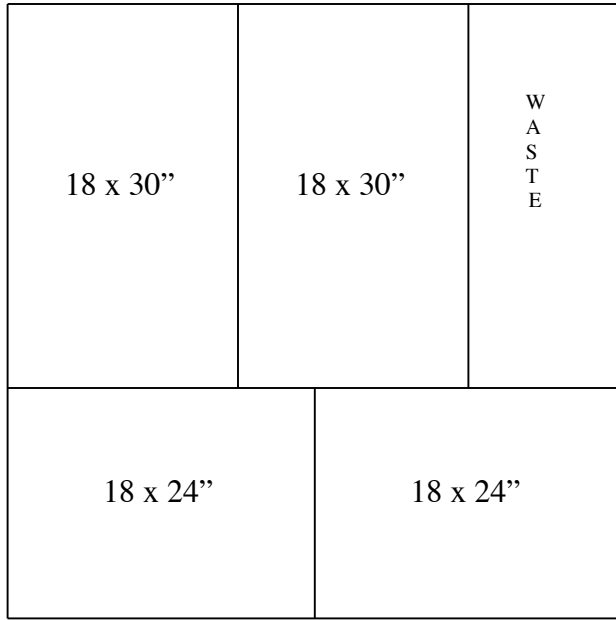

4 X 4' Plywood
Sheet - 1/2-5/8"

Cut as follows:

- 2 @ 24"x18"
- 2 @ 18"x30"
- save waste piece

[or, use a single sheet
of Plywood 4' X 6"]

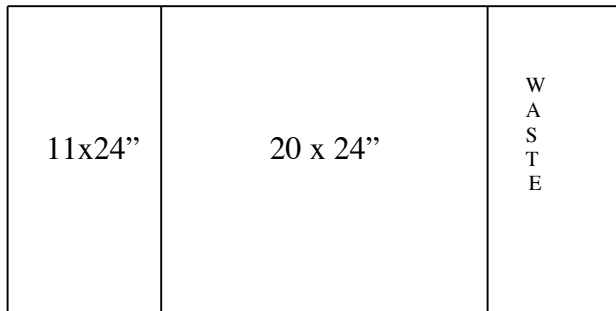

2 X 4' Plywood
Sheet - 5/8"

Cut as follows:

- 1 @ 11"x24"
- 1 @ 30"x24"
- save waste piece

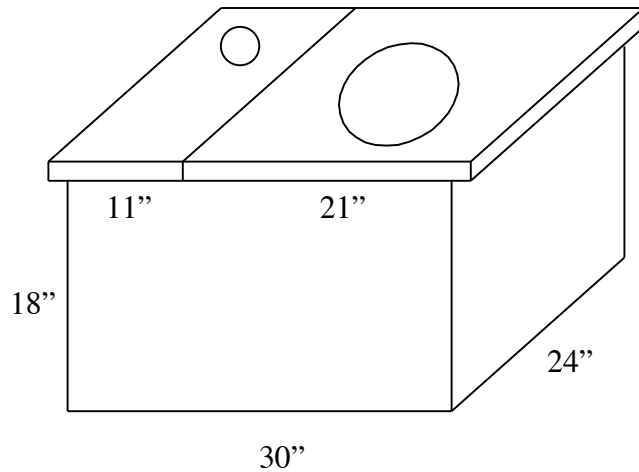

2x2" - 18 lin.ft., cut:

- 4 @ 30"
- 4 @ 15"
- 1 @ 21"
- 1 @ 6"

Schematic

Assembly:

Cut side and back panels from plywood. Attach 2" x 2" lumber around perimeter of front and back panels as shown in pictures.

Screw sides to front and back to make box structure.

Cut top panel to fit entire box top.

Measure 19" from inside of box side panel on front and back and attach a 2" x 2" strut across the top of the box at this point. This will provide a ledge for the vent panel top to fasten to.

Cut the top panel into two parts making sure when the panels are set on the top of the box the 2 x 2 supports the edge of each panel.

The top panels will measure approx.:

Vent side: 11" x 24"

Seat side 20" x 24"

Holes for seat and vent:

Mark a 4 1/8" diameter hole on the vent panel. The center of the hole will be located a third of the way back on the panel from the front edge of the box and in the center of the 11" dim. See photos.

Use template provided on Privy Kit box to trace pattern for seat. Place pattern so that front edge of foam seat is 3 to 3 1/2" from front edge of box. Cut hole with jig saw. See photos.

Fit dark blue separator element on hole in seat side of top panel. Attach with screws.

Attach vent panel to top over 2 x 2 strut.

Fit seat side of top next to vent panel. Attach scrap wood registration bars under seat to keep it from sliding on top. Scraps of 1" x 1" material can be used if hinges can be attached to back of seat panel. Note : hinges may make it more difficult to access waste holding bucket.

Fit blue foam seat cover over Privy Kit.

5 gallon bucket will fit under separator leaving room for vent attachment and urine hose to be attached to front bowl of diverter.





Two missing photos: A vent stack installed and the urine drain tubing.

Another variation:



Patrick Keaney has the Privy Kit drain directly into a 3-gallon bucket formerly used for olive oil.

Right: A closer, albeit blurry, view...
Solids drop to a 20-gallon plastic bin.

Or use with a urine-diverting toilet stool:

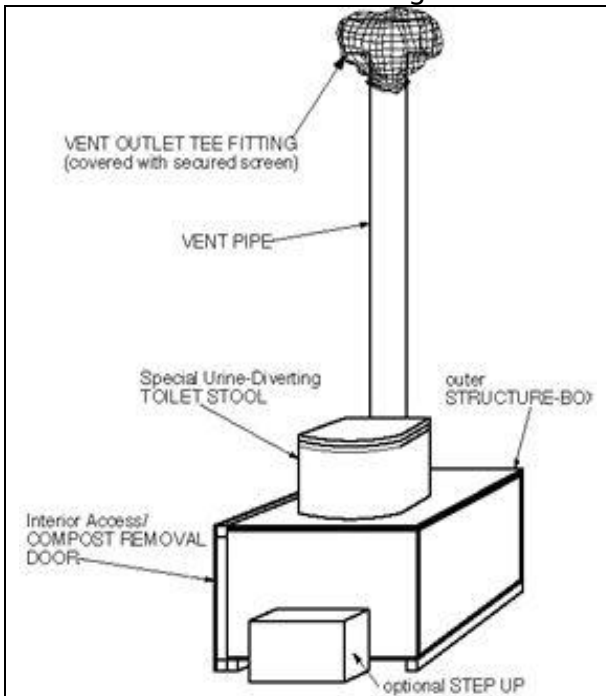

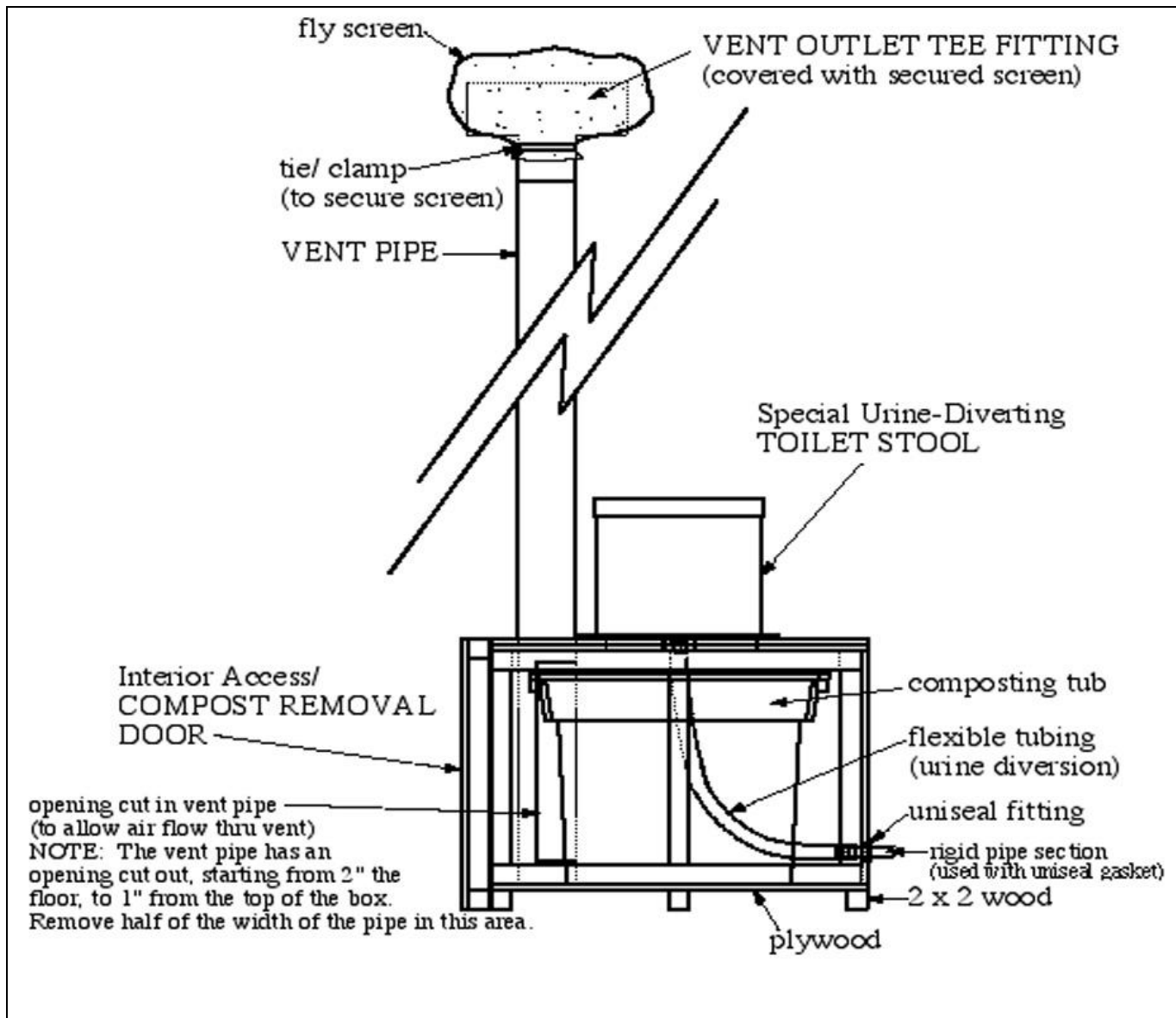

What to do with the urine?
Read:

