

WORLD IN TORMENT

A TIME WHOSE IDEA MUST COME

You will remember the beginning of humankind. Our first parents were quick to get themselves into trouble. They were expelled from the garden of Eden. I understand that Adam took Eve's hand, and said: 'My dear, we are living in a time of transition'.

Perhaps people have always felt like that. We certainly do today. Have you ever tried to list the components of contemporary change? It is easy enough to cite the marvels of modern science and technology - how the computer, and television, and medical science have changed our lives. If you start with such matters, it becomes a 'profound insight' to observe that there has been a change in the rate of change. But that was obvious twenty to thirty years ago, for I was writing books about it then.

Components of Contemporary Change

Today, my list is different. At the top is the spectacular advance in human misery. I estimate that more human beings are enduring agony today than ever before; the number could be greater than the sum of sufferers throughout history. I speak of starvation and epidemic; war and terrorism; deprivation, exploitation, and physical torture. I repeat the word agony; I am not talking about 'hard times'.

Second on my list is the collapse of the civilisation we have known in our lifetime. We are looking at the rubble that remains of two competing empires. Soviet communism has accepted its own demise; Western capitalism has not accepted it yet. But I am not making a forecast. I am examining the facts that are under our noses.

Out of 'political correctness', no one talks about the exploitation of either nature or indigenous peoples any more. They talk instead about 'sustainable development' - but there is no such thing. Not only can development not be sustained; even the existing fabric cannot be sustained any longer.

These two spectacular transitions, of human agony and societal collapse, are connected - not only at the phenomenal level, but in their etiology. It is not credible that most people prefer to live under these twin conditions. It follows that we are governed by an oligarchy - by the few; it is an oligarchy of power, greed, and terror. In the most extraordinary way, we are blind to this. To take the major example: none of the phenomena I have mentioned would be observed in their current and virulent form if there were no powerful modern armaments.

There are always pacifists around, thank God. But many friends tell me that pacificism cannot work in practice. Do not say this to me, who heard Gandhi speak in the flesh. It is not for nothing that his Sanskrit word **ahimsa** is so negatively translated as 'non-violence': **satyagraha** as its complement is not understood in the West at all. It means 'holding to the truth'. Ahimsa does not entail any lack of involvement or strong engagement. But no serious political platform anywhere has proposed to make the manufacture of armaments illegal. To the contrary, this manufacture is essential to the conduct of the existing world economy, and is the major instrument of vicarious foreign policy by those who command it.

The Diagnostic Approach of Managerial Cybernetics

What are we to say about the management that procreates this disastrous mess? Without jumping to conspiracy theories, or citing the illegal activities which now constitute the world's biggest industry, we can at the least say that humankind now manages its own affairs with breathtaking incompetence. This was not always so. Small tribes managed themselves very well indeed, and without destroying their habitats. Something has been going on that seems, at least in part, to be a function of size. Why should size make a difference?

Look at it this way. The number of internal relationships inside a complex system grows exponentially with linear growth in the system. And thanks to increasing complexity in the relationships detectable between the systemic elements themselves, induced by higher technology, we have been witnessing a variety explosion where the exponential function is itself an exponent. After centuries of riding on horseback, we have achieved speeds of 28,000 miles per hour: escape velocity. Each of us knows the dramatic change in the rate of change in computing - from the abacus to the chip. Over-ridingly, the population explosion seems to be hyperbolic, never mind exponential.

The variety, the measure of complexity, of the system we need to manage is a new universe of galaxies, compared with the single solar system we had to manage when the industrial revolution began. It has all happened within two hundred years. And surely that revolution was, in cybernetic terms, the coenetic variable to which we may trace systemic change in technology, economics, and the social order alike over the period.

What can the cybernetician, having recognised the coenetic variable, say about the management of this explosive transition, that is more than the sum of the relatively isolated analyses of technological, economic, and societal change management? First of all, the brain has not changed in this time. It remains, as McCulloch found it, a three-pound electro-chemical computer, running on glucose at 25 Watts. Even so, it had a very large number of elements: ten billion neurons, forsooth. It sounded a lot at the time, that is, in the nineteen-fifties. But now? Why, that's only ten gigabytes. Computers, if not brains, can handle that.

But here's the rub. In programming a computer, one needs a model. Models are provided by brains. Models are necessarily massive variety attenuators, because they select only those aspects of the world that are relevant to the model's purpose. Worse still, the models adopted are not the best that we can provide: they are consensual models put in place and held together by ideologies. And an ideology is a very low variety instrument indeed. Vast tracts of political philosophy since the ancient Greeks have been studied in common by the theorists of both communism and capitalism; but the ideologies to which the two superpowers rallied their supporters attenuated this variety in different guises. They have had this much in common: neither had Requisite Variety (as defined by Ashby's Law) by which to manage. Both are managerially dysfunctional therefore. And neither works.

To the political analyst, the two management systems are quite different, and to the politician wholly opposed. Neither side has had the least compunction in imputing moral judgements, and the rank and file have loved it. They have gone to both hot and cold wars about it. To the cybernetician, oddly enough, and starting from that common ancestor, the coenetic variable, much the same process has been going on. In a word, it is dysfunctional over-centrality.

A Summary Theory of Autonomy

According to the Law of Inter-Recursive cohesion, which I propounded in the seventies, it is a prerequisite of viability that a system should develop maximum autonomy in its parts, where maximum is defined to mean 'short of threatening the integrity of the whole'. Since you may not have encountered this work (more fully treated in Reference 1), let me depict any viable system as a cohesive whole having distinguishing parts like this:

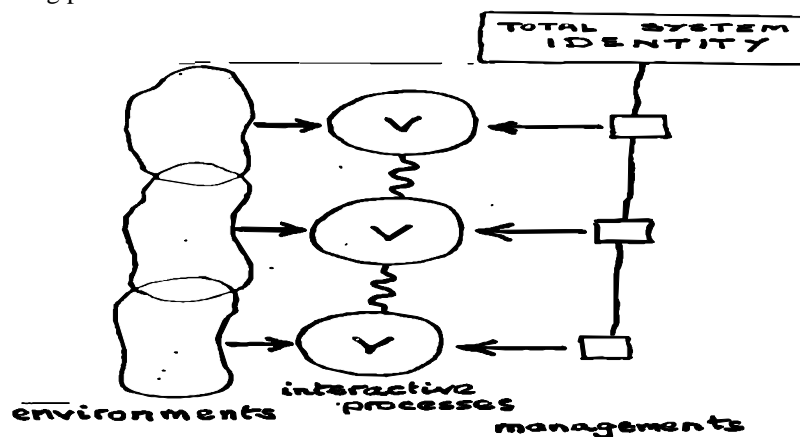

Figure 1

What is this whole? I am talking about a given societal unit: it could be a village or a company, a state or a multinational, a nation or the whole of humankind. What is systemic identity for this unit? It is a highly complex ethos of self-recognition, deriving from the interplay of many components - and in particular of the observed system with the multiplicity of its environments which, indeed, are major forces in formulating that ethos and forging that identity. These complications are discussed in the quoted reference; but we all know what we mean by acknowledging our nationality for example. It has connotations, of which we may be proud, and connotations of which we may be ashamed; it has connotations in other places which are gross, distortions of the reality that we recognise as home. What I say next assumes that we understand something about 'identity' - in all its complexification.

The process or activity that identifies each part of this identity is a circle marked with the measure of its variety, namely V. The management, depicted by the square box that impinges on the process, clearly has lower variety than the process itself. Management, after all, has to amplify its states in order to accommodate the process variety that proliferates around it. Similarly, the variety of the environment in which the process is embedded must be attenuated by some means if the process is not to be engulfed by the proliferating variety of its external world. In any given case, the situation is far more complicated, because we are dealing with continuous loops rather than simple connectivity's, and I have published detailed analyses (Reference 2) at length. But the essence of the Cohesion Law comes down to this. First of all we have:

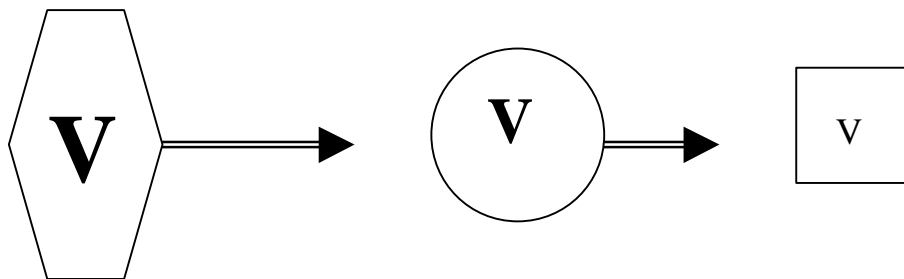

Figure 2

for each part of a viable system, where the differential sizes of V are intended as quantifiers. Then in order to obey Ashby's Law of Requisite Variety, regulators called amplification and attenuation must be in place, (I use the standard symbols from electrical engineering), so as to procure variety equivalence like this:

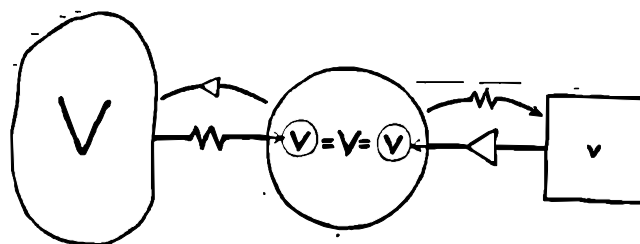

Figure 3

so that the three V's are of equivalent, and therefore requisite, variety. I have put emphasis on the central process and direct regulation (straight lines) for simplicity. In fact (as indicated by the curved lines) we are dealing as I mentioned with a pair of homeostatic loops which produce their effect by mixed regulative strategies. Note that I said that the regulators 'must be in place'. I say 'must' because we speak of a law of nature, whereby variety (just like water seeking its own level) tends to equate. Of course, we may not like the way in which this happens to occur, but we cannot prevent it. Managers may autocratically use threats or even guns as amplifiers of their own variety. And the most effective attenuator of environmental variety is often sheer ignorance within this subsystem of how the environment actually works. Management that is effective and ethical, however, will design the regulators, and put them in place.

I have written much about how to do this (Reference 2,3), but shall now return to the Law of Inter-Recursive Cohesion and the deployment of this elementary model. The task of managing the part, the horizontal component of Figure 1, is difficult because the managers do not start out with Requisite Variety. They need ingenuity and skills to put their regulators optimally in place. It follows that any intervention from above is likely to inhibit their professional practice. Even when intervention is deliberately designed to facilitate their on-site jobs, the policy or overall plan that intervenes cannot in principle have Requisite Variety in turn. The argument is the same as in Figures 2 and 3, turned through ninety degrees.

????? centralised management alike. ?????

Then why not leave the subsystemic parts to be self-organising viable systems in their own right? Well, if the original whole is to maintain its coherent identity, then the relations between the processes that the parts embody need to be continuously reaffirmed and that is the function of the squiggly vertical links depicted in Figure 1. Autonomy turns out to mean the maximum discretionary action for the part, short of threatening the integrity of the whole. This is a non-emotive definition of a very emotive term: freedom. I have been in trouble before for defining freedom as a computable function of the systemic purpose.

Please note the connections here. If the purpose of the system changes, then its identity is different. If its identity is different, then the relations defining its connected parts will be different. There is nothing in that so far which is not within the bounds of quiet evolutionary change. Indeed, I may claim to have given a cybernetic account of biological adaptation - which seems to apply to societies and species alike. It is, in my opinion, a start on the general process that characterises viable behaviour - a process slant on the general process identified by Humberto Maturana as autopsies (Reference 4).

But now I return to our current state of collapse. In the Soviet Union, the belief in central planning was quite clearly a repudiation of the Law of Inter-Recursive Cohesion. The higher level of recursion, which was the USSR itself with all its managerial and party appurtenances, undertook massive intervention in the autonomy of the parts. According to my analysis, even as so briefly given here, this was necessarily dysfunctional to viability. It is not relevant to decide whether this was well-intentioned intervention, nor whether its enforcement was ethically conducted. What is relevant is that the human, economic and social frustration of proper autonomy was bound to blow the system apart.

This is not said with mere hindsight. I argued this case with Eastern bloc scientists for many years. And, when I had the chance to help President Allende in Chile, twenty years ago, I designed a viable system that was completely autonomous as here defined.

The British Collapse

The collapse of Soviet Communism was formal, and it was heralded by the West in a spirit of vainglorious triumphalism. They were wrong; ergo we are right. But to say this one must blind oneself to the facts. As in the East, dysfunctional over-centrality has underwritten disaster: diagnosis uncovers the same cybernetic illness, only in the West the symptoms are different. And as often happens with mortal disease, people refuse to look at those disquieting symptoms.

I am British, and through the decade of the eighties I watched my country destroyed by an ideology. Investment in wealth-producing industry at home was denied in favour of international speculation, and the industrial base all but disappeared. Savings were eaten into by inflation, and by market manipulations that forced the price of housing, for instance, out of reach. Inner cities and urban infrastructure decayed; the army of the homeless was joined by large numbers of mentally deranged as health service was contracted; schools and universities were profoundly damaged by cuts. National assets that were publicly owned were sold off at bargain prices, and are steadily deteriorating. Income was redistributed, with huge increases going to the rich at the expense of the poor. Indeed, at the point when the proportion of people existing below the poverty line exceeded thirty percent, the government abolished the publication of that statistical index. Unemployment steadily increased, despite more than twenty changes in the method of calculation to make the situation look better.

So much for symptoms. This is no more than a thumbnail sketch. How have these symptoms been concealed? Well, of course, we have taken bitter medicine, and things will soon get better. Never mind

the cover-up of a spuriously prosperous and an absurdly over-valued pound that took too long to collapse in its turn. Immense sums were spent on international public relations in order, fairly successfully, to have a fake boom labelled an economic miracle. The creed of greed masqueraded under the respectable title of 'traditional values', but we are left with the rubble.

We are now ready to recognise the cybernetic process that impelled this disaster. The first variety attenuation that ran quite counter to British viability was the creed of greed itself. Never before had the great majority of Britons been persuaded that the only criterion that matters is wealth, or that money alone is its measure. Thus Philistinism, disregard of learning, contempt for the weak, and above all abandonment of the concept of the social good, came to be the marks of the decade. In proselytising egoism, the Prime Minister actually declared "There is no such thing as society".

This variety attenuation of values enabled a low variety managerial model to seem adequate. Monetarism, and its attempt to maintain stability through manipulating the money supply and interest rates, does not have Requisite Variety to maintain viability. The main reason for this is that the nation in all its locations and in all its facets generates far more variety than such an exiguous regulatory concept can encompass. The nation resists the attempt to define its identity simply in terms of gross national product, particularly when this is underwritten by 'funny money' generated between international exchange operators, and especially when what remains of value is inequitably distributed. A second reason for the failure of the government to control the money supply by not printing money to spend in Keynesian investment was that they embossed money on plastic instead. The promotion of greed was backed by the facilitation of credit, and it was this massive increase in indebtedness that promoted the fake boom.

Lacking Requisite Variety, the government's policies did not work. In cybernetic terms, there are two possible ways of restoring Requisite Variety. One is to enrich the identity of the nation by restoring to it the purposes it used to embrace. To do this, as we saw, the subsystemic relationships between aspects of society must be reinforced and desiderata other than money re-established. But this would contradict the ruling ideological paradigm. It follows that proliferating variety must be restrained, which can be done in terms of this analysis by decreasing autonomy. And that is exactly what happened.

The educational authorities and the health authorities that hold decentralised federal power in counties, municipalities and even villages, were an intrinsic part of the British way of life. They had Requisite Variety in local knowledge and insight; and their existence encouraged care and concern and voluntary action. They were virtually abolished, because they were divested of power; policy-making and planning were centralised in London. A national curriculum has been introduced, and school inspection privatised. Small hospitals have been closed as inefficient and London determines most aspects of health care delivery, including dentistry. This wholesale bureaucratisation conflicts with the ideology of individual enterprise. The ingenious if disingenuous way round this has been to urge medical practices and schools to opt out of the social framework that has characterised Britain, and commit themselves (still under central direction) to the profit-oriented definition of 'care'.

Again, this critique does not derive from hindsight. I launched it twenty years ago (Reference 5) and have often returned to the attack (Reference 6, for example), since. It is sad to watch the ideologies of the West refusing to accept the evidence of the rubble that was their culture; sadder still is the willingness of the East to sit at the feet of proven failure, to learn how to make the same mistakes - just as if there had been a success.

It is strange that two ideologies that have been billed as utterly opposed should both come to ruin from the same systemic disease: the loss of autonomy. Yet its inverse form, the seizure of power, is common enough in the history of humankind. Where does this always and inevitably lead? In the absence of a cybernetically sound structure for viability, what basic machinery underlies its unviable alternative? I want to propose one form, which I call chronic triage.

Autonomy at the Global Level

The centralisation of power in Britain has proved dysfunctional, just as it did in the Soviet Union. The difference is this. The strong sense of purpose in the dominant Communist Party generated a strong sense of identity in the Soviet Union. This was preserved by the loss of subsystemic autonomy, to the point where the whole system collapsed in an explosion that could not be denied. In Britain the strong

purpose of the ideological oligarchy set out to change the existing sense of identity, and did so by juggling with autonomy so as to alter subsystemic relationships.

The result was the same: the loss of freedom involved in diminished autonomy, and the ruin involved in dysfunctional over-centralisation. What is different is that Britain is still denying the truth, and can get away with it by claiming the possibility of recovery from a national indebtedness that it denies to its own parts as 'a matter of principle'.

I hardly dare mention the national indebtedness of the United States, which has the most cybernetically flawed organisation of the Western nations (although this is not quite its self-image). This exploding debt cannot in the long run be contained. In the attempt to service it, social penalties are being incurred that threaten the future of the American dream.

It would be entertaining if it were not tragic that when policies do not work, the oligarchy does not suppose that they are wrong policies, but decides that they have not been pursued with sufficient vigour-Britain has suffered greatly already from this mistakenly positive feedback, but proceeds to propel itself into a united Europe on the same lethal premises. We are already witnessing dysfunctional over-centralisation in Brussels, and it will get much worse. I go on record as a convinced European, a convinced World Citizen, indeed. But nothing can be achieved by organisations that are cybernetically flawed.

The ecumenical tendency to replicate these flawed structures and ruinous policies is most alarming. Power, as we saw, becomes concentrated, and the initiative is lost to local hands. Moreover, the time cycle of development is artificially shortened, and the market distorted to recognise only those needs that current technology determines to be economic. When we build at minimum cost per square foot, for example, we get boxes that are cheap - but may well be dysfunctional. There are practical matters of effective operation, of convenience, even of aesthetics that are of ten ignored in the economic equation. The biggest casualty of all under the creed of greed is the social good.

But Western Society obeys the economic diktat, which is uttered from the centre - from the central bank to the World Bank; from local budget provision to the International Monetary Fund. Which brings me to the United Nations, which ought to embody that social good for the sake of all humanity. Here we have an assembly of the whole world's nation states, each of which is in some sort of disarray. Yugoslavia has blown apart, having lost its Tito-empowered identity, and rediscovered its participant autonomy. As this process continues, whether in the strong form of the Soviet Republics, or the weak form of disunity that causes difficulties already in Britain and even Canada, the assembly of nations called the UN grows larger. If Africa were to disintegrate, so that natural tribal autonomies emerged as nations, replacing the artefacts of colonial invention, perhaps the roll call at the UN would quadruple overnight...

Now if we apply even the summary theory of autonomy on which this paper is based to the United Nations, we find the reverse situation from that so far discussed. The autonomy claimed by the nation states overwhelms in sum the variety displayed by the UN as an entity - if indeed it is an entity at all. It was breaking new ground when the Security Council managed to muster its variety together in the attempt to change the course of Iraq. The results were most disheartening to anyone who cares more about the agony of human beings than about the price of oil. I used the word triumphalism before; surely it is shocking that anyone should brag about the handful of lives lost in an operation that killed directly and indirectly a quarter of a million people.

The Cybernetics of Chronic Societary Triage

We manage through a model that we hold in our heads about how things work 'out there'. If our model does not have Requisite Variety, then we ought to incorporate learning circuits that will enrich it. But if we are ideologically attached to our model, so that it is not negotiable, and if we reject all contrary evidence, then it becomes a dysfunctional paradigm. Any oligarchy that has the power to enforce its ideology in this way will quite predictably give rise to triage.

Let me explain this term, and offer a cybernetic account of it. Triage comes from the French verb 'trier', to sort. In the early eighteenth century, triage meant the sorting of wool into various degrees of quality of the fleece. In the early nineteenth century, triage was the process of sorting coffee beans into

categories of the best, the satisfactory, and the worst - bad or broken beans. And the term 'triage coffee' referred to this worst category. A pejorative connotation had entered the usage; and the triage process had come to mean a sorting into three categories. Please note that the 'tri' in triage does not etymologically mean 'three': the threefold categorisation was a mere convenience.

Today, triage has an enlarged connotation. In a disaster, priority in treating casualties is given to those with the best chance of survival if given treatment. That is bad luck for the most afflicted; and contrary, indeed, to humanitarian instinct. But the hard decision, given limited resources, may have to be taken - these people are probably going to die anyway. Now I propose to extend this modern use of the word triage from discrete disasters (an acute condition) to a continuing state of affairs (a chronic condition). My argument will be to show why an ideological oligarchy in government tends to sort the people into categories, and with what expected results. Again I use three categories, just for convenience. The measures of variety are of course arbitrary too: no empirical estimates exist, and I am computing in terms of relative complexity.

In the following sketch, which is an approach toward a **Model of Chronic Societary Triage**, the basic conventions of the autonomy model are maintained. The letter V stands for a constant representing the (low) variety measure of the controlling ideology. x, y and z are modifiers that reflect the way in which societal categories A, B and C respectively represent the variety of the controlling ideology $v(i)$. The integer coefficients chosen, having no empirical basis, are strictly speaking ordinal numbers. Note however that they follow the basic Fibonacci series (1, 1, 2, 3, 5, 8, 13, 21, 34, 55). This is the common growth progression in biological systems; it typifies the expectation that additive growth leads to geometric development. Thus each number n in the series used is defined by $n = (n - 1) + (n - 2)$. Ordinal numbers unweighted (1, 2, 3, 4...) offer no sense of the increasing stress in the subsystems as disparity grows, whereas there is abundant evidence that social systems are under such stress - beginning (perhaps crucially) with the demographic stress of the population explosion itself, and continuing into epidemiological stress - whether physical (as with AIDS) or cultural (as with drugs). Suffice it to say that in the absence of empirical measures yielding cardinal numbers, ordinal numbers must be used instead, and that there is a basic scientific reason for 'intensifying' the series. It will not affect the argument if someone wishes to replace Fibonacci with a pet series of his/her own, so long as it recognises biological and sociological developmental facts.

Consider the Category A partition. This comprises, by definition, a management group that shares the ideological paradigm i , of variety v , which itself (and therefore) has variety equal to v , disposed on the horizontal axis by the Category A modifier x . We make the usual claim that the variety of the activity regulated must be higher than the management itself has available, call it $2v(x)$. The variety of the environment in turn must be higher still, and we call it $3v(x)$. Homeostatic loops are in place that amplify the lower varieties to absorb the higher varieties, and attenuate the higher varieties towards the lower varieties. Their 'mixed strategies' facilitate the Law of Requisite Variety, and induce transformations (marked T) that have the effect of reducing variety in all three blocks of the diagram to the basic variety $v(x)$.

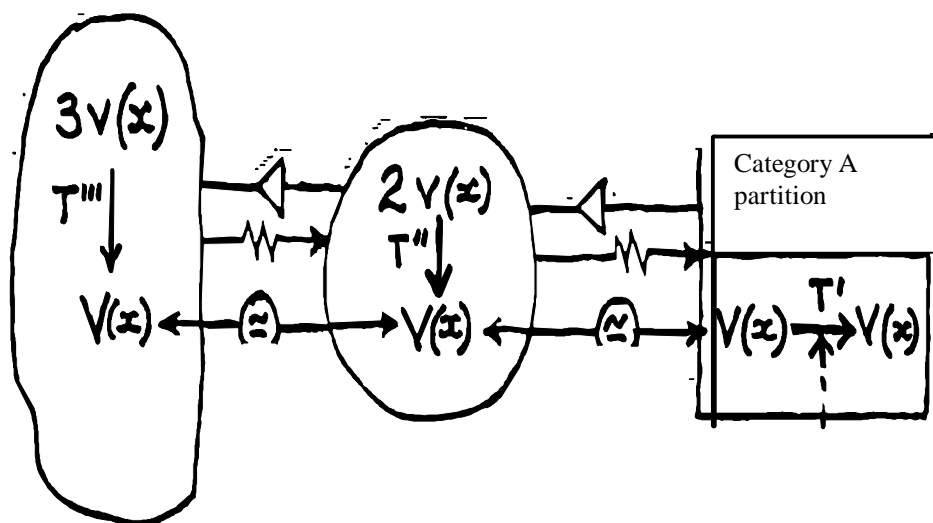

Figure 4 - Analysis of Triage: Category A Partition

The equilibrating process, indicated by the two meters for measuring approximate equality, feed into a comparator measuring error e , which generates a feedback function $f(e)$ to the management box. Note that the transformation on which it impinges generates an identity transform, since Category A was defined from the start as matching the controlling variety of the ideological paradigm. The effect of the feedback, then, is constantly to reinforce the identity $v(x)$, stabilising the complexity that the ideology recognises at the quantity v , and reaffirming the qualitative x -ness of A. This should have the outcome that the management box learns ever more effective ways of managing the homeostasis. This means in practice the continuous adaptation of design in the amplifiers and attenuators at P and Q, thus completing the learning loop. Note finally in Figure 4 that the vertical connections between the overall culture and the partition by definition exhibit Requisite variety, namely v . This vertical homeostat therefore operates without adjusters; and that very f act constantly reaffirms the shared ideology that defines Category A.

Category B does not share the ideology that it must nevertheless take into account - because the ideology controls the general culture. This necessarily places the horizontal system under stress. All components are struggling with the compromise between the official ideology and the pragmatic policies that they must pursue to remain B-viable. This is a fascinating process to watch - once one recognises, through Requisite Variety, what to look for. B-people are typically uneasy about the compromises that they make, and can be observed to wriggle under this duress. Many people in the West send their children to private schools because they confer privilege, despite disbelieving in the class and value systems that support them. Third World politicians accept the rules of the international economic game, although many suspect and will say privately that the entailed destruction of their indigenous culture is a tragedy. I agree with them, and am shocked at the willingness of the West to presume to teach low-variety ideological models that have already and demonstrably failed. With whatever mental reservations, however, B-people and politicians tend to go through the motions of compliance with the dominant cultural paradigm. Unhappily, when Category A status is fully secured, many forget the mental reservations that they made. They become genuine conformists. Then they begin to revel in the pay-off for inhibiting their personal or cultural variety. This is called corruption.

The Fibonacci coefficients 5, 8, 13 are used to make clear the consequences of not sharing, and to indicate that the complexity of the whole horizontal process is greatly increased. Because of the pragmatic compromise, the management box has (as it were) to 'run two sets of books'. One is accountable to its masters, and the other to its constituents. These constituents, in the process circle and in the environment, are subject to strong pressures by the management of the horizontal regulators of the two homeostats, since they must use more energy than Category A regulators to restore Requisite Variety with ideological conformity. The learning process generated through the feedback function $f(e)$ is correspondingly more severe, so that B-managers themselves will feel oppressed. The overall 'controllers', the cultural Establishment, characteristically make themselves alert to this. Wisely so, because the oppression nurtures the seeds of revolt. Thus the model posits a comparator that judges the continuous error e between the identity transform that stabilises ideological conformity for the culture itself, and the outcome of B-management's efforts to match it in Requisite Variety. The learning loop this time is closed through adaptation of the vertical regulators via the moderator R. Note that any deviations on the part of the B-partition result in louder, more stern commands from above, coupled with a decreased inclination to pay attention to the 'noise' of complaint from below.

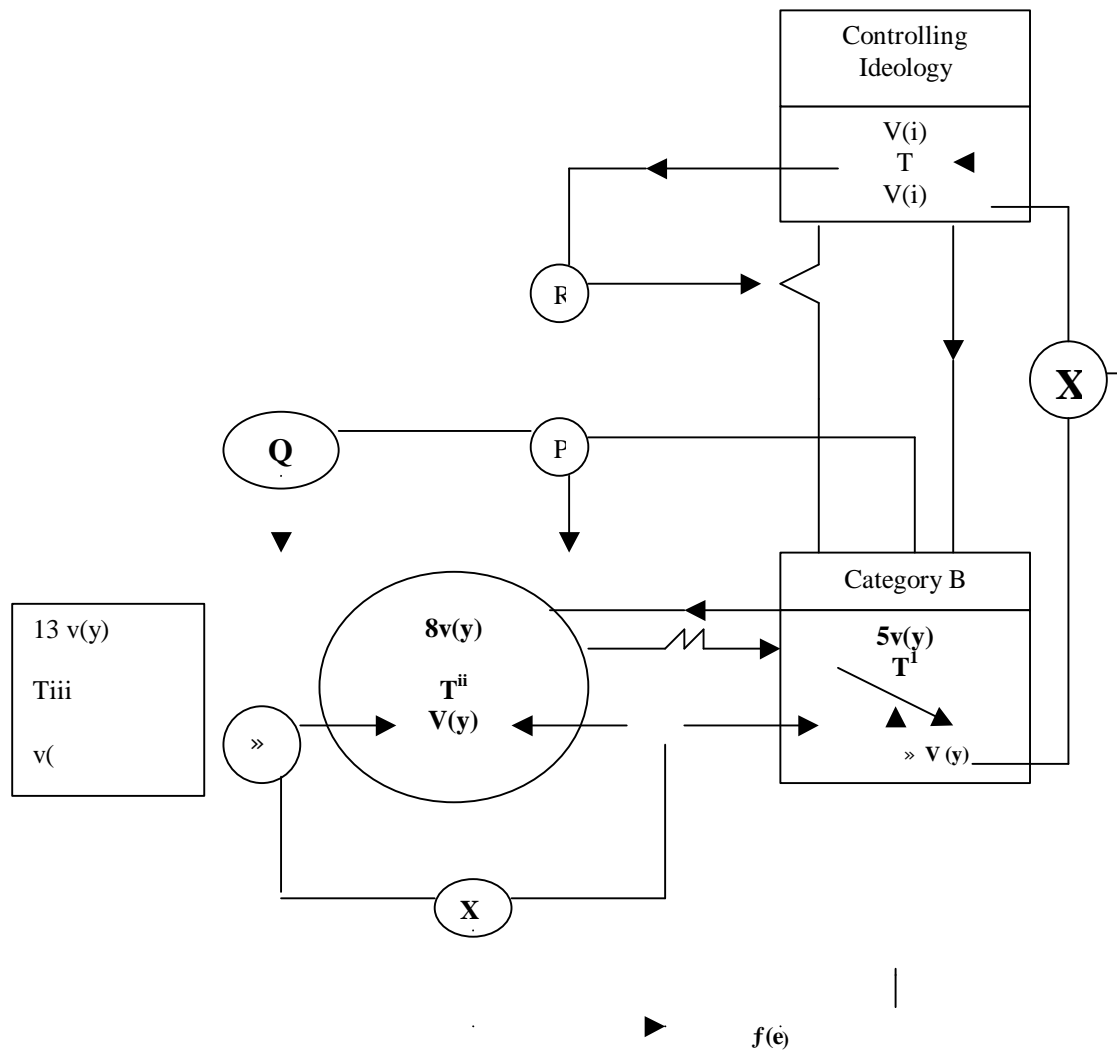

Figure 5

Analysis of Triage: Category B Partition

It is hardly necessary to draw a new figure to illustrate the plight of Category C, because it is structurally identical with the last figure, but see Figure 6 which includes it. The differences lie in the variety mismatches involved. The Fibonacci coefficients are now 21, 34, 55 - and it is this massive exacerbation of ideological inequality that puts Category C into the disaster mode. It is the triage subculture; and, because of the oppressive regulatory apparatus needed to stabilise the system at this level, disaffection and disjunction are inevitable. Moreover this is not an acute, momentary crisis. It is chronic dysfunction determined by the societal structure as defined. That is why it is idle to complain that the model has invented its own problems by choosing Fibonacci coefficients with explosive results. The loss of Requisite Variety is implicit anyway.

Allow me to repeat, because the point is commonly misrepresented: the Fibonacci series chosen to illustrate an observed behaviour of societal systems is not of critical importance. No one challenges the fact that large numbers of people constitute a badly disadvantaged section of society (we trip over them in the streets of London and Washington, and they starve in Somalia). No one denies the alienation of this section of society (the crime rate rises in Manchester and New York, and there have been rebellions against dictatorship all over the world at all times). Secondly, if the variety of the dominant paradigm is v , no one can deny that the variety at C is very much larger, because the excess variety takes so much containing - larger and more powerful police forces are only the start. But force, oppression, tends to be the dominant mode of containment, for the quite straightforward reason that the dominant ideology, manifestly-ostentatiously, lacks the legitimacy of consensual government. Are scientists to ignore the validated predictions of conceptual scientific models because the data are so far imprecise? If I say that a dead man weighed barely 100lbs, and a scientist weighs the body and its

weight is 102lbs. the man is none the less dead, and the 'mere theory' that he had too little to eat is not altogether discredited. Some members of the scientific confraternity prefer to complain about illustrations such as Fibonacci, and 'loose' measures of a variety which is clearly explosive, than to see whether cybernetic structures have something to tell us.

The next and final figure is given to facilitate discussion of the whole model. The reader is asked to supply the large portions of the schematic that s/he knows to be missing: those details are unchanged.

Figure 6 (to incorporate Figures 4 and 5)

Graphic Model of Chronic Societary Triage

Consider in more depth the role of the modifiers x , y and z , which were said to reflect the way in which the categories respectively represent the variety of the controlling ideology. Since variety is simply a measure of complexity (the number of possible states), it may not be clear why the systematic explosion of variety through the model is alleged to have a qualitative political importance. The reason is that the low-variety model is simplistic in the eyes of all those concerned in Categories B and C. It fails to accommodate or even to register the complications that they face in ordinary life. In a nutshell: folks whose children are starving do not accept that stealing food is wicked, although they know it is illegal. Then the enforcement of the ideology denies the opportunity to question it. The less dramatic version of this argument says that the dominant paradigm does not recognise such a thing as 'social good' at level C. People's lives are grossly affected by cutting bus services, manipulating apparently trivial prices, and so on " in ways unimagined at level A - all things done under the I more economic, excuse.

In the limit, which means in Category C, the "modifier" z will fail to modify. C-folk will have to work within a low variety model imposed from above which they do not see as at all relevant: that is to say they become alienated from society at large. A gap opens between B and C, which is soon a chasm. Upward mobility for C-folk becomes impossible, even if it were desired; and the C-environment becomes a sink into which B- failures descend. The cosmetic treatment of this socially disastrous gap is painful to observe. The pretence that the gap can be bridged to any important degree is fostered through high- profile 'examples' of such success: think of the arts (pop-stars, say) or sports (transfer fees, say). For most people, there is no hope.

The more C-folk are alienated, the more alienated they will become. This is because the vertical learning loop, based on error-controlled feedback generated at comparator E, uses its instrumentality R to put higher gain on the amplifiers and higher resistance into the attenuators (indicated by the doubling of symbols in the Diagram). This represents a strong positive feedback. The unification of society would call for negative feedback at this point, but the oligarchy calls that weakness: a loss of standards or a failure of resolve. It is a matter of observation that the undesirable positive reinforcement of alienation actually occurs. The disadvantaged often reject the help to which they are entitled - for instance, scholarships may be refused or welfare payments go uncollected, because the peer group pressure to remain lone of us' (victims) is strong, and the inertia of the bureaucratic process is too great for disillusioned people to overcome.

Then turn to the environments in which the processes of the three categories subsist. Insofar as the C-people are totally alienated, there is no interplay between their world and the remainder. There is only remote and perhaps envious observation, enhanced and distorted by the media (situation comedies, game shows, and so forth). Whereas there is an intersection (hatched) between the worlds of A and B in which membership is ambiguous; and, as the vertical arrows are meant to suggest, there is migration between them. People in the B-Category are not so far removed in variety from the dominant ideology that they have no hope of assimilating their modus vivendi into the lower-variety straitjacket of Category A. It pays them to try, because social benefits always accrue to those who work within the paradigm that designs and underwrites them. Backsliders in A, on the other hand, who increase variety by increasing behavioural options, lapse from the rigor of the shared ideology of A in so doing.

Unfortunately, Category C frequently pays penalties (for failing to uphold the ideology) to Category A. Category B also pays into A (to help it uphold the ideology). The B-people have a repugnance from C-people, and all the societal pressures exhibited by the model press for their upward mobility. For B's the fear of falling through the gap into C is threatening. They avert their eyes, therefore: serious confrontation of C-topics tends to be taboo. The B's sense of security and entitlement is often tenuous - which leads to self-censorship. They are likely to aspire to A-hood, in any case; but Category A resists the pressure in order to preserve privilege. Remember that the oligarchy is itself operating within Category A. Reflecting on the factors listed in this paragraph in the context of the model suggests sizes of A, B and C will tend to equate. The 'measure cannot be so crude as income per capita, nor the number of individuals included. It seems likely to be a weighted social statistical index of some kind, depending on the society under study. The point is that there will be a partition equivalence in societal terms that reflects the Requisite Variety of the cybernetic terms.

A final comment says that the triage constantly reinforces its own structure, and rapidly becomes indestructible except by main force. That is because, as I have many times shown (references 3,7), high-gain systems such as this have large negative real parts, and are soon dominated by their own feedback functions rather than by their inputs. In this case, after all, the feedback loops have been described as societal learning loops - which teach the system how to be itself and nothing else. Its structure is self-referential. Making changes in the inputs, therefore, will have little effect. And this goes a long way towards an understanding as to why social change is so difficult, and especially why liberal measures to alleviate suffering usually and typically fail.

The Bottom Line is Not the Bottom Line

The exposition of the triage model was introduced by reference to the internal worlds of the empires we used to call the superpowers, the USA and the USSR. In a world-wide context, it is easy enough to recognise Categories A and B in these two; and if so, there is little difficulty in placing the so-called Third World into Category C. There is no room here to analyse this classification in detail, but I invite you to do so. Note in particular, how the attempt to give economic aid from the rich world to the poor world has actually increased the "triage gap", in that there is a net outflow of wealth from the poor countries to the rich. Note that most B-folk are not aware of this: the averted eyes syndrome, perhaps; even so most people realise (especially those with personal computers) do not realise that they are impoverished of information because they are flooded with data. Note also how the attempt to impose the greed ideology through so-called 'development' leads to deficit and disaster- just as the model predicts. The World Bank and the IMF share the ideology, and the low variety models behind it.

Within an individual country, the triage is usually all too evident. In India, for example, the triage gap remains startling. Of course, it is actually institutionalised: the core group of the C-category is the harijan class. I was in the Indian army in the mid-forties as a young man. I left India on the 23rd of March 1947 - a significant date, for another Empire, the Raj, had just shut down. With joy, I truly believed that the harijan class would soon disappear. It was not until I elaborated the triage model forty-five years later, that is in 1992, that I understood my disappointment. There has been some social progress, I know, but it is very slow; and the structural triage is unaffected.

Meanwhile, in the Britain of the eighties, I watched the triage machine working with great effect. The ruling ideology was very strong, and of very low variety. Category B enjoyed a fake boom, and money was systematically siphoned out of Category C into Category A. When the percentage of people living below the poverty line passed thirty per cent, the government at last acted. They abolished the statistical index measuring the poverty line itself. Much the same thing is going on in the United States, and with similar impact on the poor, and on health, education and welfare generally. It has become an accepted truth that capitalist management is efficient, compared with the bureaucratic inefficiency associated with state enterprise. But anyone who has worked in the high echelons of big business knows this 'truth' to be false. S/he has experienced the 'Waste and Folly in the Private Sector' which subtitled a devastating indictment (Reference 8) by Herschel Hardin. This book should be required reading in every business school.

We are dealing with a triage pump. The As become steadily more advantaged, and the Cs more disadvantaged; and the trend continues. If my instinct about thirds is even roughly right, then we can

see why we have the trend, and why disastrous governments are re-elected. The As retain the government that favours them, and the Cs are powerless. The Bs hold the power balance; and they are bribed with consumer goods financed by ever mounting credit - plus the hope of leveraging themselves into Category A. The majority in a triage democracy is likely to opt for the status quo. An interesting contemporary phenomenon is that change is often embraced, because it is seen to be desperately required, and the tacit understanding that it will not involve any actual alteration. Governments tend to oscillate around a central political stance, so that 'left' and 'right' positions around that mean are almost indistinguishable. Tomorrow the new President Clinton will be inaugurated in the United States. He was elected on a platform demanding change. It remains to be seen whether anyone, the urban Black population for instance, will detect any difference. Since there has been no suggestion of restructuring anything, as distinct from massaging soreness, the model expects that the triage effect will leave conditions much as they are.

The theory advanced has isolated two features of the apparently triumphant culture that now dominates the world, which I allege will prove fatal to coherent civilisation. The first is the triage machine. In brief, this divides the world into categories (more than three may yet be identified) which condemn the lowest category nations to subjection by a controlling ideology that is now ecumenical in scope. The nations are increasingly defined in terms of chronic triage, and this has the effect (See Figure 6) of confirming their indigent identity by positive feedback. Within each separate nation, a recursive effect is observed: there is no real hope of rescuing the underprivileged category from the workings of the triage pump. The second feature is that this pump is primed by the motivation of greed, which respectable people call the profit motive.

Respectability in this sense is concerned with the conventions that underwrite identity, and with the materialism that drives the societary machine. Empirical evidence abounds. I began by drawing attention to the steady rise of misery and agony. The Category A or B nation-states allow this: they do not forswear the manufacture of arms, and they fail to distribute the world's super-abundance of food and medicine. It is left to small bands of dedicated volunteers to try to help. Harder than inefficiency is behind this: the triage derives from a structural flaw. Identically, at the nation-state level of recursion, respectable people sit at their dinner-parties discussing the 'problem' of thousands of abandoned children roaming the streets outside, with resort only to stealing or prostitution, and chronic societary triage determines that nothing can be done. Again, small bands of volunteers do their best to mitigate the hurt, but society itself is astoundingly detached. And yet, for the disadvantaged third of the nation, and the starving third of the world, and for all the good and caring people who share both national and international concern, which is to say in total more than half the people alive, the ruling ideology is not acceptable. For them, the bottom line is not the bottom line. They know there is such a thing as social good.

The Redundancy of Potential Command

We know in political terms why more than half the world is disempowered by low variety. In the kinds of democracies we run, which are better described as elective dictatorships, the individual is media-swamped by highly amplified low variety: s/he is robbed of voice, but moreover of intention.

Thanks to the work in neurocybernetics of the great co-founder of cybernetics, Warren McCulloch, we have the theory of the redundancy of potential command. He refined the theory from his studies of the human brain - which is not organised hierarchically, which has no underlying ideology, and which is not single-valued. The brain cells, or neurons, have much in common with the individuals who make up society. There are a great many, they are unreliable, and when they die they are replaced in their function by others. So the first thing is to say that neurons and people are organisationally redundant - highly redundant. This is not to disparage individual worth. It is only to say that graveyards are full of indispensable people. McCulloch reckoned that the brain is redundant in the order of 20,000 to one. People are often heard to say that this means that there is a lot of unused brain that could be developed to exhibit extraordinary powers. It is not the point: we need redundancy to make up for unreliability, dysfunction, and demise, and a society does too.

Although various regions of the brain normally deal with various recognisable functions, there is a lot of interchangeability that derives from redundancy. And in any case, brain functions are not localised and dedicated, as are functions in the management hierarchy of the firm or the state. So how are 'decisions taken', if they do not follow a given pathway up a given chain of command? The answer is

that a concatenation of neurons operates when and only when information collects that enables a reliable 'decision' to be made. Note that what I am calling a concatenation is defined from moment to moment by the presence of relevant information, and not by a preordained structure hungry for facts. Now the number of possible subsets of ten billion neurons is effectively infinite. This means that command is not prefigured, but is potential in any concatenation that shares the needful information. Let us call that an information set, an infoset. It is obvious that not only are individual neurons highly redundant, the infosets are too - since any infoset has the power of potential command.

It interested both McCulloch and me that the most successful human organisations, be they never so hierarchical in appearance, 'operate on an understanding of the redundancy of potential command. He analysed old battles, particularly those of Nelson, to demonstrate this. Sea mists and the smog of cannon fire made direct orders impossible to convey by signal flags, and Nelson's captains took command of whatever local situation they could actually see and interpret. I scan discovered the same phenomenon in industry. Who is really taking the decisions about computers? it is not the bigwigs who have to sign the requisitions, but a sub-cultural infoset of junior young people who know the latest technology. The Board pretends to understand, but is easily manipulated by those who know the facts.

This does not happen in our elective dictatorships, because it is not allowed to happen. I have formulated one of the mechanisms of censorship in the theory of chronic triage. The regulatory homeostats manipulated by mandarins and media prevent inconvenient facts from being properly understood by the people. The attenuation of political debate to mere 'sound-bites' began the process; today it is common to see a gesticulating image uttering no sound at all, while voice-over commentary claims to say what is happening. Again, there is increasing resort to plebiscite where a yes-no vote is recorded in relation to a complicated, high variety package of propositions. Notoriously, Napoleon III used the referendum to outflank the democratic process, and today it comes with a spurious claim to be democracy itself. It should scornfully be recognised as the government's mandate to repeal the natural Law of Requisite Variety.

Do we have to submit to these harsh facts? I answer that we do not, so long as we can identify infosets which have redundancy of potential command. Sovereignty does not lie with the nation state, but with the individual. Even political prisoners under torture have found the courage to maintain their personal integrity. Certainly ordinary sovereign citizens may maintain integrity; the problem is how to empower their use of it to political effect.

A Summary Theory of Team Syntegrity

For many years I have devised alternative models for the infoset, and protocols for its efficient operation. The first account of the definitive model was written nearly ten years ago, although it was first published in 1990 (Reference g). In the meantime, much experimental work has been done, and a book (Reference 10) is in course of preparation. This is not the place, then, to give full details, or to justify the choice of form. What follows is purely descriptive of a particular social invention. It does work efficiently already: what will be newly discussed in the next section is its relevance to a politics of potential command.

Please consider a group of five friends. No one is in charge of them. They have various interests in common, which is why they are friends. They talk about their interests - round the fire, walking in the park, over coffee, in the pub... If they discuss matters of moment to them, they might well come to a group insight, a crystallisation of ideas that might be labelled creative synergy. The insight might well include a plan of action to get something done, something that needs more than one activist to achieve. Figure 7 shows the five friends, and how they come together. The insight is pictured as emerging. at the centre of the group.

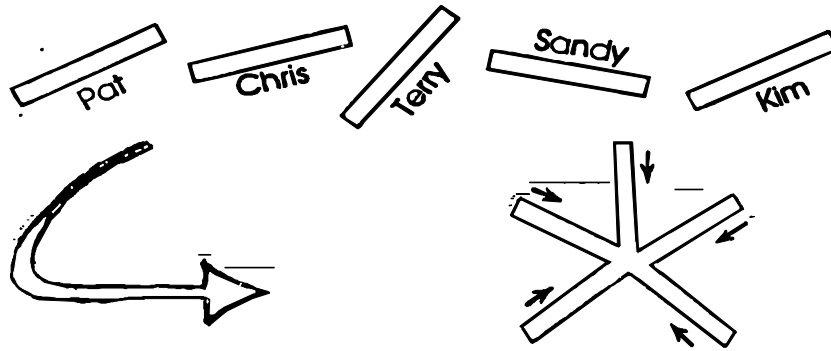

Figure 7

Creative Synergy: Five Friends Gather for a Serious Talk

Each of these people has other friends. Let us suppose that the focus of the information that the group developed is spread around a larger network of friends. An imaginary whistle blows by the time thirty people are involved: it is quite difficult to maintain an informational focus, especially if it is the source of action plans, with a number much larger than this. And if all thirty people arrange to meet, what are they going to do? Typically, people try to set up some kind of agenda. But that protocol means that in some sense what will happen is partly decided in advance, and even then the discussion is biased by the order of the agenda.

We could divide the thirty people into six groups of five, seeking to recapitulate the original process of creative synergy. Five people form an animated group, and everyone gets a chance to speak. Then, when the whole thirty meets, six rapporteurs might report in turn. This is a good idea, and versions of it are often used. But we were talking about integrity: the best way to generate synergy that is also integral is to close the network in upon itself. Then the thirty people are the struts that define the edges of an icosahedron.



Figure 8: The Icosahedron
 A: Featuring its Twelve Vertices
 B: Featuring the Internal Braces

This is itself a strongly banded organisational framework, depicted in diagram A of Figure 8. It is obviously not hierarchic: it has no top or bottom or sideways. Each person is a strut that forms an edge, and none can be differentiated from any other. Moreover, the model preserves the five-fold group with which we began. There are twelve such groups (the vertices of the icosahedron), and each person in this three dimensional network belongs to two of them. Think how ideas are free to buzz around, and to return to base - laden with honey. We have constructed a kind of social machine for generating not just six but twelve key foci of concern. Buckminster Fuller (Reference 10), for example, published posthumously) noted that all constructions in nature depend on forces of tension, as well as on the

compressive forces beloved of architecture. He so often used the phrase 'tensile integrity' that he shortened it to 'tensegrity' - and invented the geodesic dome on the strength of it (pun intended).

So far so good. But this structural model already clearly gains further strength if we can tack it together from inside. If we put in the connections such as the four marked in diagram B of Figure 8, we end up with thirty internal cross-braces. Each vertex is the root of five braces that connect it to five other vertices, each of which is one vertex removed from its nearest neighbours. If you wish to live inside a geodesic dome, you cannot clutter up the internal space in this way; but in a model of social integration no such problem arises. Even so, there are procedural and theoretical reasons for not representing the six major axes that connect the vertices from pole to pole.

The model now represents a maximal integration of the thirty-strong infoset, and it is well structured to maximise synergy too. Following the linguistic convention set by 'tensegrity', this structure is called a model of Team Syntegrity. It remains to specify how to turn this static structure into a dynamic process, and that is the task of Syntegration - a procedure governed by a special protocol. Each person finds that he is a member of two separate teams, trying to bring creative synergy to bear on a concern.

Each team is aided by five critics, appointed from other teams, and following the pattern of the braces that cross the internal space. A logic had to be developed to make a coherent allocation of critical resources that does not counter the requirement that every participant has exactly equal status. Then each person, a member of two teams, finds that he is a critic of two other teams. The logic also facilitates the self-organising of the whole group: there is no one who has authority to make appointments.

Ideally, it takes five days to carry through the protocol I have designed and validated by experiment for enabling all this to happen, and to generate action-directed outcomes. But, as shall be seen, it is possible to shrink the exercise to three days.

The Power and the Use of the Team Syntegrity Model

Something has to be said about the strength and power of Team Syntegrity. From an engineering standpoint, the strength is apparent. From an aesthetic standpoint, the structure is beautiful. But, as the fourteenth century builder Vignot said about the dome in Milan, "ars sine scientia nihil" - art without science is nothing (and the reverse is also true). So artists over the centuries have studied the five regular, convex, continuous Platonic solids that the Greeks extolled - the tetrahedron, cube, octahedron, dodecahedron and icosahedron, all of which can be contained inside each other, and generated by each other.

Geometric analysis of the icosahedron reveals a symphony of relational harmonies based on the Golden Section $a/b = b/(a + b)$. This ratio, when b/a is called x , yields the equation $x^2 - x - 1 = 0$. The positive root is $(1 + \sqrt{5})/2$, that is 1.618. Iterations of rectangles based on this ratio generate the logarithmic spirals that we find in biology, and the Fibonacci series we invoked earlier. Small wonder that these all-pervasive harmonies gave rise to the Pythagorean number-mystic, then the Hebrew Kabbala, and so on down the centuries.

The graph-theoretic mathematics of the syntegrity model advanced were first set out by Dr. Assad Jalali (Reference 11), and are discussed at length separately (Reference 12). The key insight, however, has to do with the reverberation of ideas within the syntegration process that every participant so far has noticed through experience. The model has thirty edges, twelve vertices, and a valency (k) of five. Then it is a k -regular symmetric, ergodic, connected graph of diameter three, that exhibits involutive automorphism. That sentence, though needing much explanation, is mathematically exact; and the last two words are helpfully evocative. For they suggest the self-consciousness that the reverberating infoset actually exhibits. Many years ago I learned from Heinz von Foerster that awareness depends on an eigenvalue which is the characteristic root of a particular kind of mathematical function that computes itself. That is what happens in the 'Staffordian Graph' here presented, where the eigenvalues relate to the j -5 derivative already seen to underlie the Golden Section.

Perhaps the most virile example of an infoset with which society is familiar is the directive management team of an enterprise. Take the leading directors of a company board; add the most respected staff aides; include (possibly) representatives of workers, clients and the community: here are thirty people strongly connected by a motive, a collegiate purpose. Can they afford to meet for an intensive five-day exploration of the future of their enterprise, using the Team Syntegrity model and protocol? If so, they may avail themselves of a service (See Note 1) set up for the purpose. If not, they are probably condemning themselves to years of orthodox, strung-out committee work that ties up thinking time, exhausts patience, frustrates innovation - and may be too late.

For societal purposes, however, we return to the image of a group of friends. These might indeed constitute a municipal council; they are more likely to be a loosely constituted gang of citizens, exercising their rights as sovereign individuals to try to get something done. If they are living in the same area, I call them a neighbourhood infoset. But perhaps they are not geographically contiguous. When Teilhard de Chardin wrote about the geosphere, the terrestrial world of rock, he saw it as enrobed in the biosphere, a multifarious but seamless web of life, which is in turn surrounded by a cloud of knowing - mind, the noosphere. Between the last two integuments I have inserted the technosphere - the infinitely differentiated network of modern communications. And a group of thirty like-minded friends, sharing a purpose but living well apart, may share their intentions and formulate their actions by electronic means via the technosphere. I call thirty such friends a global infoset.

World Syntegration: an Action Plan

You are now asked to set the team syntegrity model, the Staffordian Graph, in an ecumenical context that concerns itself with the redundancy of potential command.

There are people all over the world, sovereign individuals, who have ideas and purposes that they wish to share with others. They do not see themselves as bound by hierarchy (even to their own nation-states) or committed to the processes (even those called democratic) that demand the establishment of political parties, dedicated movements, delegations - or indeed high-profile leadership. These people are the material of infosets: neighbourhood infosets of thirty local friends, global infosets of thirty world citizens. Infosets of either kind formulate themselves, because they constitute potential command posts; they spread epidemically, demonstrating their redundancy; they interact massively, as is the nature of shared commitment. It is not a commitment to some shared manifesto, but a commitment to circumvent folly wherever it is found; it is a commitment to alleviate suffering; it is a commitment to brotherhood and peace.

This worldwide syntegration does not of course exist. It is a vision. But although visions may be inspirational, they do nothing much to alleviate suffering until inspiration is embodied in a plan of action. And if mounting human misery is the product of a triage machine as I have argued, and if the triage machine is endemic to the ruling world ideology so that it cannot be dismantled, then the action plan must circumvent triage altogether. The aim is ambitious: to start a process that invokes the redundancy of potential command as the methodology for a new system of world governance.

We have the seed: its germination requires that it be sewn in a nutrient medium on a sufficient scale that the plant takes hold and spreads. I seek to enlist the help of Key Collaborators to this end. It is not mere whimsy that asks for thirty such people to enlist, as will become clear. To mobilise action, we need a launch date for the endeavour: the week of 26th July 1993 has been nominated (See Note 2). The Programme is quite modest for the potency it ought to project. Imagine:

- (i) Thirty neighbourhood infosets meet for three days during that week, using a specially designed syntegrity protocol that will be provided for their use. These thirty meetings are in widely dispersed places around the globe: it would be good to have each continent represented.
- (ii) Thirty global infosets are operational over the five working days of that week, their exchanges borne electronically on the technosphere, using an electronic version of the Syntegrity protocol for which software will be made available.
- (iii) Each of the sixty remit for (in total) infosets has the same discussion:

- Isolate twelve key features that would characterise a world without triage to improve the lot of humankind;
- Express each in terms that indicate urgently required action;
- State in each case what action THIS INFOSET will; immediately undertake in furtherance of this willed future.

The infoset is absolutely in charge of its output, generated within the Syntegration protocol which is provided. There is one logical test that should be applied to every sentence:

- This sentence could be disputed without absurdity: that is, its negative is plausible.

“Feed the hungry” “heal the sick” “educate the ignorant” are injunctions that no sane person would dispute. Drop enough food by parachute to satiate the black market and rival armies so that plenty is left for ordinary folk; send the bill to the previous colonial power' is a substantive, because disputable, proposition.

(iv) An operations centre is in commission throughout the launch week in Toronto, Canada. Its task is to collect, collate and synthesise the 720 statements arriving from the 60 infosets. Note that 1800 people are simultaneously active in this manifestation of potential command. Press releases chart progress throughout the week.

Progress to what, if not to some sort of 'declaration' it is not the right question. We are trying to invent a societary learning system to replace the triage machine. If you stop the triage machine, freeze a frame, you capture the same categorisation - only the measures of misery get worse. If you enshrine pretended solutions in a Manifesto, you must begin to redraft it the day after it is adopted. If you enact a Constitution, experience shows that you must soon start passing Amendments. Twenty-five years ago, I coined the phrase 'the aborting ecumenical plan' (Reference 13, for example). The argument was that as soon as any corporate planning office had finally bound 'the Plan', and circulated it, new information arrived to make it obsolete. Therefore it must continually abort.

The same is true of any set of intentions that would bind world governance in a transitional age. What we need is a continuously aborting corporate plan that resolves into a fluid, adapting, programme of actions at all levels of society, that is in process of constant adjustment. Now freeze a frame: you have simply a snapshot of action-oriented thinking always under development, in continuing operational mode, sponsored by continuous syntegration on the part of all the redundant resources of potential command who care enough to join in.

Even the best of our democratic processes results in a consensus by the lowest common denominator. Continuous syntegration is expressive of the highest common factor. As an action-oriented procedure, it follows the fundamental rule of governance: do not decide on the next action until you have observed the outcome of the last action. McCulloch used to say that this rule embodied the quintessence of cybernetics.

Every proposition that emerges from the elaborate processes of Launch Week next July is logoi spermatikos. It is formulated to engender its own progeny. The final move of the week-long programme is designed to harness this life-giving energy to facilitate the propagation of continuous syntegration, thus,

- (v) Consider each set of thirty infosets, the one of neighbourhoods, the other of global sets. We conceive of each as the Staffordian Graph of its own thirty graphs. They are hypericosahedra.

Here is a graphic image of what this means. Take the twelve propositions of each infoset. The members decide which are the two most important, or most conveniently inclusive for what follows. Pull the icosahedron apart by these two vertices, so that the construction begins to disintegrate. Catch hold of each of the ten propositions as they fall away from the cohesive whole, and seek to incorporate it in one of the two chosen statements.

The first-generation icosahedra are now struts (edges) of a new Staffordian Graph, each carrying an enhanced proposition at each end. This means that each vertex of the second-generation hyperinfo set receives five inputs as starting propositions for its own syntegration.

The ordinary infoset has a protocol for generating its initial statements out of the minds of its members; these second-generation inputs are expressions of the group minds of its founding infosets. It is suggested that the human individuals who carry this through should be randomly selected, one each, from the original thirty infosets. It is vital, according to these principles, that they not be 'delegates', but free spirits who have learned from their initial syntegegration.

As happens with the generation of species, we should expect repeated generations of infosetters to form and to overlap in experience. But these are small societies, not individuals; and we should expect their membership to change according to the redundancy of potential command. The purpose of forming hypersets is not to create a hierarchy of warriors or of logical propositions that have enhanced status because they have 'risen to higher levels'. It is to make consolidated statements available that have been worked over by 900 people, 27,000 people and so on. My own expectation is that entropy in the language system and changing times will soon vitiate this "hyper-hype" of the process. It will fix its own limits. There is no prospect of gnarled ten-level syntegegrations formulating tenth-level propositions of unimaginable obscurity, emulating Hesse's Glass Bead Game. Potential command should see to that ... Alternatively, graph theoretic discoveries in the Staffordian Graph context may well result in an ability to formulate protocols that work n-dimensionally and therefore are not constrained to thirty infosetters at a time. We shall see.

In the meantime, our world-in-torment requires actions of every sort that might help to ameliorate the plight of millions. The triage model, however sketchy, powerfully suggests the need for structural change in the technique of governance. No established authority shows any willingness to undertake it. The non-hierarchic organisation that facilitates the redundancy of potential command is well founded in the example of all biological systems - in the brain outstandingly. Both the methodology and the technology are available to implement its societal analogue. No established authority, cowed by its own information technology, shows any willingness to explore it. Global syntegegration, however designed, is a necessity in the face of such inertia. The icosahedral model backs my own proposal for global syntegegration. But no one knows what it is, and the book (Reference 12) is fairly abstract. What we need is a start; a first demonstration, an ostensive definition, of what global syntegegration might look like, be and do. This is the purpose of the action plan. It is not grandiose, but practical. The proposal is directed in the first place to anyone with the courage to take a modest lead, and willing to be a pioneer of the Launch Week. I end by explaining what the role of Key Collaborator in that enterprise involves.

The Key is a colleague ready to accept responsibility as a Patron for Launch Week. S/he needs to be in a position to undertake two tasks: given that further information and all supporting documentation will be available months in advance. These are the tasks:

- **Become a patron of a neighbourhood infoset.**
Select someone well known to you who could organise a neighbourhood infoset. You would enthuse this leader, and "hold his/her hand". How is the net to be cast for volunteers - how do we implement the redundancy of potential command? How can the requirements for rooms and equipment (all fully specified) be met? The Key is not expected to run the infoset personally - but s/he is welcome to do so.
- **Become a patron of a global infoset**
This requires a computer part that can be made available for Launch Week, and a small team to man it - on a round-the-clock basis. This port is the pivot of a global group of thirty volunteers, - who are being recruited by the Toronto organisers. The port communicates results to Toronto as they are generated (there are several iterations of the process provided for in the protocol to be disseminated). Thirty volunteers will be allocated from Toronto to your port's infoset, aiming for a maximum dispersion worldwide. Of course the port team may recruit volunteers itself; but local volunteers who come to use the part facility will be allocated to other infosets. Again, the key Collaborator may wish to run this part personally, or simply to authorise its use.

Some of the thirty Key Collaborators have been recruited, and the plan hinges on their support. More are needed. Obviously, this is a scheme for realising Requisite Variety by local autonomies as earlier defined. A Project Director is already operating out of Toronto. Her name is Wendy Walsh. She has a big job to orchestrate thirty keys: 1800 individual infosetters are too many to co-ordinate directly.

The gap between the ambitions of this plan and the stark realities of the tormented world is vast. No action we take here can do anything about those realities in the short term. How easy it is to say (and many do): 'The world's not too bad, and we are working on a cure'. Nonsense: forty thousand children dying every day is bad enough, and the cure is not a genuine prospect. How easy, especially for us academic guardians of scientific probity to say (and many do): 'Hang on a bit. This needs toning down. Wait for proof, and the approbation of peers. My conscience will not permit such reckless use of science's fair name'. Such worthy folk cannot have taken the most fleeting look at the history of science, or of social innovation. I do not hesitate to remind this conference again, as I did six years ago in London (Reference 14), that Lord Kelvin, a President of the Royal Society (no less) when the century began, called heavier- than-air flying machines impossible, and opined that X-rays would prove to be a hoax. As to conscience, I agree with Oscar Wilde: "Conscience and cowardice are really the same things. Conscience is the trade name of the firm". I did say we needed courage.

Let us take comfort in the words of still another friend from whom it was my privilege to learn: she is almost uniquely qualified to give this encouragement. "Never doubt" said Margaret Mead "that a small group of thoughtful, committed citizens can change the world - indeed, it's the only thing that ever has".

That is true, is it not? The Buddha, the enlightened, is called Siddharta: "he who has fulfilled his purpose": but it was a small beginning, not far from here. The Christ is named Jesus: he had twelve friends - and one of them was most unreliable. I draw no comparisons from these references, please understand; but I do draw hope. Let us get up and do something in our own shameful mess of a world. It is better than to make excuses; better than to sit on your tenure for thirty years, and hang your hat on a pension.

Note 1

The commercial service that provides consultation and implementation for syntegeation is provided by Team Syntegrity Inc, 34 Palmerston Square, Toronto, Ontario, Canada M6G 2S7

Note 2

The Action Plan put forward in the last section has been devised in collaboration with the World Service Authority, headed by the pioneer world citizen, Garry Davis. For anyone who does not know the story of this brilliant, farsighted and courageous man, his most recent book (Reference 15) is compelling reading. The Year of the Launch, 1993, is the forty-fifth anniversary of his declaration of world citizenship, and his friends will celebrate his birthday during Launch Week.

REFERENCES

1. Beer, Stafford, **The Heart of Enterprise**. Chichester: John Wiley & Sons, 1979.
2. Beer, Stafford, **Diagnosing the System for Organizations**. Chichester: John Wiley & Sons, 1985.
3. Beer, Stafford, **Brain of the Firm**, (2nd edition). Chichester: John Wiley & Sons, 1981.
4. Maturana, Humberto, and Varela, Francisco, **Autopoiesis and Cognition**. Riedel Publishing, Boston Studies in the Philosophy of Science # 42, 1980.
5. Beer, Stafford, **Platform for Change**. Chichester, John Wiley & Sons, 1975.
6. Beer, Stafford, 'I am the Emperor and I Want Dumplings' in **Systems Practice**, Vol.2, No.3, 1989.
7. Beer, Stafford, 'The Will of the People' in **Journal of the Operational Research Society**, Vol.34, No.8, 1983.
8. Hardin, Hershel, **The New Bureaucracy: Wast and Folly in the Private Sector**. Toronto: McClelland and Stewart, 1991.
9. Beer, Stafford, 'On Suicidal Rabbits' in **Systems Practice**, Vol.3, No.2, April 1990.
10. Fuller, R. Buckminster, **Cosmography New York**, McMillan, 1992.
11. Jalali, Assad, 'Association Schemes with Opposition', Research Report, European Business Management School, University of Wales, Swansea, 1993.
12. Beer, Stafford, **Beyond Dispute: the Invention of Team Syntegrity**, Chichester: John Wiley & Sons, in preparation.
13. Beer, Stafford 'The aborting corporate plan', Jantch, Erich, Ed., **Perspectives of Planning**, OECD, 1969.
14. Beer, Stafford, 'Holism and the Frou-Frou Slander' *Kybernetes* Vol. 17, No.1, 1988.
15. Davis, Garry, **Passport to Freedom**, Washington, D.C. Seven Locks Press, 1992.