



CANDLEMAKING

Introduction

This technical brief contains the essential information required to begin the small-scale production of both functional and decorative candles. Candles have been made since the earliest times and they are still commonly made by well established methods requiring only simple equipment. This brief describes how a candle works, and specifies the materials needed for making candles. Four common production methods are also explained with ideas for decorative variations.

How a candle works

A candle is a very simple product which in its simplest form is made up of a central string, (known as the wick) which is surrounded by a fuel source that nowadays is almost always a type of wax. When the wick is lit the heat of the flame melts the surrounding fuel (wax) into a liquid pool which is absorbed by the wick. The heat produced causes the liquid wax to vaporise and this vapour becomes the fuel for the burning flame. In a well designed candle the wick and the wax will burn off at a slow and uniform rate to provide a steady flame and dripping will not occur.

Candlemaking materials

Waxes (the fuel for the candle)

Historically candles were made from animal fats such as beef, sheep and whale fat, but today cleaner and more efficient waxes are used. Most modern candles are made predominantly from paraffin wax which is usually mixed with a small proportion of other wax such as stearine.

Paraffin wax

Paraffin wax is the most important raw material used in candlemaking. It is available in most countries in solid slabs or as pellets or flakes. It is usually white in appearance but goes clear when liquid. It is odourless, tasteless and firm to the touch. Paraffin waxes are supplied with various melting-points ranging from 46° to 68°C. Those waxes which melt at around 58°C are ideal for candlemaking in temperate climates, although wax with a higher melting point is required for use in hotter climates.

Stearine

Stearine is a component of many animal and vegetable fats and has become an important material in candle making. It is important as a hardening agent for paraffin wax owing to its good temperature stability. It helps to overcome the problem of 'bending' which is sometimes experienced with paraffin wax candles in hotter climates. Stearine also helps in the release of candles from moulds, and improves burning qualities. It is commonly supplied as white flakes or granules. Stearine is usually added to paraffin wax in quantities of about 10% but this can be increased to achieve quality improvements. Candles can be made from 100% stearine.

Beeswax

Beeswax is a very highly regarded candle making material. It is excellent for making dipped and poured candles which are usually marketed as a premium product. The wax burns slowly and tends to give off a pleasant natural aroma. Beeswax is obtained by melting the honeycomb of the bee in hot water, straining it and allowing it to cool. At this stage it is a brownish-yellow colour but it can be lightened by bleaching. The wax has a melting point of about 64°C, and is a relatively soft and sticky substance with means that it is difficult to

mould in rigid moulds. Beeswax can be mixed with paraffin wax in quantities of about 5% to improve both the burning time and appearance of the candles.

Vegetable waxes

Many plants, shrubs and trees yield waxes which can be extracted and processed for use in the manufacture of candles. In some cases it may be possible to use these waxes as the main source of fuel for the candle; in others it may only be possible to use them in small quantities to improve the qualities of another wax. Some vegetable waxes (such as soya) are marketed as sustainable and healthy alternatives to paraffin wax because they are derived from renewable sources and often burn more cleanly than paraffin wax.

Other waxes and additives

A variety of specialist waxes and additives are available from specialist candlemaking suppliers but none of these are essential to begin with. They include:

- Dip and carve wax which is soft enough to carve and model at low temperatures.
- Microcrystalline waxes which can be added to paraffin wax to reduce or increase hardness.
- Overdipping wax which gives a high gloss coating to a candle.

Wick

The wick is a very important component of a candle and should be selected with care. Most modern wick is made from braided cotton strands (not cotton thread). A flat braid is adequate for most candles but square and round braided wick is also produced. Some wicks also include a paper or wire stiffener which helps when making container candles (lead core wicks should be avoided). In countries with established candlemaking industries, wicks may be obtained directly from wholesalers or craft suppliers. It is also possible to make wicks by hand if necessary. When the wick is lit, the flame should radiate sufficient heat to melt a small pool of wax at the top of the candle. The liquid wax is then drawn up towards the flame by capillary action where it vaporises and is burnt. When lit, a correctly proportioned wick will curl into the hottest (outer) part of the flame and burn away at its tip, to give a clean bright flame (figure 1).

The basic principle in selecting a wick is: the larger diameter the candle, the thicker the wick. If the wick used is too thick, a large flame will melt the wax too fast and cause dripping on the outer edge of the candle. Conversely, if the wick used is too thin, the flame will be unable to generate enough heat to vapourise sufficient wax and will probably 'drown' in its own wax pool. Substances such as beeswax which are viscous when liquid require a thicker wick than substances with a lower viscosity. In general, the more viscous the liquid fuel, the thicker the wick required. Some trial and error testing is usually necessary.

Figure 1: Wicks

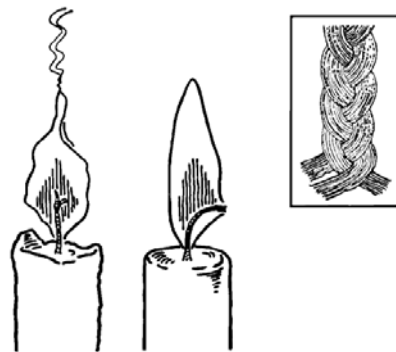

Dyes and scents

Where candles are being sold as decorative items rather than as a source of light, colour and scent can be used to increase the attractiveness of the product.

Candle **dyes** are available in solid blocks or as powder which can be directly added to the wax as it is melting. A wide range of colours are available and suppliers will provide information concerning quantities required, as this will vary depending upon the concentration of the dyes. It is advisable to mix small test samples of colour before

producing candles, particularly since some colours tend to change as they cool. Some dyed candles will have a tendency to fade over time, especially if left in strong light.

Scented candles are now a well established and popular product. Some countries have suppliers offering scents specifically designed for candles. These are liquids that are added to the melted wax during production. The result is a scented candle which usually releases more fragrance when it is lit. The degree to which the scent is released from the wax is known as the 'throw'. Essential oils can also be used as scents for candles and other locally available natural fragrances can be experimented with.

Heating methods

Safety

When heating wax it is very important to be aware of some essential safety precautions. It is important that wax is not overheated. At high temperatures (usually above about 150°C) wax will start to smoke and give off unpleasant and dangerous fumes. At a higher temperature wax will reach its 'flash point' and can spontaneously ignite. An open flame will also ignite liquid wax. Once burning, liquid wax is difficult to extinguish and can cause a serious fire. If a fire does start, the heat source should be turned off immediately and if possible the burning wax should be starved of air (oxygen) by covering with a metal lid or a damp cloth. On no account try to extinguish burning wax with water as it will intensify the fire.

The chances of overheating can be greatly reduced if the wax melting pot is not heated directly. To do this, the melting pot can be placed into a larger container of hot water and the wax heated by the surrounding water. This is known as a double boiler (figure 2). Even with this method, always make sure that the water does not boil away.

Figure 2:
Double boiler

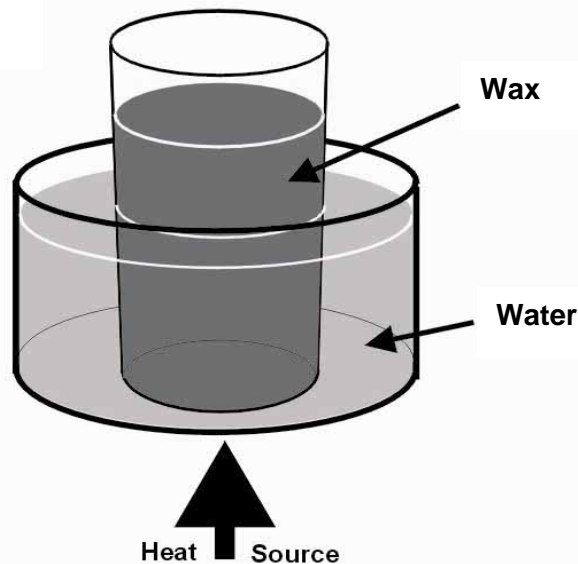

Electricity

Electricity is ideal as a source of heat if it is available, as it is easily controlled. A domestic cooker can be used or heating elements may be attached to the bottom of a suitably sized tank. Electrically heated water jackets may also be used.

Gas

Tanks or pots may be heated on gas burners such as domestic gas cookers. The use of a water bath (double boiler) is safest. If heating a container of wax directly, make sure that the

container has a thick bottom to prevent the wax from burning and take precautions against hot wax coming into contact with the gas flame. The use of a gas heated water jacket may also be considered.

Solid fuel

Solid fuel should only be used where no other source of fuel is available. Great care must be taken to prevent wax from being spilt onto an open fire.

Containers for heating wax

Containers made of aluminium or stainless steel are ideal as they will not rust. However steel or iron can also be used (except in the case of beeswax, where iron equipment is not suitable). Copper and brass should be avoided as they cause oxidation. Large cooking pots are ideal as a first option, but purpose designed containers can be made by metalworkers as the need arises.

Methods of measuring and controlling temperature

It is possible to start making candles without any means of measuring the temperature of the wax, but to make candles efficiently a thermometer or better still thermostatically controlled heater is required. A cooking thermometer (otherwise known as a 'jam or 'sugar' thermometer) is ideal as it will measure temperatures well above that of boiling water. It is important that a thermometer is not heated beyond its upper limit as this is likely to make it very inaccurate in the future.

If it is available, a thermostat is a very good way of controlling the temperature of the wax, provided that it has been accurately calibrated. The use of a thermostat in conjunction with some form of electrical heating equipment allows the wax to be heated to a specified temperature and maintained at that temperature without the need for frequent manual checking and adjustment.

Methods of production

There are four basic methods of candlemaking (each described below) which are particularly suitable for small-scale manufacture:

- Dipping
- Pouring
- Moulding (or casting)
- Container candles.

Dipping

Dipping is the simplest method of making candles. It can be used to make a small number of candles by hand, with very simple equipment, or as a production process for manufacturing large numbers of candles in a variety of sizes and colours.

Method

Heat the wax in the dipping container to the required temperature. The temperature will vary with the type of wax used, but 70°C is a good starting point (eg. for 90% paraffin wax to 10% stearine).

The appropriate thickness wick is then selected and lowered into the wax for the first time. For the first dip only, the wicks should be left to soak in the wax for about two minutes to allow air and moisture to escape. This process is known as **priming the wicks** and should be done with all new wicks. The primed wicks can be drawn through the fingers as they cool, so that any lumps are removed. This will help to ensure that the finished candles are smooth and uniform. Once the wicks are primed the **continual dipping process** can begin. The wicks are repeatedly dipped into the hot wax for about 3-4 seconds at a time. They must be allowed to cool slightly between each dip (for between 1 and 4 minutes, depending upon

room temperature). Each time the wicks are dipped another layer of wax is built up and the candles begin to take shape. In order to obtain a well-formed candle, the wick should be submerged and withdrawn as smoothly as possible to achieve even layers with no drips or other surface imperfections. The length of the candles will result from the depth to which they are dipped and their thickness will be determined by the number of times they are dipped.

The temperature of the liquid wax is important and should be frequently measured; if the liquid wax gets too hot it will melt off more wax from the candles than it adds. On the other hand, if the liquid wax is allowed to get too cool a fine skin will form on the top of the wax and interfere with the clean dipping process. The rate at which the candles grow depends upon three things; the temperature of the wax, the room temperature and the time allowed between dips. When the required thickness has been achieved, the candles are removed, trimmed at their lower ends and allowed to cool.

Figure 3: Hand dipping

1. Priming wicks
2. Dipping to build candle thickness
3. Final dipping
4. Hanging to cool

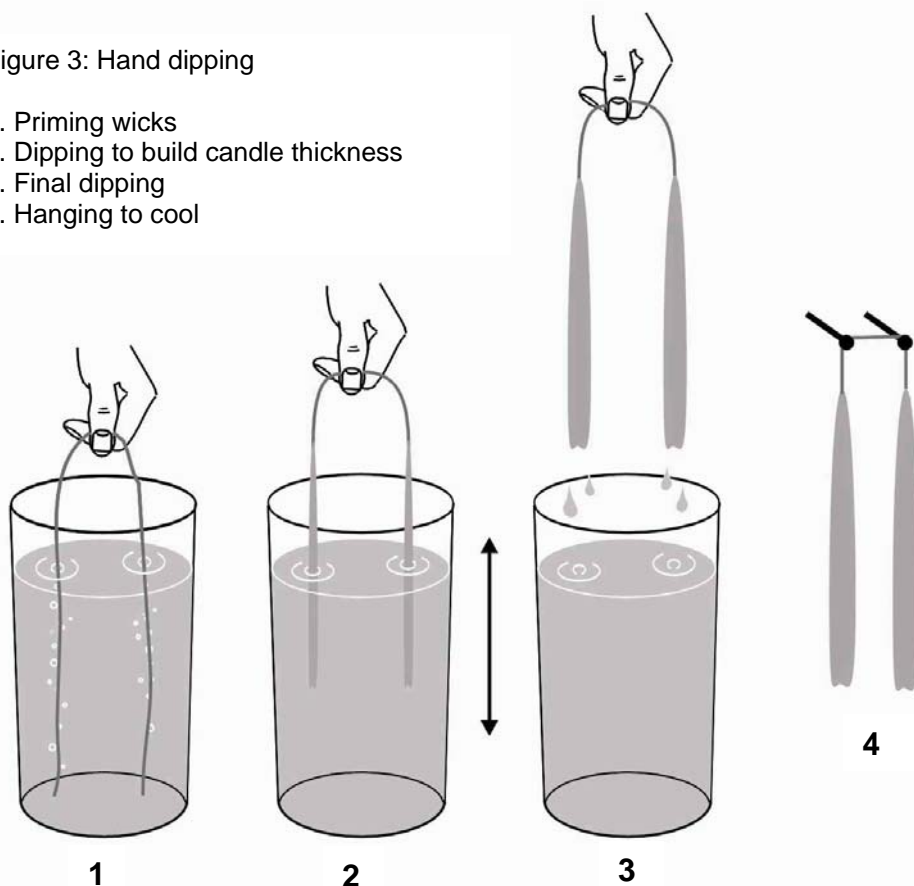

Colours and effects

Dipped candles can be made from pre-coloured wax which will give them a solid colour throughout their thickness. Alternatively they can be made in white wax and then given a final dip in coloured wax which will produce a coloured 'outer skin'. This is known as 'overdipping'.

After the final dip and while the candles are still warm they can be experimented with to produce a variety of decorative shapes. They can for example be rolled flat and twisted or shaped into curves or twisted together before being allowed to cool completely. Alternatively warm candles may be rolled on a flat warm glass, metal, or stone surface for a very smooth surface finish.

Equipment

At the simplest level, dipping may be carried out by holding the centre of a wick and dipping it repeatedly by hand so that a pair of candles is produced (figure 3). Although this will result in a low production rate, it is the principle on which all dipping equipment is based. In larger scale production, a large number of wicks are suspended from a frame and dipped in turn.

Figure 4 illustrates a continuous dipping process for four or more wick holders suspended from a wheel. Using this method, the wheel is rotated after each dip to enable a fresh set of wicks to be presented for dipping.

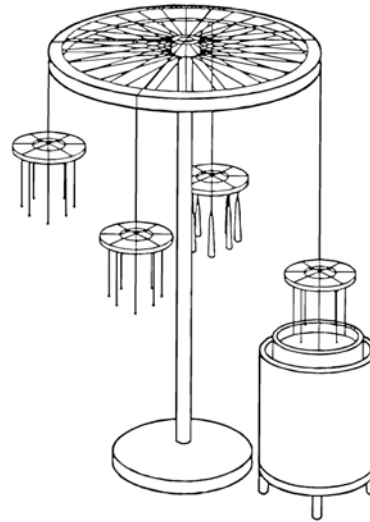

Figure 4: Dipping equipment

Pouring

Pouring candles is very simple and similar in principle to dipping, as it is also a process which builds up candles layer by layer. However pouring is slower than dipping as only one wick can be poured onto at a time. For this reason it is normally only used for very small scale production where a minimum of equipment is available.

Method

Figure 5: Hand pouring

1. Priming wicks
2. Pouring wax onto wick
3. Building candle thickness
4. Hanging to cool

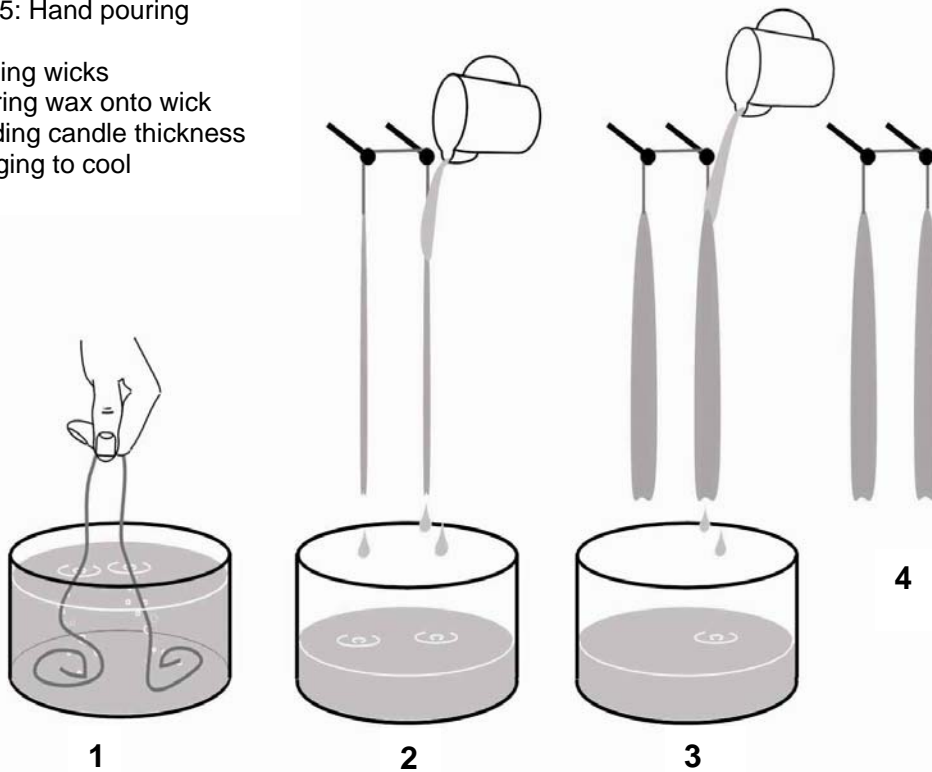

Wicks are primed (see section on dipping) and suspended. Wax is heated to the correct temperature (about 70°C depending upon wax mix) and is poured down each wick in turn, using a jug or ladle. A container is positioned under the wick to catch any wax which drips

from the wicks, and this is re-heated. During pouring, the wick should be twisted slowly to aid the formation of an even coating of wax. It is only possible for a certain amount of wax to be added at each pouring. The candle must therefore be built up from many thin layers; the process being repeated until the required thickness has been achieved. It is important that the conditions are right for pouring: if the candles are too warm and the wax is also too hot, one pouring will tend to melt the previous layer. The temperature of the wax should therefore be adjusted to take into account the speed of working, the workshop temperature and the composition of the wax mixture. During the pouring, the candles may sway a little and stick together. If this happens they can be separated gently with a knife, or by tapping. When a sufficient thickness of wax has been built up, the candles are removed.

Colours and Effects

While candles are still warm they can be shaped and rolled in the same way as dipped candles (see previous section). They can be poured using solid colour or given a coloured finishing coat. Creative decorative effects are possible by experimenting with pouring multiple colours over finished candles.

Equipment The equipment used in the pouring process is very simple (see figure 6). It consists of an old bicycle wheel in a horizontal plane supported by a vertical shaft, the length of which is determined by a suitable working position. The bottom end of the shaft should be located in a heavy base-plate, to ensure that the apparatus is safe for working. The wheel must be able to rotate freely. Small metal hooks made from thin wire are fixed to the outer rim of the wheel, from which the candle wicks are suspended. The wicks are weighted at their lower ends. A heated container, similar to that used for dipping, is positioned so that the outer rim of the wheel is above the centre of the container. A small ladle or jug is required for pouring the heated wax over the wick. After each pouring, the wheel is turned until the next wick is positioned above the wax container and the process is repeated until all the candles are of the required thickness.

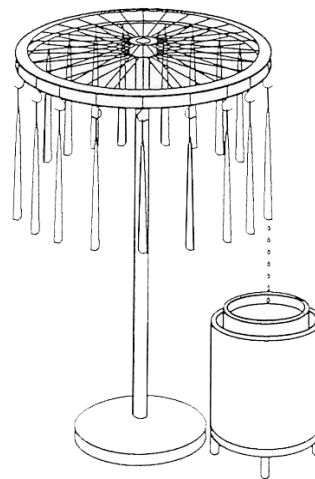

Figure 6: Pouring equipment

Moulding

Candle moulding (or casting) is a method commonly used to make decorative and unusually shaped candles. Each candle produced will need time to cool in its mould, and this can be a limiting factor for large volume production, unless a large number of moulds are acquired.

Method

A blend of wax suitable for moulding is required. The ideal wax will be a hard paraffin wax (with a melting point of about 60°C to 68°C). This is less likely to stick to the sides of the mould than a softer lower melting point wax. A relatively high proportion of stearic acid may be added to improve both the hardness of the candle and its shrinkage when cooling; thus aiding the removal of the candle from the mould.

While the wax is melting the mould can be prepared. A suitable thickness wick should be primed (see section on dipping) and threaded through the hole in the mould (there is usually a hole in the bottom of the mould for this purpose). Seal the hole with mould sealant (available from candlemaking suppliers) or an equivalent substance such as clay. Tie the

other end of the wick to a pencil (or equivalent) and ensure the wick is taut and centrally positioned.

When the temperature of the wax is about 90°C use a jug to carefully pour the wax into the centre of the mould. Try to fill the mould at a slow but continuous rate, without splashing or pouring onto the sides of the mould. After a minute or two give the mould a sharp tap to dislodge any trapped air. Now the candle can be left to harden or placed in a water bowl to accelerate the cooling process. As the wax cools it contracts and shrink cavities will appear. These cavities should be opened with a sharp knife to allow filling with more liquid wax. Do not fill beyond the original wax level. Do not try to remove the candle from the mould until you are sure that it is fully hardened.

To de-mould the candle, remove the sealant and whilst gripping the wick at the bottom of the candle, pull the candle from the mould. The candle should pull out of the mould easily, however if it is sticking it can be placed in a refrigerator or cold water for a short period of sudden shrinkage. If there is still a problem with de-moulding, the candle can be melted out with hot water, but this will probably spoil the surface finish.

Figure 7: Moulding candles

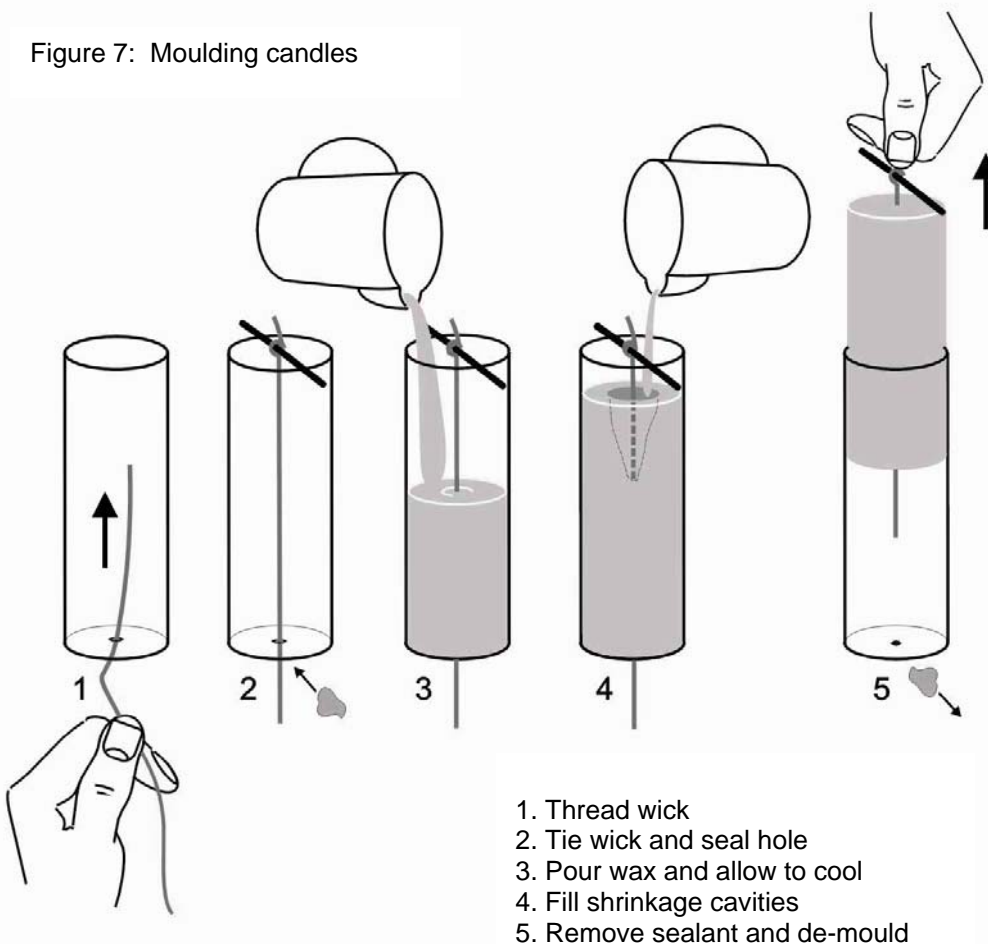

Equipment

In general, candle moulds come in two varieties; rigid and flexible. Rigid moulds are made from materials such as metal, glass, and plastic whereas flexible moulds are made from rubber or PVC. Flexible moulds can be used to produce irregular-shaped candles and also allow undercuts. Moulds are available for purchase in a wide range of shapes and sizes, but they can also be designed and handmade by the candlemaker. Remember that the candle will be an exact replica of the internal shape and texture of the mould.

Colours and effects

Candles can be moulded in any colour or can be poured in several different coloured layers to make horizontally striped candles. Experimenting with tilting the mould between multi-coloured layers can produce angled striped effects. Other ideas can be explored such as filling the mould with chunks of solid wax and then filling with liquid wax, or by adding small amounts of solid dye before the wax has hardened. Candles with multiple wicks and a variety of scents are also options.

Container candles

Container candles (also known as votive candles) are small candles set in a heat-proof container. They are extremely simple to produce and are popular as decorative items and are usually sold as fragranced candles. In their most basic form they are made from a heat resistant container filled with wax with a central wick.

Method

Choosing appropriate containers for the production of container candles is important. The container must be safe, even when the candle has been burning for a long period. Heat resistant materials such as metal tins, ceramics and glass are ideal, although care must be taken with glass as it sometimes has a tendency to crack or shatter when heated. The selection of wax is also important, as it should be a type of wax that burns slowly and that has low shrinkage. If the wax shrinks too much it will not stay in place in the container and may form ugly sinkholes around the wick as it cools. Most natural waxes are ideal for container candles, and beeswax is perfect.

While the wax is melting, prime a wick that is slightly longer than the depth of the container and attach a small weight to the bottom of the wick (purpose made metal wick sustainers are ideal). If scent and colour are required add them to the liquid wax and stir. Carefully pour the liquid wax into the container to the desired level and then place the wick into position using a long needle or stick to suspend it. Allow the wax to cool slowly and trim the wick.

Figure 8: Container candles

1. Prepare and prime wick
2. Position wick centrally in container
3. Pour wax
4. Allow to cool and trim wick

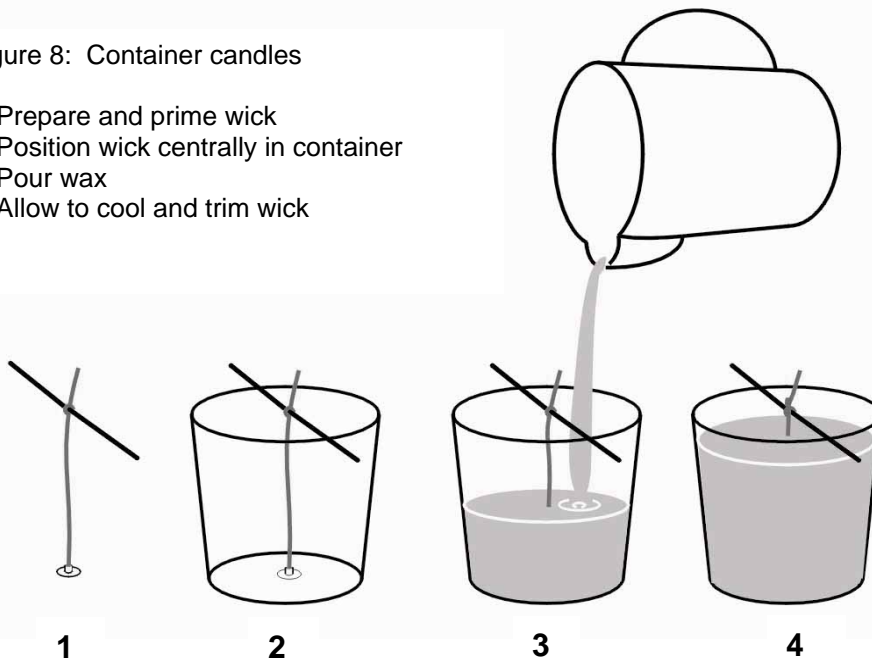

Colours and scents

The appeal of a container candles is usually a combination of visual beauty and aromatic fragrance. Use colours that compliment the scents and try adding embedded decoration such as flowers or petals.

References and further reading

Books

There is a large selection of books available which explain the common methods of candlemaking. Most are designed for use by people making candles as a hobby, but some are more advanced and also cover candlemaking as a small enterprise. Some books deal with one method only such as dipping, or using beeswax.

Beginners Guide to Candlemaking by David Constable, Search Press 2002 ISBN 0 85532832 0

Candlemaking: Creative Designs and Techniques by David Constable, Search Press 2002 ISBN 0 85532683-2

Traditional Candlemaking: Simple Methods of Manufacturing by Deborah Millington, IT Publications, 1993 ISBN 1- 85339-124-7

The Candlemaker's Companion: A Comprehensive Guide to Rolling, Pouring, Dipping, and Decorating Your Own Candles by [Betty Oppenheimer](#) (Paperback)

Website resources

Completely independent information resources are rare on the internet. Most information sites are sponsored by advertisers. However some also offer good information, articles and forums. Some are also suppliers of materials and equipment.

<http://www.candlemaking.org.uk/>

<http://www.candlecauldron.com/>

<http://www.candlemakingsupplies.co.uk>

<http://candles.articlebee.net/>

Useful resources for candlemaking with beeswax

<http://www.thorne.co.uk/>

<http://www.reigate.demon.co.uk/candles.htm>

Information about soya wax and candlemaking with soya

<http://www.soya.be/soy-candles.php>

This Technical Brief has been edited in March 2008 by Rob Aley, Specialist Candlemaker at <http://www.thewaxstudio.com/> and small enterprise development advisor.