

\$3.50 U.S.  
\$4.95 CAN.

# HOME POWER

THE HANDS-ON JOURNAL OF HOME-MADE POWER

ISSUE # 22

APRIL / MAY 1991







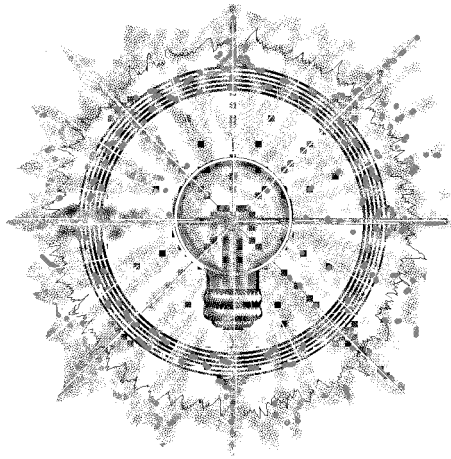





























REAL  
GOODS  
FULL  
PAGE



# HOME POWER

## THE HANDS-ON JOURNAL OF HOME-MADE POWER

### Contents

-  **From us to YOU– 4**  
Is this an Energy Policy?
-  **From us to YOU– 4**  
Crew & Credits & Legal Smütz
-  **Systems– 6**  
Huckleberry Homestead
-  **Conservation– 11**  
Energy Conservation in the City
-  **Wind Power– 15**  
A Primer on Wind Generators
-  **Things that Work!– 22**  
PowerStar's UPG1300 Inverter
-  **Hydrogen– 26**  
The Schatz PV/Hydrogen Project
-  **Hydrogen– 32**  
Hydrogen Fuel
-  **Why Use RE?– 35**  
RE Offers Freedom
-  **Domestic Hot Water– 38**  
Gettin' into Hot Water
-  **PV Structures– 41**  
Rack Hacking
-  **Efficient Appliances– 44**  
Washing Machine Conversions
-  **Subscription Forms– 51**  
Subscribe to Home Power!
-  **Things that Work!– 53**  
Trade Wind's Wind Odometer
-  **Things that Work!– 55**  
SunAmp's Bar Graph Voltmeter
-  **Tech Notes– 57**  
Trace's new wiring box
-  **The Basics– 59**  
System Design
-  **Code Corner– 68**  
Load Circuits
-  **Things we can live without– 70**  
Plug it in, plug it in...
-  **Home & Heart– 71**  
Marginally Mountain
-  **Homebrew– 73**  
Hacking the Renavair Panel
-  **Energy Fairs– 75**  
Fairs Everywhere!
-  **Happenings– 79**  
Renewable Energy Events
-  **Good Books– 81**  
Renewable Energy Reading
-  **the Wizard Speaks– 83**  
of Cardinality and Cantor
-  **Writing for Home Power– 83**  
Share your info!
-  **Letters to Home Power– 84**  
Feedback from HP Readers
-  **Q&A– 91**  
A manner of techie gore
-  **Ozonal Notes– 94**  
Our Staph gets to rant & rave...
-  **Home Power's Business– 95**  
Advertising and Sub data
-  **Home Power MicroAds– 96**  
Unclassified Advertising
-  **Home Power Mercantile– 98**  
Advertising and other stuff
-  **Index to HP Advertisers– 98**  
For All Display Advertisers

### Access

Home Power Magazine  
POB 130  
Hornbrook, CA 96044-0130  
916-475-3179

### Think About It

"Never doubt that a small group of thoughtful committed citizens can change the world: indeed, it's the only thing that ever has."

Margaret Mead.

### Cover

Walt and RaQuel Stillman on their Huckleberry Homestead. Sunshine makes their electricity and heats their water. Story on page 6.

Photo by Rebecca Golly.

## Bush's Energy Non-Policy for the Suicidal and Terminally Stupid

Bush's new energy policy assumes we are fools with a death-wish. There is nothing new in drilling Alaska till it hurts or in building more nuclear power plants. This is the same short-sighted BS that has gotten us in environmental trouble and into war. Let's look at the facts.

### Sucking Alaska Dry

There really isn't that much oil in Alaska. How much? Well, look at it this way. Alaska contains less oil than we'd have saved by sticking with the EPA automobile mileage guidelines modified in 1980s. When the government lessened these EPA requirements, auto makers stopped making more efficient vehicles. This one dumb move has consumed more than all the oil in Alaska. Drilling Alaska only postpones the inevitable, destroys Alaska, and pollutes us all in the process. We need alternatives to oil burning, not more oil.

### More Nukes

No one is building new nuclear power plants. Nukes under construction are being decommissioned. The reasons for this are simple:

**One**, no one knows what to do with the radioactive leftovers.

**Two**, the nukes operating now are more expensive and have more down-time than any other type of power plant.

**Three**, when the Washington Public Power System (WPPS) failed financially, it took the entire nuclear power industry with it.

The third reason is what has really stopped nuclear power. The WPPS bonds (AAA rated municipals) went from valuable to worthless in a single day. No one will finance new nukes because they are financial disasters. Let us give thanks for small favors because if nukes were cost-effective, then we'd have to deal with their radioactive waste. And no one has the answer to that.

### Something Else?

Yes, we want something else! We're tired of the same old dreck that is visibly poisoning our planet and picking our pockets. We're ready to do whatever it takes to give this planet a sustainable energy future. And here's what it takes

### Use Renewable Power Sources

Make power from sunshine, wind and falling water. There are between 30,000 and 50,000 households now doing this in America. Home power producers have their own power company. No monthly bills, no black outs, and no pollution.

### Conserve Electricity

If you can't get your power from a renewable source, then conserve every watt-hour. Use efficient appliances. Turn off appliances when not in use. Be aware that the cost of grid power is much higher than your electric meter shows. Treat every watt like it will come back and bite you- because it will. Coal, nuclear, and oil power plants all extract a high price from our environment.

### Drive Clean

Keep your vehicle in top shape. Drive only when necessary. Drive slowly. Keep your tires pumped up. Use an electric vehicle. Demand automakers produce emission-free vehicles. Then buy one and smile as you drive it.

### A Green Dream

Green certainly, but this is no dream. Look at the articles in this issue alone. These are people who are living the Green Dream. Check out Huckleberry Homestead on page 6, they're doing it. Check out the electric car on page 85, they're doing it. If we just plain ole' regular folks can accomplish this on our budgets, then government and big business has no excuse.

It's a dream until you decide to live it...

*Richard, Karen, Kathleen, Stan, Bob-O, the Wiz & the HP Crew.*

## People

Bill Battagin  
Michael Bergey  
Sam Coleman  
John Drake  
Jim Forgette  
Rebecca Golly  
Betty Gulden  
Tim Gulden  
Kathleen Jarschke-Schultze  
Stan Krute  
Karen Perez  
Richard Perez  
U.R. Riptoff  
Mick Sagrillo  
Bob-O Schultze  
L.E. Spicer  
RaQuel Stillman  
Walter Stillman  
John Wiles

## Printing

RAM Offset, White City, Oregon  
Cover 50% recycled (40% pre-consumer, 10% post-consumer), low chlorine paper. Interior is recyclable, low chlorine paper. Soybean ink used throughout.

## Legal

Copyright ©1991 Home Power, Inc. All rights reserved. Contents may not be reprinted or otherwise reproduced without written permission.

Home Power Magazine (ISSN1050-2416) is published bi-monthly for \$10 year at POB 130, Hornbrook, CA 96044-0130. Application to mail at second class postage rates is Pending at Hornbrook CA. Postmaster send address corrections to POB 130, Hornbrook, CA 96044-0130.

While Home Power Magazine strives for clarity and accuracy, we assume no responsibility or liability for the usage of this information.

Canada post international publications mail (Canadian distribution) Sales agreement #546259.



SOLAREX  
FULL  
PAGE  
AD



Above: Huckleberry Homestead is owner-built and solar powered. Photovoltaics make the electricity and a solar thermal collector makes the hot water. Photo by Rebecca Golly.

# Huckleberry Homestead

Walter Stillman

©1991 Walter Stillman

**T**he decision to use solar electricity was partly due to the quarter mile between the building site and the public utility. A wide swath would need to be cut through a heavily forested area to bring power lines to the house. The choice became obvious shortly after the California public hearings on offshore oil drilling.

## The Ocean Blue

Our house is a simple two room, two story box shaped structure situated just east of a Pacific coastal ridge in a third growth conifer forest. Solar energy is collected as electricity and hot water.

After a great day of fishing off the rocks, my wife, RaQuel, and I were discussing the inevitable despoiling of the shore, when she suggested that we attend the hearing in

Fort Bragg to show our support for those opposing the oil lease sales.

On the day of the hearing the hall was packed and thousands of people gathered outside. Everyone was allowed to comment on the proposed lease. Day passed to night with no end in sight to the number of people waiting to speak. Among them were artists and townfolk, fishermen and surfers, marine biologists and

Native American leaders. Some spoke of the environmental damage drilling would cause, and of our senseless addiction to oil. Others spoke eloquently and affectionately of clean air and water, of abalone, starfish, and sand crabs. All were opposed to the oil lease sales.

I listened to the radio broadcast of the testimony late into the night. I could sense the energy and optimism of the crowd growing with each speaker. Could it be that the voice of an individual can be heard over the clatter of the machinery that powers big business and government? Heartened, I vowed to take steps toward assuming a greater responsibility for our energy use.

### The Power To Build

Construction began two years ago with a foundation and a battery shack. The shack houses sixteen Trojan L-16 lead acid batteries and our control panel. Eight Arco M-75 PV panels covered the roof. This supplied the power for the Skil saw, table saw, etc., for construction. After completion of the basic outer shell we moved in and put the panels on the roof of the house. We've lived with the system for a full year now and feel comfortable and confident with it.

The control panel was assembled by Earthlab of Willits, CA and consists of the following components:

- Photron 30 amp. charge controller

- Trace 2024 2000 watt inverter with these options: turbo, stacking, low voltage cut off, & charger.

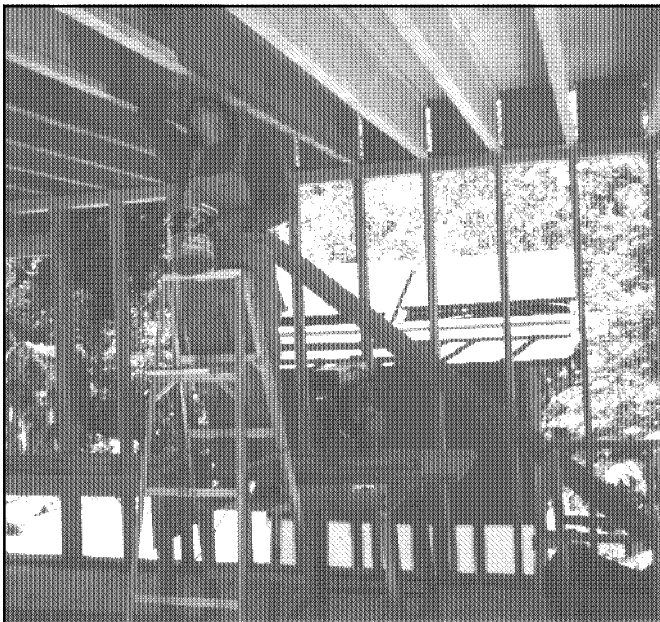

Above: RaQuel Stillman hard at work on her owner built home. Note the PV panels on the shed outside.

- DC fuse box

- AC fuse box

- Fuse and disconnect switch for PV array.

- Fuse and disconnect switch for all loads.

- Meter box with three meters; voltage, amperage from array, load amperage.

- Switch box for using a back up generator.

This last feature uses the inverter as a battery charger and has yet to be used for several reasons. First, our generator doesn't run and is waiting for my attention. Second, the battery bank is large enough at 1,400 ampere hours at 24 volts that the system can hold out through extended winter storms. Third, we conserve a bit extra during the winter months. Mainly by avoiding use of the electric coffee maker and watching our use of lights a little more carefully. The large battery bank results in more of a seasonal fluctuation in voltage than simply a daily one. Voltage in winter typically hovers around 25 to 27 VDC. In the summertime it's usually 28 to 30 VDC.

As long as our average monthly consumption of power is less than the monthly average production, we stay ahead. This allows the impact of the occasional day of construction work with power tools to be absorbed and balanced by days of relatively low power use.

Power tools, such as the table saw, are never left to run continuously, but are shut off between cuts. I rarely measure and mark more than one piece to be cut at a time. I work slowly which helps to spread the power use over time. Projects that require extensive use of my power sander I take to a neighboring cabin that has public utility electricity. There RaQuel or I sometimes sand continuously for hours.

### 24 Volts

The decision to use 24 volts as opposed to 12 volts was made mainly because of the stacking option of the Trace 24 volt inverter. This allows the possibility of adding a second inverter to double the AC wattage capacity. This seems highly unnecessary after a year and a half of use. Two thousand watts runs virtually any single tool or appliance. It probably would run the toaster and coffee maker at the same time. Would it be necessary to run the table saw while we make breakfast? So far it has never been a limitation.

The advantage of having 24 volts seems to be the longer circuit runs allowable. The disadvantage is the limit of 24 volt appliances available. Particularly a radio and telephone answering machine would be useful, although there are options. Perhaps we can find a device that can

convert 24 to 12 volts at two or so Amps. Another alternative would be to have a split system with a couple of batteries for the 12 Volt system and a special charge controller to evenly charge the bank.

DC uses are lights and refrigeration. Lights consist of eight 40 watt fluorescent units, four upstairs and four downstairs and one 25 watt incandescent. Typically, two to three lights are on for several hours of each evening. It helps to have many light fixtures so you can shed direct light where needed. Refrigeration is a 12 cu. ft. Sunfrost.

AC uses are power tools for continuing construction work, television, VCR, coffee maker, toaster, an outside light, a reading light, and a radio-tape stereo set.

There seems to be a trend by those in the industry steering PV users toward strictly AC. This is a testimony to the reliability of the modern inverter. However, complete reliance on your inverter to power your house doesn't seem sensible. Reliability is one of the features of a home power system. During a recent power failure our neighbors came over for a dinner and a movie.

### Hot Water

Our water supply is a spring fed, gravity delivered, system so no power is needed here. For a water heater we chose a propane AquaStar 80 instant hot water heater because of its solar backup option. At its highest setting, with a low flow shower head to slow the water flowing through the heating coil, the water was just hot enough for a pleasant shower. This sufficed until we were ready to expand our plumbing to the roof and wood stove.

Our solar hot water panel is a well constructed 4' x 8' Heliodyne. The heated water circulates up to a stainless steel 55 gallon tank in the attic, using a thermosyphon. A thermosyphon is a simple physics law that says that cooler water in the lower part of the tank drains to the lower part of the panel (or stove insert, depending on the time of year). The heated water rises out of the top of the panel and on to the top of the tank. This requires the tank to be higher than the panel. We placed our tank on its side in a tight attic space just under the peak of the roof. The panel was mounted to the lower edge of the roof giving us the effect we needed.

In our system the water is drained from the solar panel in winter. A gate valve in each line from the tank to the panel is closed and all plumbing on the roof is drained. To compensate, water circulates through a Holly Hydro wood stove insert that uses the heat of burning wood. The water thermosyphons here also.

If installed properly, this is a perfect complement to solar hot water. I found the tank at an industrial surplus dealer and had four fittings welded to it, two on top and two on the bottom. One at the top tees off to accept the heated water from the solar panel and the wood stove insert. The other fitting, at the bottom, is the cold water inlet. Lastly, one at the top is hot water that goes first through the Aquastar instant hot water heater and then to shower and sinks. A Zomeworks' one way check valve in each cold water thermosyphon line prevents a back flow of hot water into the cold stove insert or the panel at night.

Two pressure-temperature relief valves are used. One is attached to the top of the tank at the hot water outlet for the Holly Hydro according to the manufacturer's instructions. Both vent to the outdoors. An air vent is placed on the incoming thermosyphon fitting on the top of the tank to vent any air bubbles that might enter the system.

The tank is mounted on a large pan with a drain leading outdoors in case of a leak. The attic framing is beefed up in the area of the tank to hold the concentrated weight of roughly 500 pounds.

I installed the wood stove insert in the lower back end of the stove and it heats the water moderately depending on the weather. The colder it is, the more continuously we burn wood and the water gets somewhat hotter. This could have been improved by putting the insert in a hotter location in the stove.

The water from the solar system is so hot that a fair bit of cold water is needed for a comfortable shower. This helps extend the 55 gallons, which has been more than enough for our needs. The tank has been wrapped with fiberglass insulation so the water stays hot through the night and into the next day.

The Aquastar senses the temperature of the incoming water and comes on only enough to heat the water. When the panel is in operation, the flash heater comes on only momentarily until hot water from the tank reaches it. Then it shuts off completely.

### Reconnecting Through Disconnecting

Aside from solar electricity and hot water we derive a lot of pleasure from doing it ourselves. RaQuel and I built the house ourselves with help from family and friends. We used trees cut from the building site to make milled paneling and window frames. Our raised bed garden provides food year round in our climate. Our composting toilet gives us a never ending supply of fertilizer. We



enjoy preserving and canning and gathering fruit from the abandoned homesteads of our area as well as wild food and medicinal herbs. Articles from Home Power have inspired us to build an electric vehicle. We're still gathering information, but it seems natural to make this next step toward energy independence.

We've learned that there are many hidden costs of supplying the public with their energy needs. From environmental impact and the wasteful networks for delivering energy to its users, to the political struggles to control the ownership and distribution of energy for purposes of financial gain and power over others.

These costs are rarely considered by utilities and public officials who compute the bottom line cost of the power.

If the rental house that we lived in before we built our own home is any example, the solar power system needed to cover its roughly 15 kilowatt-hour daily consumption would have cost an astronomical sum compared to the roughly 1.2 kWh daily we now use. The 50 gallon electric water heater alone was responsible for over half of our electric bill.

The difference is that we now assume responsibility for generating our own power. It has become mandatory to have an intimate knowledge of our actual energy needs.

There was a time in our not too distant past that individual families and small communities were required to produce virtually all their needs, food, clothes and shelter themselves. Cultures that remained in place long enough developed an extensive knowledge of the plants, trees, animals, terrain, and weather patterns, essentially the resources of that land. I believe that because of this they had a strong sense of stewardship of the land, of what constituted overuse or abuse and worked to maintain viable resources of their area.

Such things as waters from the river were not seen as simply something to drink and wash with, though they humbly drank and washed. It was a wild and living thing.

It seems the more removed we become from the things that support our life, the more we're

inclined to think we know something by calling it a name and giving it a price tag.

In what we refer to as progress, modern man has sacrificed his intimacy with the land for conveniences and technology. I feel strongly that technology, in the form of such tools as communications, will help bring about a global sense of community. Meanwhile, we could do well to take some of the responsibility and control over our lives back from those who would do it for us.

**Access**

Author: Walt and RaQuel Stillman, POB 536, Pt. Arena, CA 95468



*Walt & RaQuel Stillman's System Costs*

|                                      | Item Cost       | % of Sub Total | % of Grand Total |
|--------------------------------------|-----------------|----------------|------------------|
| <i>System Power Components</i>       |                 |                |                  |
| Earthlab Panel (inc. Trace inverter) | \$3,262         | 36.9%          | 25.9%            |
| 16 @ Trojan L-16 Batteries           | \$2,864         | 32.4%          | 22.7%            |
| 8 @ ARCO M-75 PV Modules             | \$2,320         | 26.3%          | 18.4%            |
| Battery Cables                       | \$237           | 2.7%           | 1.9%             |
| PV Array Cables                      | \$110           | 1.2%           | 0.9%             |
| PV Module Mounts                     | \$45            | 0.5%           | 0.4%             |
| Sub Total                            | \$8,838         |                | 70.2%            |
| <i>24 VDC Powered Appliances</i>     |                 |                |                  |
| 12 cu. Ft. Sunfrost Refrigerator     | \$1,700         | 76.6%          | 13.5%            |
| 8 @ 40 W. Fluorescent Lights         | \$520           | 23.4%          | 4.1%             |
| Sub Total                            | \$2,220         |                | 17.6%            |
| <i>Domestic Hot Water System</i>     |                 |                |                  |
| Heliodyne DHW Panel                  | \$625           | 40.7%          | 5.0%             |
| Aquastar instant water heater        | \$395           | 25.7%          | 3.1%             |
| Assorted fittings, pipe and stuff    | \$150           | 9.8%           | 1.2%             |
| Stainless Holly Hydro insert         | \$135           | 8.8%           | 1.1%             |
| Stainless 55 gallon tank             | \$115           | 7.5%           | 0.9%             |
| Welding                              | \$45            | 2.9%           | 0.4%             |
| Stainless fittings                   | \$40            | 2.6%           | 0.3%             |
| Zomeworks check valves               | \$32            | 2.1%           | 0.3%             |
| Sub Total                            | \$1,537         |                | 12.2%            |
| <b>GRAND TOTAL</b>                   | <b>\$12,595</b> |                |                  |

## SIEMENS

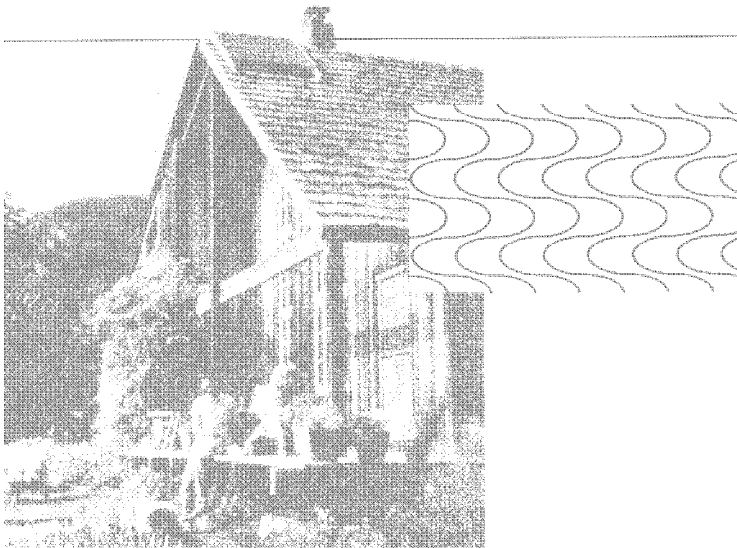

### Home Power with Sun Power

Long after the sun has set, our lights are still on.

Use the sun to provide your own source of electricity to even the most remote homes.

Siemens Solar electric systems power 12-volt appliances; lights, T.V.'s, two-way radios, water pumps, small refrigerators, telephones and more. Siemens solar systems run small a.c. electric tools and equipment with a simple inverter.

#### Siemens Solar Industries

##### WE OFFER:

- Complete line of balance of systems products
- Computerized system sizing
- Installation
- Financing
- Alternate energy products
- Group buy drop shipments

CALL TODAY FOR FREE BROCHURE  
Phone 301-686-2500 FAX 301-686-6221

ATLANTIC SOLAR PRODUCTS, INC.

9351 J PHILADELPHIA ROAD • POST OFFICE BOX 70060  
BALTIMORE, MARYLAND 21237

The Siemens module is the heart of any solar electric power system.

- Rugged and environmentally safe
- Completely quiet
- Engineered for maximum power
- Reliable and low maintenance
- Cost efficient

And all UL Listed solar electric power modules carry Siemens' 10 year warranty.  
The New World Leader in Solar Technology

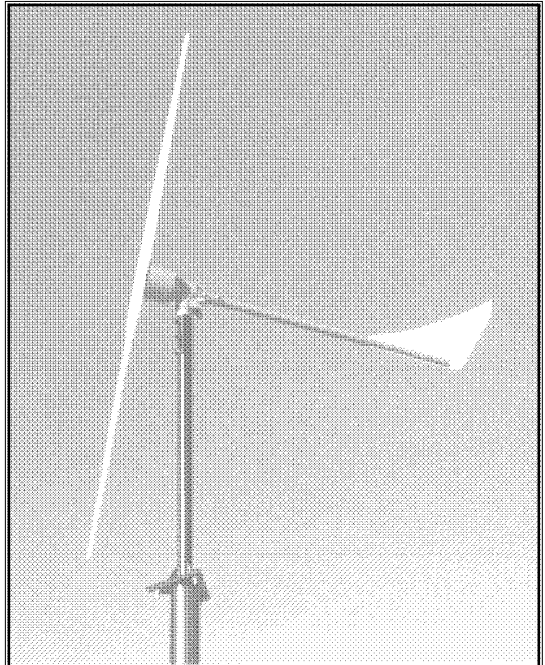

### THE NEW WHISPER 1000

#### 1000 WATT WIND GENERATOR

- \* MAINTENANCE-FREE, ONLY 3 MOVING PARTS
- \* BRUSHLESS, PERMANENT MAGNET ALTERNATOR
- \* UNIQUE, TILT-UP GOVERNING-NO SPRINGS
- \* MODEL 1000 LV CHARGES 12, 24, 32-36, OR 48v BATTERY.
- \* MODEL 1000 HV CHARGES 64-72, 120, OR 124v BATTERY, CAN BE USED FOR HEATING AND WATER PUMPING.
- \* PRICED AT ONLY \$1290, UPS SHIPPABLE

A truly exceptional wind powered generator for new home power systems or for substantial additional capacity in existing photovoltaic systems. New for 1991, key parts are stainless steel for corrosion protection. OUR BROCHURE IS FREE, send for it now!

#### World Power Technologies, Inc.

19 Lake Ave. N. Duluth, MN 55802  
218-722-1492 • Fax 218-727-6888

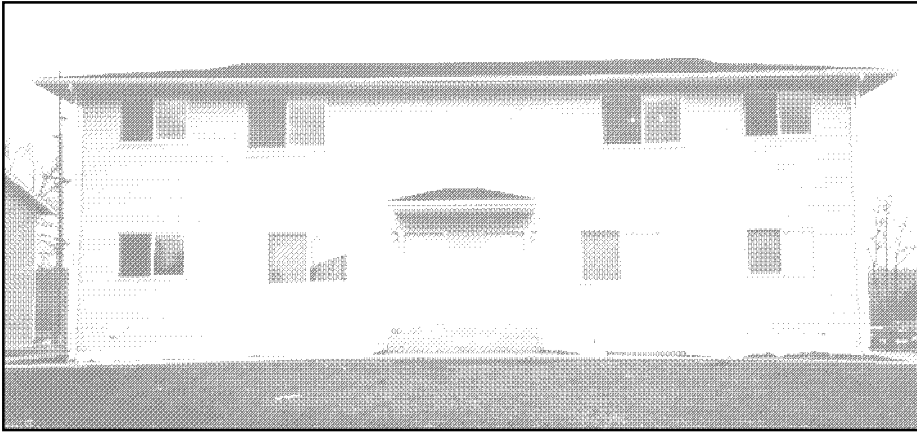

Above: 731 East Front Street, Winona, Minnesota. One apartment in this all electric building got an efficiency job that reduced its power consumption by half! The cost? \$81.52 The savings? Almost \$200 in the last five months and the power savings go on and on and on...

Above: Tim and Betty Gulden. These folks are not only saving money, but also our environment by common sense use of electric power.

# Energy Conservation In The City

Tim and Betty Gulden

©1991 by Tim and Betty Gulden

**E**nergy conservation is important to everyone. Anybody living in the city can conserve energy right now with little or no impact to one's comfort or one's bank account. You will save money and help the environment, too.

## Our Location

October 1, 1990 we moved into a week-old 4 plex apartment building in South Eastern Minnesota. It measures 27' by 27' and occupies 729 square feet of floor space. The apartment was built to current building codes with 6" walls, 6" floor and 22" ceiling insulation, and double pane windows. Three of the four apartments have two people living in them. Apartment 3 has three people. We live in apartment 4. Everything is run by electricity in all our apartments.

We have all the modern conveniences of the typical home. Our major appliances are as follows: frost free 14 cubic foot refrigerator/freezer, electric range, 800 watt microwave, and electric hot water heater.

Our remaining, smaller, appliances are: 19 inch color TV, high powered stereo system, toaster, blender, mixer, can opener, answering machine, cordless phone, computer (with dual disk drives, monitor, and printer), hair dryer, curling iron, two alarm clocks, slot machine, and bathroom/kitchen vent fans.

## Initial Investment

I replaced the six incandescent lamps with six 18 watt compact fluorescent lights for \$61.02. I installed a water saving shower head with on/off valve for \$20.50. It has a maximum measured flow of 1.8 gallons per minute. My total investment is \$81.52, including tax.

## Modifications to our Apartment

I used two accurate thermometers. One to calibrate the four bimetal thermostats that control our electric baseboard heaters. The other to set the refrigerator's temperature at 38°F. We keep the apartment temperature at 70°F. I found that we need only one baseboard heater located on the wall between the living room and bedroom. Enough heat travels thru the bedroom wall and enters thru the bedroom door to maintain 70°. We have experienced no temperature discomfort when the outdoor temperatures dips to -15°F.

Our electric hot water heater is located two stories below us and supplies us with 110 degree water at the faucet. This is plenty hot for all our hot water needs.

## Energy Conservation

### Modifications to our Life Style

The following modifications are so slight that after a few weeks they become routine. They are as follows:

1. Open and close the entry door as quickly as possible. The door is directly exposed to the outside with no air lock. This will limit the amount of cold air entering the apartment.
2. Shut off lights and other appliances when not in use.
3. Close the refrigerator soon after opening. It takes approximately 15 seconds to displace its cold air.
4. Take shorter showers & use an On/Off valve when soaping up.
5. Keep the apartment temperature at 70°F. Monitor with an accurate thermometer.
6. Keep the two South facing window blinds open to take advantage of the Sun's solar heat.

### The Measured Results

I read and record all four electric meters in our apartment building on the 1st and 15th of each month at 11:00 AM. I enter these figures into a spreadsheet program which allows me to graph the results. Each bar on the graph represents a two week period.

### *Electric Power Consumption of Four Apartments 731 East Front St., Winona, Minnesota*

| DATE   | Power Consumption-kilowatt-hours (kWh) |                 |                 |                 |
|--|--|-----------------|-----------------|-----------------|
|  | Apt.1                                  | Apt.2           | Apt.3           | Apt.4           |
| 1 November 90                                | 448                                    | 422             | 513             | 200             |
| 15 November 90                               | 532                                    | 383             | 534             | 243             |
| 1 December 90                                | 547                                    | 473             | 624             | 213             |
| 15 December 90                               | 636                                    | 553             | 609             | 290             |
| 1 January 91                                 | 891                                    | 831             | 854             | 574             |
| 15 January 91                                | 825                                    | 691             | 614             | 423             |
| 1 February 91                                | 1024                                   | 896             | 778             | 555             |
| 15 February 91                               | 663                                    | 470             | 463             | 274             |
| 1 March 91                                   | 681                                    | 509             | 515             | 356             |
| <b>Total kWh</b>                             | <b>6247</b>                            | <b>5228</b>     | <b>5504</b>     | <b>3128</b>     |
| <b>Average kWh<br/>per Month</b>             | <b>1388</b>                            | <b>1162</b>     | <b>1223</b>     | <b>695</b>      |
| <b>Average Power<br/>Bill per Month</b>      | <b>\$113.83</b>                        | <b>\$95.27</b>  | <b>\$100.30</b> | <b>\$57.00</b>  |
| <b>Total Power Cost<br/>4.5 Month Period</b> | <b>\$512.25</b>                        | <b>\$428.70</b> | <b>\$451.33</b> | <b>\$256.50</b> |

The bar graph represents Oct 15, 1990 thru Nov 1, 1990 and so on. The electricity dramatically increased between Dec 15 and Feb 1. During that time the temperature dipped to -15°F. for many days. Our electricity is currently running 8.2 cents per KWH. This includes the basic charge of \$6.50, City fee of 4%, and State tax of 6%.

### Conclusion

Our total electricity cost for the past 18 weeks has been \$256.50. The average electricity cost of the other three apartments for the same time period is \$464.12. The difference is \$207.62 or 2,532 KWHrs. Subtract our initial investment of \$81.52 and we have a net gain, to date, of \$126.10. And we save even more every day...

### Quality of Materials

We are more than satisfied with the shower head. We can vary the spray from a light to a very satisfying, massaging, and forceful spray. To date the spray pattern remains constant with no nozzle clogging. I wish the fluorescent lights were so reliable.

Since our initial purchase, we have returned three of our lights for replacement. I am a little disappointed with the reliability and hope it will dramatically improve in the future. *(Editor's note: Home Power tested the Lights of America models and found that, while they are inexpensive, you get what you pay for. We recommend the OSRAM EL series fluorescents, they cost more, but they work better and they last. RP.)*

### Future Plans

We plan to dramatically cut our air conditioning bills this summer. I will install a 24 hour timer to the wall air conditioner and operate it only at night. This is the most efficient time. If the nights are cool enough we will exhaust the inside heat using a window fan. During the day we will shut the south facing blinds to eliminate a large portion of the solar heat gain.

In the near future we will be building our new home incorporating all the latest energy saving measures. Reducing our energy usage is one way we can make a significant contribution to saving our planet.

### Access

Authors: Tim and Betty Gulden, 731 East Front Street, Apt. 4D, Winona, MN 55987.

Shower Head: Real Goods, 966 Mazzone Street, Ukiah, CA 95482 • 1-800-762-7325

Fluorescent Lights: Lights of America, Walnut, CA 91789. Purchased from a local large retail store.

Power Consumption of Four Apartments  
Apt. 4 got the "efficiency job"

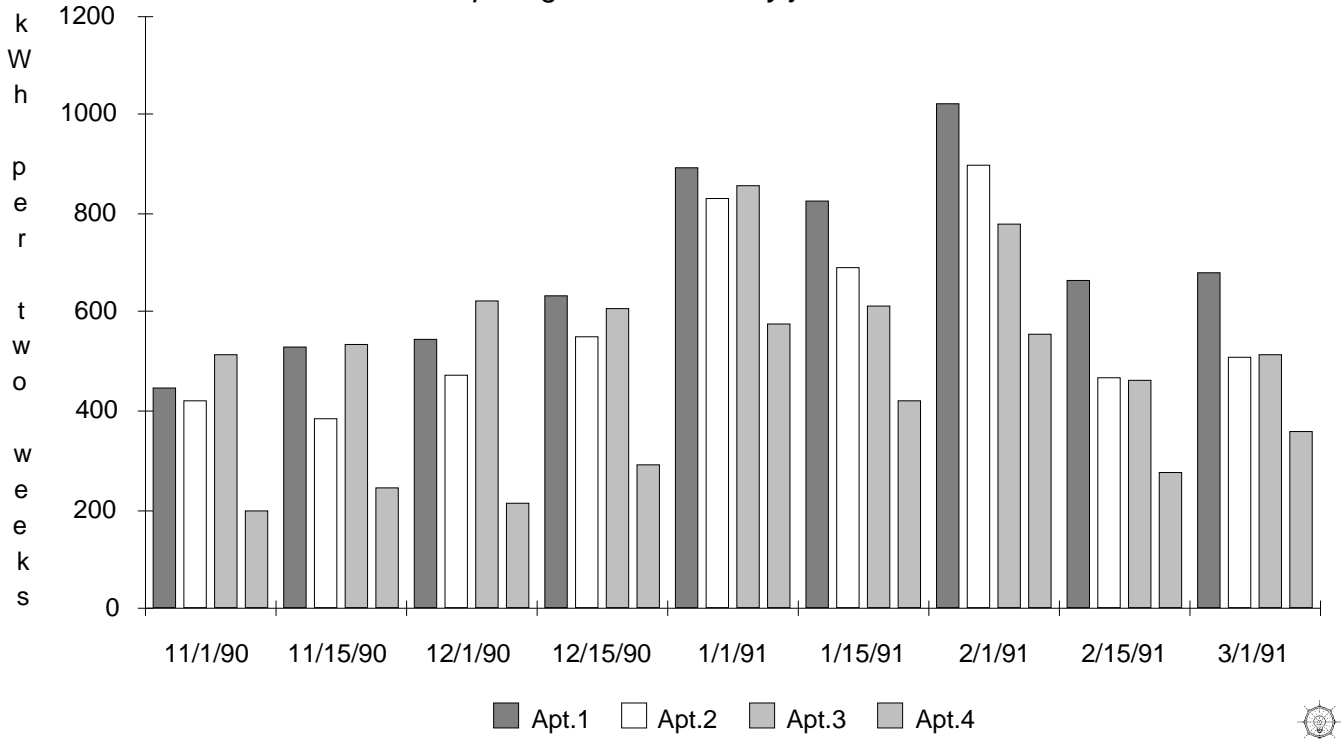

ENERGY  
DEPOT  
AD

## UPGRADABLE 400-700-1300 WATT INVERTERS

### *The inverter that can grow with your system!*

- Easily upgradable for more power output
- Input voltage- 10.5 to 16.5 VDC
- Output voltage- 115 vac true RMS  $\pm 5\%$
- Idle current- 60 mA. Appliances start immediately!
- Two year warranty
- Automatic protection for: input overvoltage, output overload and overtemperature.
- Efficiency- over 90% at half rated power
- Low battery voltage warning buzzer- 10.85 VDC
- Low battery voltage automatic shutdown - 10.5 VDC
- Small size- 3.15" x 3.3" x 11" weighs less than 5 pounds

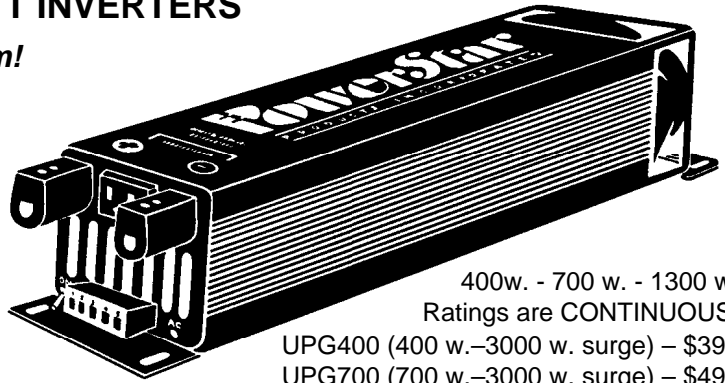

400w. - 700 w. - 1300 w.  
Ratings are CONTINUOUS!  
UPG400 (400 w.-3000 w. surge) - \$399  
UPG700 (700 w.-3000 w. surge) - \$499  
UPG1300 (1300 w.-6000 w. surge) - \$799

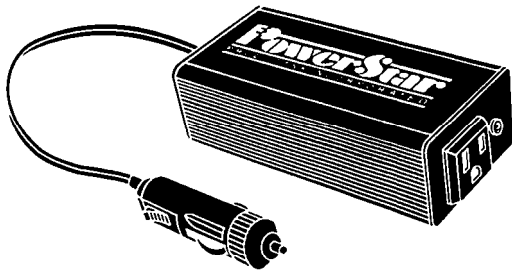

### The POW 200 Inverter

*The UPG series' little brother*

- 400 watts peak • 200 watts for two minutes • 140 watt continuously • Automatic protection for over load and over temp. • Plugs into car lighter • Tiny size- 5" x 2.6" x 1.7" • Weighs less than a pound. POW 200 - \$149.95



**Things that Work!**  
tested by Home Power

10011 North Foothill Boulevard  
Cupertino, CA 95014  
(408) 973-8502 • FAX (408) 973-8573

# Nickel Cadmium Batteries

*"In Nicads We Trust!"*

**Now Available!**

**NIFE 247 Ampere-Hour, 12 Volt NiCad**

**Only \$1013.00**

Just in: No longer needed, underwater mine batteries. Large Stock of 1.5 and 6 Volt Primary batteries. Never used. Still in original boxes. Mine not included. \$2.00 each, minimum order 4. Shipped prepaid in Continental US.

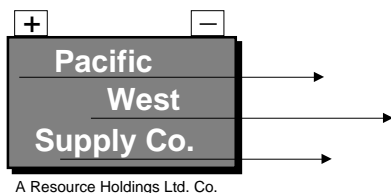

A Resource Holdings Ltd. Co.

## Pacific West Supply Co.

16643 SW Roosevelt  
Lake Oswego, OR 97035

(503) 835-1212 • FAX (503) 835-8901

# A Primer on Wind Generators

Mike Bergey

©1991 Michael Bergey

**T**he wind has been an important source of energy in the U.S. for a long time. The mechanical windmill was one of the two "high-technology" inventions (the other was barbed wire) of the late 1800's that allowed us to develop much of our western frontier. Over 8 million mechanical windmills have been installed in the U.S. since the 1860's and some of these units have been in operation for more than a hundred years. Back in the 1920's and 1930's, before the REA began subsidizing rural electric coops and electric lines, farm families throughout the Midwest used 200-3,000 watt wind generators to power lights, radios, and kitchen appliances. The modest wind industry that had built up by the 1930's was literally driven out of business by government policies favoring the construction of utility lines and fossil fuel power plants.

## A Little History

In the late 1970's and early 1980's intense interest was once again focused on wind energy as a possible solution to the energy crisis. As homeowners and farmers looked to various electricity producing renewable energy alternatives, small wind turbines emerged as the most cost effective technology capable of reducing their utility bills. Tax credits and favorable federal regulations (PURPA) made it possible for over 4,500 small, 1-25 kW, utility-intertied wind systems to be installed at individual homes between 1976-1985. Another 1,000 systems were installed in various remote applications during the same period. Small wind turbines were installed in all fifty States. None of the small wind turbine companies, however, were owned by oil companies, so when the federal tax credits expired in late 1985, and oil prices dropped to \$10 a barrel two months later, most of the small wind turbine industry once again disappeared. The companies that survived this "market adjustment" and are producing small wind turbines today are those whose machines were the most reliable and whose reputations were the best.

## The Cost Factor

Photovoltaics is an attractive technology in many ways, but cost is not one of them. Small wind turbines can be an attractive alternative to those people needing more than 100-200 watts of power for their home, business, or remote facility. Unlike

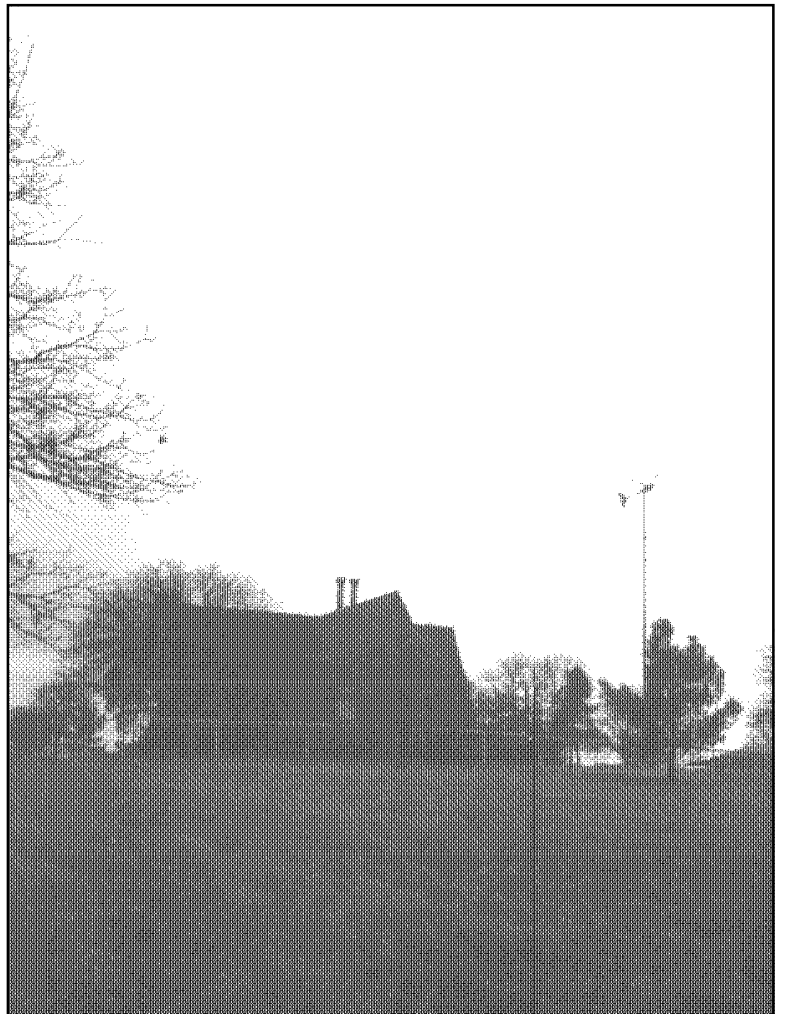

PVs, which stay at basically the same cost per watt independent of array size, wind turbines get less expensive with increasing system size. At the 50 watt size level, for example, a small wind turbine would cost about \$9.00/watt compared to \$6.60/watt (PV costs have increased about 10% in the last year) for a PV module. This is why, all things being equal, PV is less expensive for very small loads. As the system size gets larger, however, this "rule-of-thumb" reverses itself. At 250 watts the wind turbine costs are down to \$3.50/watt, while the PV costs are still at \$6.60/watt. For a 1,500 watt wind system the cost is down to \$1.93/watt and at 10,000 watts the cost of a wind generator (excluding electronics) is down to \$1.15/watt. The cost of regulators and controls is essentially the same for PV and wind. Somewhat surprisingly, the cost of towers for the wind turbines is about the same as the cost of equivalent PV racks and trackers.

For homeowners connected to the utility grid, small wind turbines are usually the best "next step" after all the conservation and efficiency improvements have been made. A typical home consumes between 800-2,000 kWh of electricity per month and a 5-10 kW wind turbine or PV system is about the right size to meet this demand. At this size wind turbines are much less expensive.

### Wind Energy

Wind energy is a form of solar energy produced by uneven heating of the Earth's surface. Wind resources are best along coastlines, on hills, and in the northern states, but usable wind resources can be found in most areas. As a power source wind energy is less predictable than solar energy, but it is also typically available for more hours in a given day. Wind resources are influenced by terrain and other factors that make it much more site specific than solar energy. In hilly terrain, for example, you and your neighbor are likely to have the exact same solar resource. But you could have a much better wind resource than your neighbor because your property is on top of the hill or it has a better exposure to the prevailing wind direction. Conversely, if your property is in a gully or on the leeward side of the hill, your wind resource could be substantially lower. In this regard, wind energy must be considered more carefully than solar energy.

Wind energy follows seasonal patterns that provide the best performance in the winter months and the lowest performance in the summer months. This is just the opposite of solar energy. For this reason wind and solar systems work well together in what are called "hybrid

systems". These hybrid systems provide a more consistent year-round output than either wind-only or PV-only systems. One of the most active market segments for small wind turbine manufacturers is PV-only system owners who are expanding their system with wind energy.

### Wind Turbines

Most wind turbines are horizontal-axis propeller type systems. Vertical-axis systems, such as the egg-beater like Darrieus and S-rotor type Savonius type systems, have proven to be more expensive. A horizontal-axis wind turbine consists of a rotor, a generator, a mainframe, and, usually, a tail. The rotor captures the kinetic energy of the wind and converts it into rotary motion to drive the generator. The rotor usually consists of two or three blades. A three blade unit can be a little more efficient and will run smoother than a two blade rotor, but they also cost more. The blades are usually made from either wood or fiberglass because these materials have the needed combination of strength and flexibility (and they don't interfere with television signals!).

The generator is usually specifically designed for the wind turbine. Permanent magnet alternators are popular because they eliminate the need for field windings. A low speed direct drive generator is an important feature because systems that use gearboxes or belts have generally not been reliable. The mainframe is the structural backbone of the wind turbine and it includes the "slip-rings" that connect the rotating (as it points itself into changing wind directions) wind turbine and the fixed tower wiring. The tail aligns the rotor into the wind and can be a part of the overspeed protection.

A wind turbine is a deceptively difficult product to develop and many of the early units were not very reliable. A PV module is inherently reliable because it has no moving parts and, in general, one PV module is as good as the next. A wind turbine, on the other hand, must have moving parts and the reliability of a specific machine is determined by the level of skill used in its engineering and design. In other words, there can be a big difference in reliability, ruggedness, and life expectancy from one brand to the next.

### Towers

A wind turbine must have a clear shot at the wind to perform efficiently. Turbulence, which both reduces performance and "works" the turbine harder than smooth air, is highest close to the ground and diminishes with



height. Also, wind speed increases with height above the ground. As a rule of thumb, you should install the wind turbine on a tower such that it is at least 30 ft above any obstacles within 300 ft. Smaller turbines typically go on shorter towers than larger turbines. A 250 watt turbine is often, for example, installed on a 30-50 ft tower, while a 10 kW turbine will usually need a tower of 80-100 ft.

The least expensive tower type is the guyed-lattice tower, such as those commonly used for ham radio antennas. Smaller guyed towers are sometimes constructed with tubular sections or pipe. Self-supporting towers, either lattice or tubular in construction, take up less room and are more attractive but they are also more expensive. Telephone poles can be used for smaller wind turbines. Towers, particularly guyed towers, can be hinged at their base and suitably equipped to allow them to be tilted up or down using a winch or vehicle. This allows all work to be done at ground level. Some towers and turbines can be easily erected by the purchaser, while others are best left to trained professionals. Anti-fall devices, consisting of a wire with a latching runner, are available and are highly recommended for any tower that will be climbed. Aluminum towers should be avoided because they are prone to developing cracks. Towers are usually offered by wind turbine manufacturers and purchasing one from them is the best way to ensure proper compatibility.

**Remote Systems Equipment**

The balance-of-systems equipment used with a small wind turbine in a remote application is essentially the same as used with a PV system. Most wind turbines designed for battery charging come with a regulator to prevent overcharge. The regulator is specifically designed to work with that particular turbine. PV regulators are generally not suitable for use with a small wind turbine. The output from the regulator is typically tied into a DC source center, which also serves as the connection point for other DC sources, loads and the batteries. For a hybrid system the PV and wind systems are connected to the DC source center through separate regulators, but no special controls are generally required.

For small wind turbines a rule-of-thumb is that the AH capacity of the battery bank should be at least six times the maximum charging current, including any PV elements.

**Being Your Own Utility Company**

The federal PURPA regulations passed in 1978 allow you to interconnect a suitable renewable energy powered generator to your house or business to reduce your consumption of utility supplied electricity. This same law requires utilities to purchase any excess electricity production at a price ("avoided cost") usually below the retail cost of electricity. In about a dozen states with "net energy billing options" small systems are actually allowed to run the meter backwards, so they get the full retail rate for excess production. Because of the high overhead costs to the utilities for keeping a few special

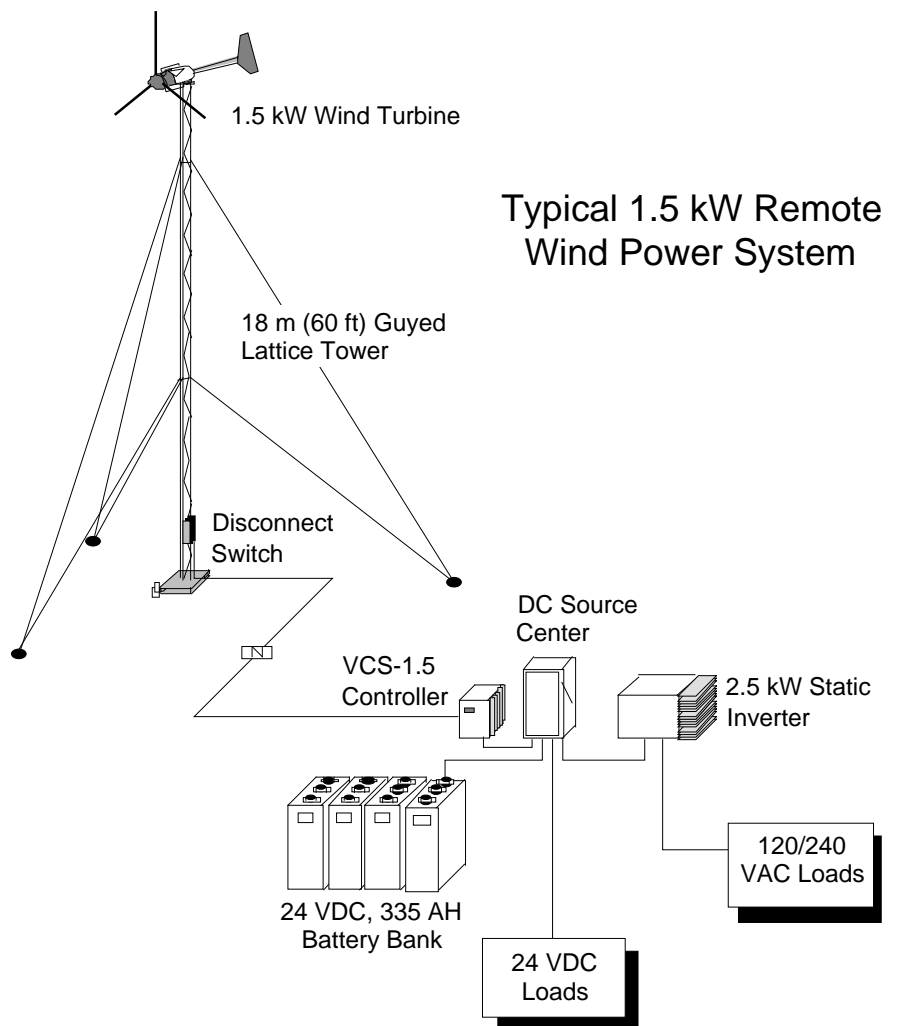

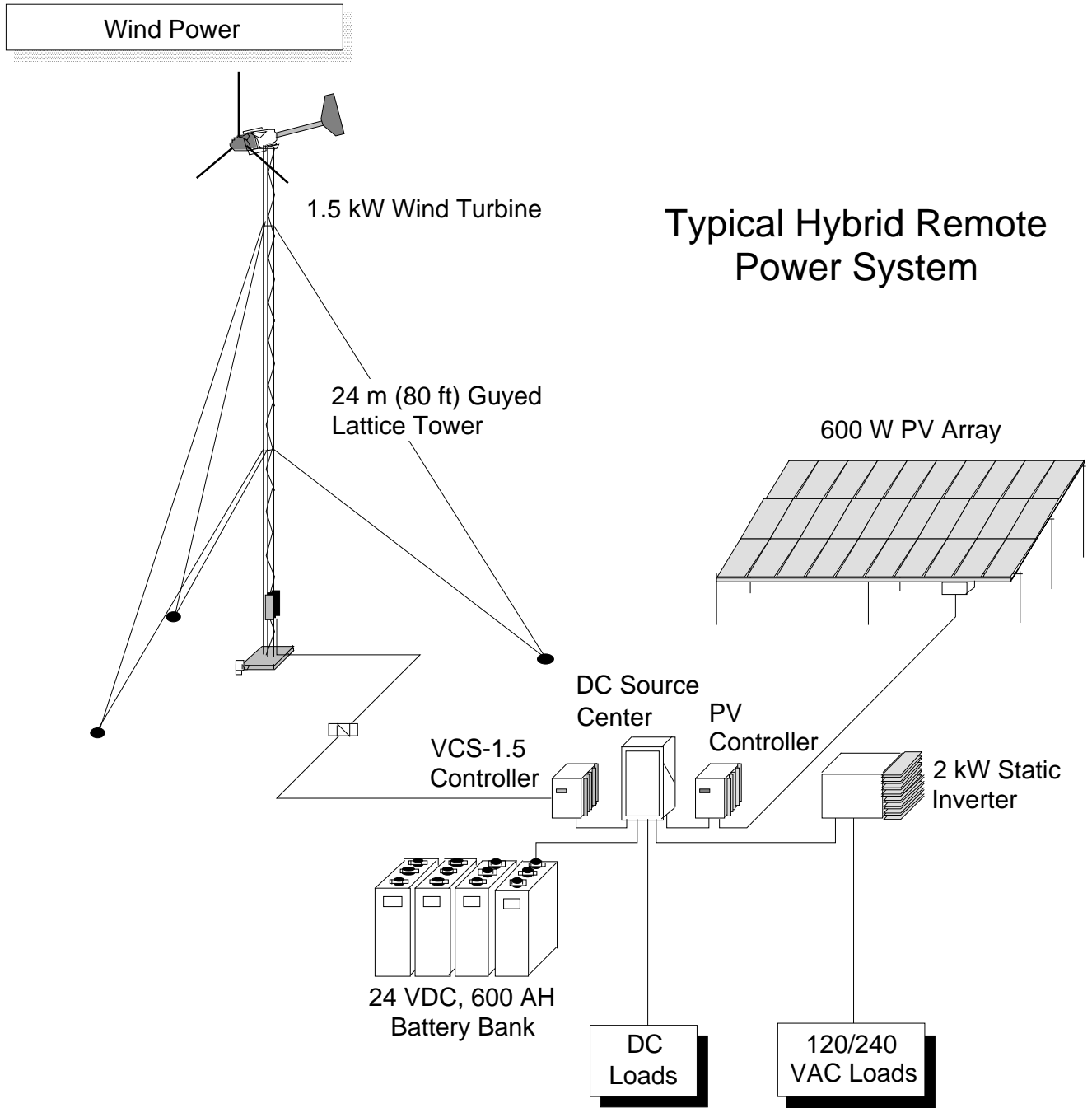

## Typical Hybrid Remote Power System

hand-processed customer accounts, net energy billing is actually less expensive for them.

These systems do not use batteries. The output of the wind turbine is made compatible with utility power using either a special kind of inverter (line-commutated) or an induction generator. The output is then connected to the household breaker panel on a dedicated breaker, just like a large appliance. When the wind turbine is not operating, or it is not putting out as much electricity as the house needs, the additional electricity needed is supplied by the

utility. Likewise, if the turbine puts out more power than the house needs the excess is instantaneously sold to the utility. In effect, the utility acts as a very big battery bank and the utility sees the wind turbine as a negative load. After over 200 million hours of interconnected operation we now know that small utility-interconnected wind turbines are safe, do not interfere with either utility or customer equipment, and do not need any special safety equipment to operate successfully.

Hundreds of homeowners around the country who

installed 4-12 kW wind turbines during the go-go tax credit days in the early 1980's now have everything paid for and enjoy monthly electrical bills of \$8-30, while their neighbors have bills in the range of \$100-200 per month. The problem, of course, is that these tax credits are long gone and without them most homeowners will find the cost of a suitable wind generator prohibitively expensive. A 10 kW turbine (the most common size for homes), for example, will typically cost \$19,000-24,000 installed. For those paying 10 cents/kilowatt-hour or more for electricity in an area with an average wind speed of 10 mph or more, and with an acre or more of property (the turbines are big), a residential wind turbine may be worth considering. There is, to be sure, a certain thrill that comes from seeing your utility meter turn backwards.

### Performance

The rated power for a wind turbine is not a good basis for comparing one product to the next. This is because manufacturers are free to pick the wind speed at which they rate their turbines. If the rated wind speeds are not the same then comparing the two products is very difficult. Fortunately, the American Wind Energy Association has adopted a standard method of rating energy production performance. Manufacturers who follow the AWEA standard will give information on the Annual Energy Output (AEO) at various annual average wind speeds. These AEO figures are like the EPA Estimated Gas Mileage for your car, they allow you to compare products fairly, but they don't tell you just what your actual performance will be ("Your Performance May Vary").

Wind resource maps for the U.S. have been compiled by the Department of Energy. These maps show the resource by "Power Classes" that mean the average wind speed will probably be within a certain band. The higher the Power Class the better the resource. We say probably because of the terrain effects mentioned earlier. On open terrain the DOE maps are quite good, but in hilly or mountainous terrain they must be used with great caution. The wind resource is defined for a standard wind sensor height of 33 ft (10 m), so you must correct the average wind speed for wind tower heights above this height before using the AEO information supplied by the manufacturer. Wind turbine performance is also usually derated for altitude, just like an airplane, and for turbulence.

As a rule of thumb wind energy should be considered if your average wind speed is above 8 mph (most, but not all, Class 1 and all other Classes) for a remote application

## WINDFARMS

Starting in the early 1980's, larger wind turbines were developed for "windfarms" that were being constructed in windy passes in California. In a windfarm a number of large wind turbines, typically rated between 100-400 kW each, are installed on the same piece of property. The output of these units is combined and sold under contract to the utility company. The windfarms are owned by private companies, not by the utilities. Although there were some problems with poorly designed wind turbines and overzealous salesmen at first, windfarms have emerged as the most cost effective way to produce lots of electrical power from solar energy. There are now over 16,000 large wind turbines operating in the California windfarms and they produce enough electricity to supply a city the size of San Francisco. Large wind turbine prices are coming down steadily and even conservative utility industry planners project massive growth in windfarm development in the coming decade, most of it occurring outside California. One recent study actually called North Dakota the "Saudi Arabia of wind energy". With the federal governments "hands-off" energy policy, however, a key question is whether the thousands of large wind turbines that will be installed in the years ahead will be built in the U.S. or imported.

and 10 mph (Class 2 or better) for a utility-intertied application. If you live in an area that is not too hilly then the DOE wind resource map can be used to fairly accurately calculate the expected performance of a wind turbine at your site. In complex terrain a judgment on the site's exposure must be made to adjust the average wind speed used for this calculation. In most situations it is not necessary to monitor the wind speed with a recording anemometer prior to installing a small wind turbine. But in some situations it is worth spending \$300-1,000 and waiting a year to perform a wind survey. Manufacturers and equipment dealers can help sort out these questions.

### Keeping Current

Unfortunately, there are few good books available on wind energy. Most you will find were written 8-12 years

FULL  
PAGE  
CHART  
OF  
WIND  
POWER  
IN  
THE  
USA

ago and weren't very good to begin with. Now they will give you more bad information than good. The best book was Wind Energy, How to Use It by Paul Gipe, but you will be lucky to find a copy of this out-of-print paperback. Another good one was Wind Power for the Homeowner by Donald Marier, which may still be available through Rodale Press or in your local library.

For diehards, an international magazine "Wind Power Monthly" is available for \$50/yr from:  
P.O. Box 49007, Ste. 217,  
Redding, CA 96099-6007.

The best way to keep current with the progress of wind energy development, both small and large scale, in the U.S. is to join the:

American Wind Energy Association  
777 N Capitol St., NE,  
Ste 805,  
Washington, DC 20002;  
Tel: 202-408-8988).

A \$35/year individual membership brings a newsletter and an opportunity to help push legislation to promote the increased use of wind energy and other renewables.

**Access**

Author: Michael Bergey,  
Bergey Windpower, Inc.,  
2001 Priestley Avenue,  
Norman, OK 73069 •  
405-364-4212.



# SIEMENS

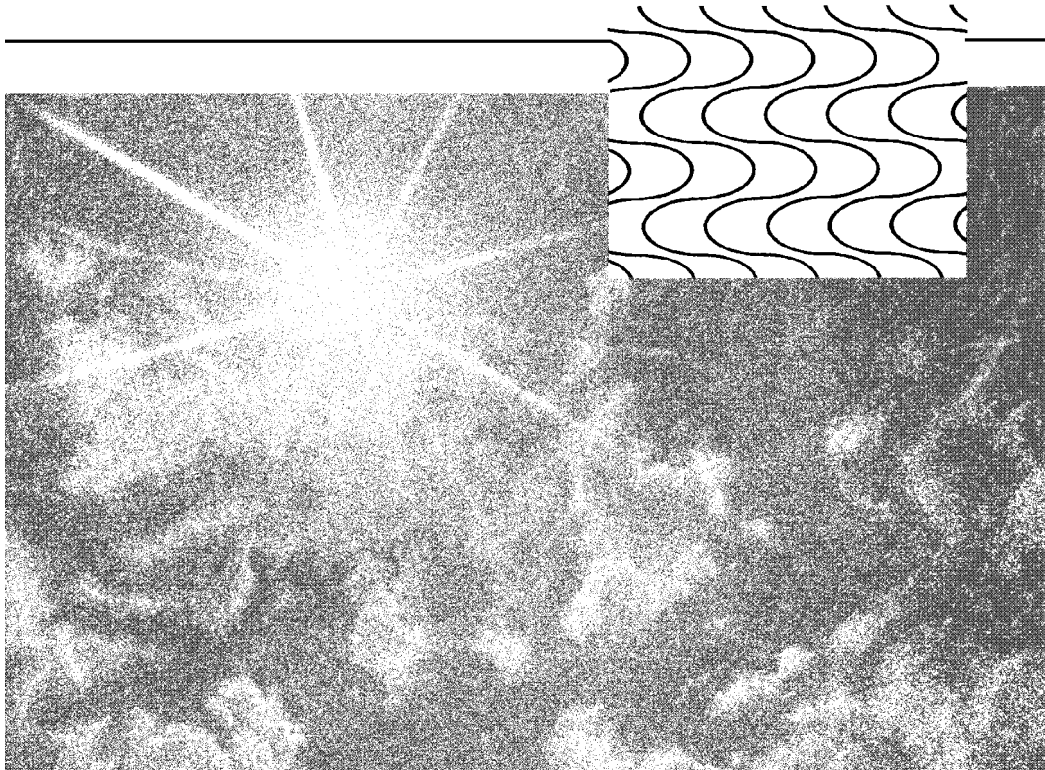

## Sun Power

Siemens solar industries photovoltaic power systems offer you a way to use the sun to produce your own electricity. All solar electric systems are not the same. There are important differences:

- **Design:**

Siemens Solar modules are engineered for maximum power output, use minimum space and operate silently.

- **Construction**

A module that is rugged, lightweight and easy to install. And Siemens cells are exceptionally reliable.

- **Versatility**

Siemens solar cells power RVs, remote homes, boats and telecommunication systems.

- **Warranty**

And all UL® Listed solar electric power modules carry Siemens' 10 year warranty.

- **Experience**

One in every four solar cells in the world is a Siemens cell.

- **Service**

Siemens Solar systems are backed by a dedicated, factory-trained sales and service network.

The New World Leader in Solar Technology

WM. LAMB CORP.

*Electricity from the Sun*

FOR YOUR SOLAR SOLUTIONS AND ENERGY NEEDS WE HAVE - -

- **SIEMENS SOLAR MODULES**

- **POWERSTAR UPGRADABLE INVERTERS**

- **HELIOTROPE INVERTERS & CONTROLLERS**

- **SPECIALTY CONCEPTS CONTROLLERS**

- **TROJAN BATTERIES**

- **DEALER INQUIRIES WELCOME •**

Wm. Lamb Corp.

P.O. Box 4185, North Hollywood, CA 91607 U.S.A. • 10615 Chandler Blvd., North Hollywood, CA 91601 U.S.A.

(818) 980-6248 • FAX (818) 980-0856



Siemens Solar Industries



Things that Work!  
tested by Home Power

# Things that Work!

## PowerStar's UPG1300 Inverter

Richard Perez and Bob-O Schultze

**S**ome devices set new standards for performance and value. This new PowerStar inverter is such a device. The UPG series inverters are the slickest way to make 120 vac out of battery power that I have ever used. It is powerful- 1,300 Watts continuous with surge capacity to 6,000 W. It is very quiet- both to the human ear, and to radios & TVs. It is efficient- between 89% and 98% by our testing. The PowerStar UPG revolutionizes inverters.

### Shipping & Documentation

The PowerStar UPG1300 arrived in fine shape in a small box. Most inverters this powerful weigh between 25 and 50 pounds and require a special shipping carton. This five pound inverter can go in a shoebox. The UPG is very small about 3 inches by 3 inches by 11 inches.

The documentation is simple to understand, direct and to the point. It gives the user all the information needed to install and effectively use the inverter.

### The UPG's Specifications

The inverter we tested is the largest of the UPG line. PowerStar's UPG line begins with a 400 watt model, which is upgradable to 700 watts, which is upgradable to 1,300 watts. This is in itself revolutionary. This is the first expandable inverter. It allows the user to start small and add more watts as they are needed or can be afforded. These ratings are CONTINUOUS, not time de-rated like the specs on virtually every other inverter. The surge rating on the 400 and 700 watt model is 3,000 watts. The 1,300 watt model surges to 6,000 watts.

The UPG series is a modified sine-wave inverter. It uses a high frequency ( $\approx 30$  kHz.) DC to DC switching power supply rather than a large transformer running at 60 cycles per second. The high voltage DC is then chopped by field effect transistors into the modified-sine wave 120 vac. This accounts for its tiny size and light weight. At five pounds, it is less than one-sixth the weight of any other inverter in its power range.

The UPG series operates over a wider voltage range than any other 12 Volt inverter. It happily makes power anywhere between 10.5 VDC and 16.5 VDC. This makes it ideal for nickel-cadmium or nickel-iron battery systems.

This is possible because the UPG uses the high frequency DC/DC switcher technique rather than the 60 Hz. transformer technique.

### The Test System

I installed the UPG1300 on Agate Flat in our PV/nicad test system. This system is sourced by two photovoltaic modules (one ARCO 47 W. and one Solarex 55 W.) through a photovoltaic regulator (a Heliotrope CC20). The PowerStar UPG inverter is wired directly to a 12 Volt, 100 Ampere-hour battery (ten series connected Alcad nickel-cadmium cells).

The UPG has all electrical connections and the on/off switch located on one end of its 3" X 3" square tube. A fan is located at the other end of the eleven inch long square tube. The high quality, color coded 12 VDC connectors are large enough to accept #2 wire and are tightened by an allen wrench supplied with the inverter. The 120 vac output is by a single three prong female receptacle and via a strip of connectors. The UPG can also be remotely activated via this connector strip.

The UPG powered a variety of 120 vac loads during the "user" phase of our testing. We non-technically used it to power whatever we needed. Some of the appliances we powered are a satellite TV system, a one hp ShopVac, a microwave oven, an AM/FM/Short Wave radio, a plethora of Osram EL series fluorescent lights, several "wall-cube" power supplies for flashlight battery recharging, and a coffee grinder.

### "User" Test Results

The first thing we noticed was how quiet this inverter is. In the audio spectrum, the only noise the inverter makes is when the fan operates. This inverter is very quiet.

When we were doing the technical testing, Bob-O couldn't believe it was operating and had to put his ear on the inverter to hear anything at all. In the radio spectrum, the UPG is the quietest high frequency DC/DC switcher inverter we have ever used. This is not to say it is totally without radio frequency interference (RFI), there is still some. The UPG is two to five times quieter than any other type we've ever used. It produces less glitches on the satellite system, less noise on the AM radio, and less noise on the shortwave receiver.

We successfully operated all the equipment listed above. Of particular note is the ShopVac. This one horsepower cannister vacuum is a large and demented load. It has already killed two inverters that couldn't cope with it's surge demand and inductive feedback. Not only did the UPG run this vacuum, but it did it better than inverters twice its size and cost. The ShopVac's motor was very happy with the UPG's power. The motor ran as quickly as it does on grid power and it ran cooler.

I also noticed that the small wall-cube power supplies put out more power than on any other inverter. Most of these supplies would only recharge small batteries at about half power on other inverters. With the UPG, these supplies put out just like downtown.

Since the inverter only consumes about one Watt on idle, we left it on all the time. This inverter doesn't have to put itself to sleep to save power. It can stay awake all the time and make power for small 120 vac devices like wall-cube power supplies. In the past, it has been very

inefficient to keep an inverter operating all night just to power a phone answering machine or other small 120 vac load. The UPG inverter is going to change the way systems are designed and operated.

**Technical Testing**

After such a successful user test, we couldn't wait to stick it to this inverter. Bob-O Schultze came to Home Power central to witness the event. We lined up all the monster loads, broke out the two Fluke 87 meters, and proceeded. We used a 0.5% precision shunt (50 mV. at 200 Amperes) in series with the battery/inverter cable. What follows below is a spreadsheet showing the raw data of an afternoon's rigorous testing.

**Notes on the data**

Watts are calculated fields for both 12 VDC and 120 vac wattages. This was done by multiplying volts times amps. Efficiency is the output wattage divided by the input wattage. The hard facts are in the spreadsheet, no editorial verbiage here!

**Conclusions from the data and tech tests**

This is one fine inverter. It powered up its rated output of 1300 watts. It survived overloading of 1500 Watts output for five minutes and thirty seconds, then it shut itself off. No damage. It survived overvoltage on its input. Here I disconnected the battery and left the inverter on line with the open circuit PV array. The voltage went to over 19 VDC and the UPG shut itself off with no damage. The low voltage shut down function works at 10.5 VDC as specified.

**POWERSTAR UPG1300 INVERTER TEST**

| INPUT DATA         |         |          | OUTPUT DATA         |          |          |           |                       |  |  |
|--------------------|---------|----------|---------------------|----------|----------|-----------|-----------------------|--|--|
| ON THE 12 VDC SIDE |         |          | ON THE 120 VAC SIDE |          |          |           |                       |  |  |
| Battery Volts      | Amps IN | Watts IN | Vpeak OUT           | Vrms OUT | amps OUT | watts OUT | Calculated Efficiency | Type of Load(s)                        |  |
| 15.37              | 1.8     | 27.7     | 182.0               | 119.4    | 0.23     | 27.1      | 98.0%                 | 25W Bulb.                              |  |
| 15.15              | 6.4     | 97.0     | 176.8               | 117.5    | 0.81     | 94.6      | 97.6%                 | 100W. Bulb                             |  |
| 15.05              | 8.0     | 120.4    | 174.8               | 117.0    | 1.00     | 117.0     | 97.2%                 | 25W & 100W Bulb                        |  |
| 14.22              | 24.8    | 352.7    | 165.2               | 113.8    | 2.76     | 314.3     | 89.1%                 | 100W Bulb & 200W Heat Lamp             |  |
| 13.65              | 37.6    | 513.2    | 156.8               | 112.1    | 4.14     | 464.1     | 90.4%                 | 260W Soldering Gun & 300W Bulbs        |  |
| 13.14              | 68.8    | 904.0    | 153.6               | 111.2    | 7.65     | 850.7     | 94.1%                 | 760W Shopvac & 300W Bulbs              |  |
| 12.85              | 92.8    | 1192.5   | 150.0               | 110.2    | 10.10    | 1113.0    | 93.3%                 | 600W Microwave Oven & 300W Bulbs       |  |
| 12.82              | 113.2   | 1451.2   | 151.2               | 111.4    | 12.30    | 1370.2    | 94.4%                 | 600W Microwave Oven & 760W Shopvac     |  |
| 12.46              | 134.0   | 1669.6   | 144.4               | 109.5    | 13.66    | 1495.8    | 89.6%                 | 600W Microwave&760W Shopvac&300W Bulbs |  |

## Things that Work!

The UPG series has a smart fan. Most inverters use a thermal switch to turn on the fan. The UPG uses current operated logic to activate the fan. This means the fan turns on BEFORE the inverter gets hot, instead of after.

### Efficiency

The efficiency of this inverter is very high. Especially at low output wattage. While 60 Hz. transformer based inverters have this same high efficiency around full power, they are very inefficient at low output power. The PowerStar UPG is uniformly very efficient. For example, consider the 25 watt lightbulb's test data on the spreadsheet. Here the UPG is 98% efficient. With a 25 watt load, most 1,000+ watt inverters are less than 30% efficient. We are so impressed with the uniformly high efficiency of the UPG that I have graphed it on this page. This graph uses our actual data from the spreadsheet.

### Peak Voltage Output

The reason that our ShopVac and wall cubes work so well on the UPG is because it maintains high peak and root-mean-square (rms) voltages. Ideally the peak output voltage should be about 164 vpp and the DC equivalent voltage output at 117 vrms. This is what the power grid strives to maintain (and often doesn't). The output performance of the UPG is head and shoulders above other DC/DC switcher types. Output voltage is more stable and in a more useful, higher range than any other type. This means better performance from electric motors, microwaves, wall-cubes, and virtually all 120 vac appliances. Once again, we're amazed and provide a graph of the data on the PowerStar's output voltage performance below.

*Efficiency vs. Output Power for PowerStar UPG1300*

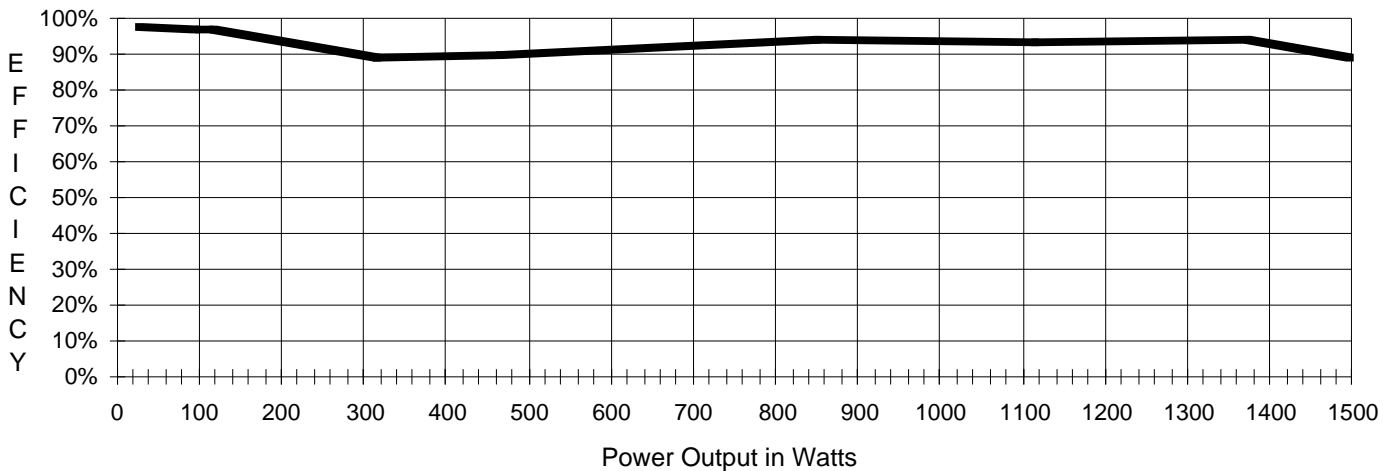

*Peak Voltage & RMS Voltage vs. Power Output for the PowerStar UPG1300*

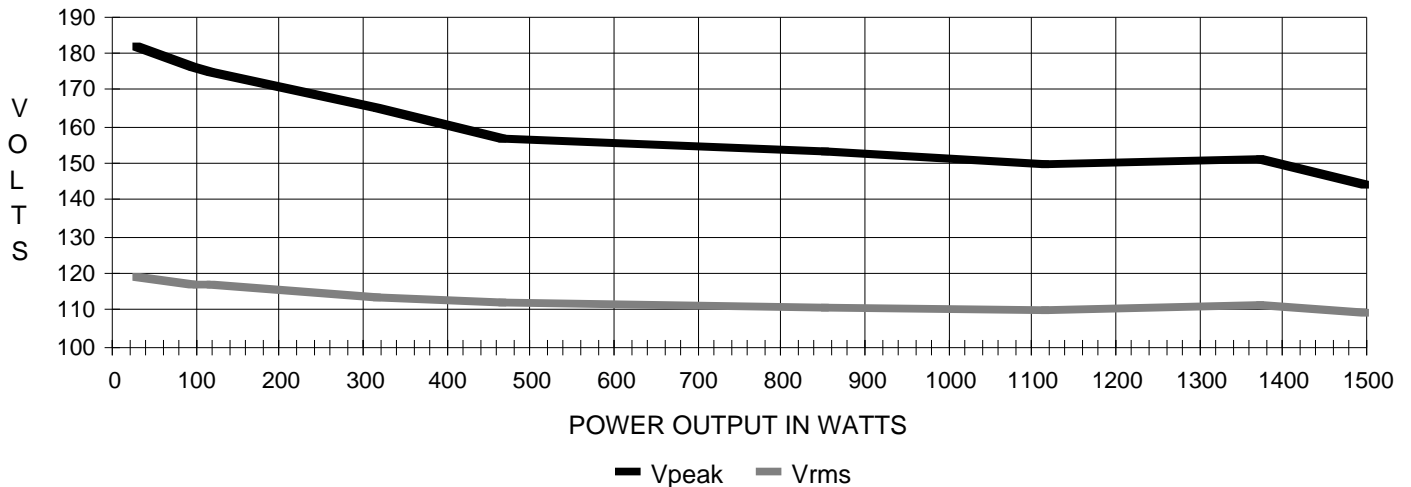



**UPG Cost**

The price of the 400 watt UPG model is \$399. The 700 watt UPG model costs \$499. The 1,300 watt model we tested costs \$799. At about 62¢ per continuous output watt, the UPG 1300 sets a new low price record for inverters. PowerStar's warranty for the UPG inverters is two years.

**Conclusions**

We really like this inverter. The unique operating features of this inverter will revolutionize how we design and use our systems. We most highly recommend it to Home Power readers.

**Access:**

Authors and Testers: Richard Perez & Bob-O Schultze, C/O Home Power, POB 130, Hornbrook, CA 96044 • 916-475-3179 or 916-475-3401.

Manufacturers: PowerStar Products Inc., 10011 North Foothill Blvd., Cupertino, CA 95014 • 408-973-8502.

**A Note on this particular "Things that Work!"**

*"Things that Work!" is just that. We don't waste your time, our time, and all this paper with negative reviews of equipment that doesn't work. These reviews are good reviews by definition. Products that don't work are not mentioned at all, but instead consigned to the oblivion they deserve. Only problem is that every so often a product comes by that is outstanding even among other "Things that Work!". This inverter causes me to reach deep in my bag of superlatives. Nuff said. RP.*



**KYOCERA  
AD**

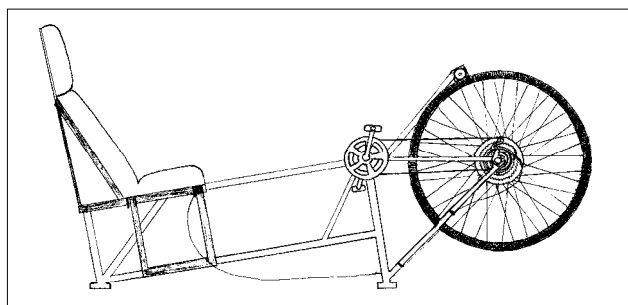

**THE POWER COMPANY**

- recumbent pedal power units
- bike generator adaptors
- complete home power packages
- catalogue \$1.00

P.O. BOX 178, RAINIER, WA 98576 • 206-458-3336

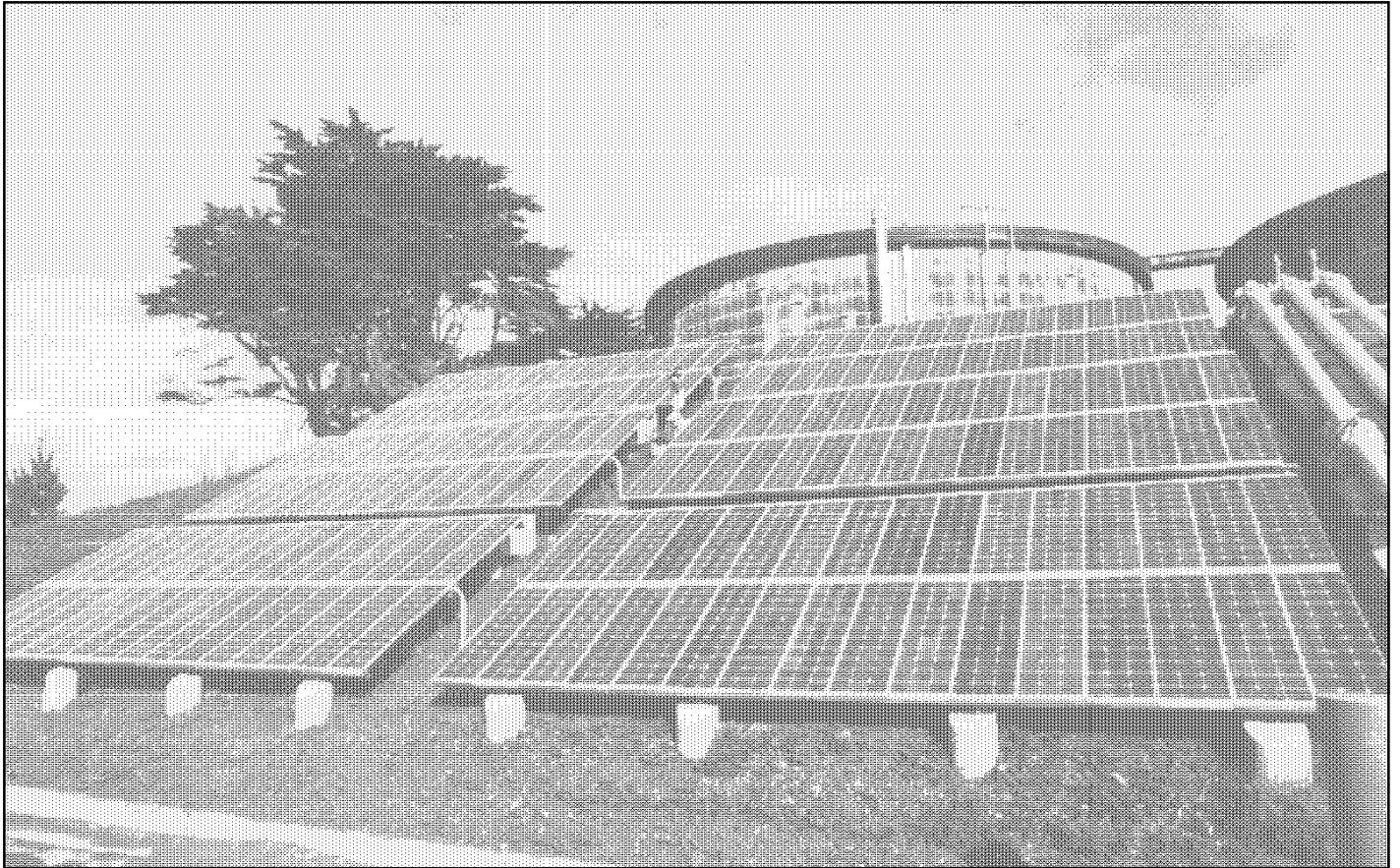

Above: 192 PV panels make electricity which is converted into hydrogen and then back to electricity by a fuel cell.

# The Schatz PV Hydrogen Project

Richard Perez

**M**any of us dream of more efficient ways to store the power we make from renewable energy sources. Here's a system that uses sunlight to make hydrogen and oxygen gas. These stored gases are converted directly into electricity by a fuel cell. Sound futuristic and impossible? Well, it's happening at Humboldt State University in Arcata, California.

## **An opportunity we couldn't refuse...**

I recently attended a conference on energy conservation at Humboldt State University. One of the conference's organizers, Michael Welch of the Redwood Alliance, suggested we visit an experimental PV/Hydrogen project at the school. It was an opportunity that we couldn't pass up. So, Bob-O Schultze and I saddled up and headed for the Humboldt Hydrogen.

## **The People**

Renewable power systems are born because someone decides to build them. It is the interest and intelligence of the system's inventors/designers/users that makes it a reality. The hardware is secondary to the human desire to do it. We have technology coming out of our ears and we still fight wars over the oil that is slowly killing us. Renewable energy is worthless if we don't use it.

The PV/Hydrogen project is the work of Dr. Peter Lehman and the crew of the Environmental Resources Engineering Dept. at Humboldt State.

Bob-O and I were prepared for an ivory-tower tour focusing on the age encrusted ideas chiseled indelibly in stone. What we found was entirely alive, open, and growing. These folks' project is as real as a Physics book, but their feet are dangling over the edge of energy reality, just like those of every home power producer. We instantly found ourselves at home with folks that shared the same dreams, concepts, and fears that we have. It was enough to make me want to go back to college.

### The Concept

Sunlight makes Hydrogen that makes Electricity.

The concept of the Schatz Solar Hydrogen Project is not very different from home power systems, with one exception. The power here is stored as hydrogen and oxygen gases rather than in a battery.

An 8,000 Watt photovoltaic array directly converts sunlight into electricity. The power of the array feeds an electrolyzer cell. The electrolyzer converts the array's power into hydrogen gas and oxygen gas by electrolysis of water. These gases are stored in tanks for use at night or on overcast days. The hydrogen and oxygen gases are fed into a fuel cell for direct conversion into DC electric power. The DC electricity, either from the array direct or from the fuel cell, is converted into 120 vac by an inverter. The load supplied by this system is the aeration compressor bubbling air into the Marine Lab's fish tanks. Talk about happy fish! They have an uninterruptible solar power supply to provide their air.

While the fish are happy, so are the folks working on this project. They are learning, hands-on, to apply hydrogen storage in a PV system. This learning experience is the real reason for the Schatz Solar Hydrogen Project. High-tech R&D projects and backwoods home power systems both learn about renewable energy the same way— by doing.

### The PV Array

The photovoltaic array contains 192 ARCO M75 modules wired for 24 VDC use. The array is broken into sub-arrays that are each individually controlled. Each module in the array is grounded and wired with #10 gauge, USE insulated copper wire. The output of each sub-array connects to the main system by #2 wire. Each sub-array is isolated from the rest of the array by a 60 Ampere Schottky diode.

### The Electrolyzer

The electrolyzer is a high pressure, bipolar, alkaline type. The electrolyzer contains 12 individual cells connected in series, each with a working voltage around 2 VDC. The electrolyzer cells use a 25% solution of potassium hydroxide (KOH) in water. The plates of the cells are made from stainless steel. This electrolyzer is made by Teledyne Energy for manufacturing processes that require pure hydrogen. It produces about 20 liters of hydrogen gas per minute and is between 75% and 80% efficient.

The gas output of the electrolyzer is metered by a mass flow calorimeter, a visual flow meter, and mechanical pressure gauges.

The oxygen gas is far from pure as it leaves the electrolyzer's cells. The oxygen output of the electrolyzer still contains small amounts of hydrogen gas and vast

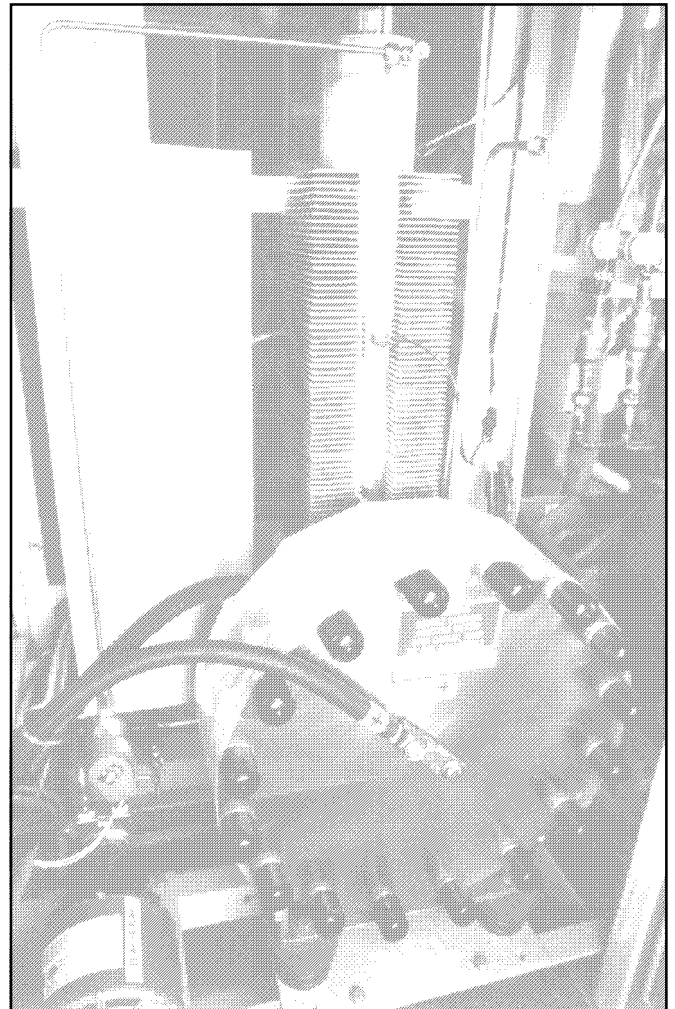

Above: the Electrolyzer.

PV/Hydrogen

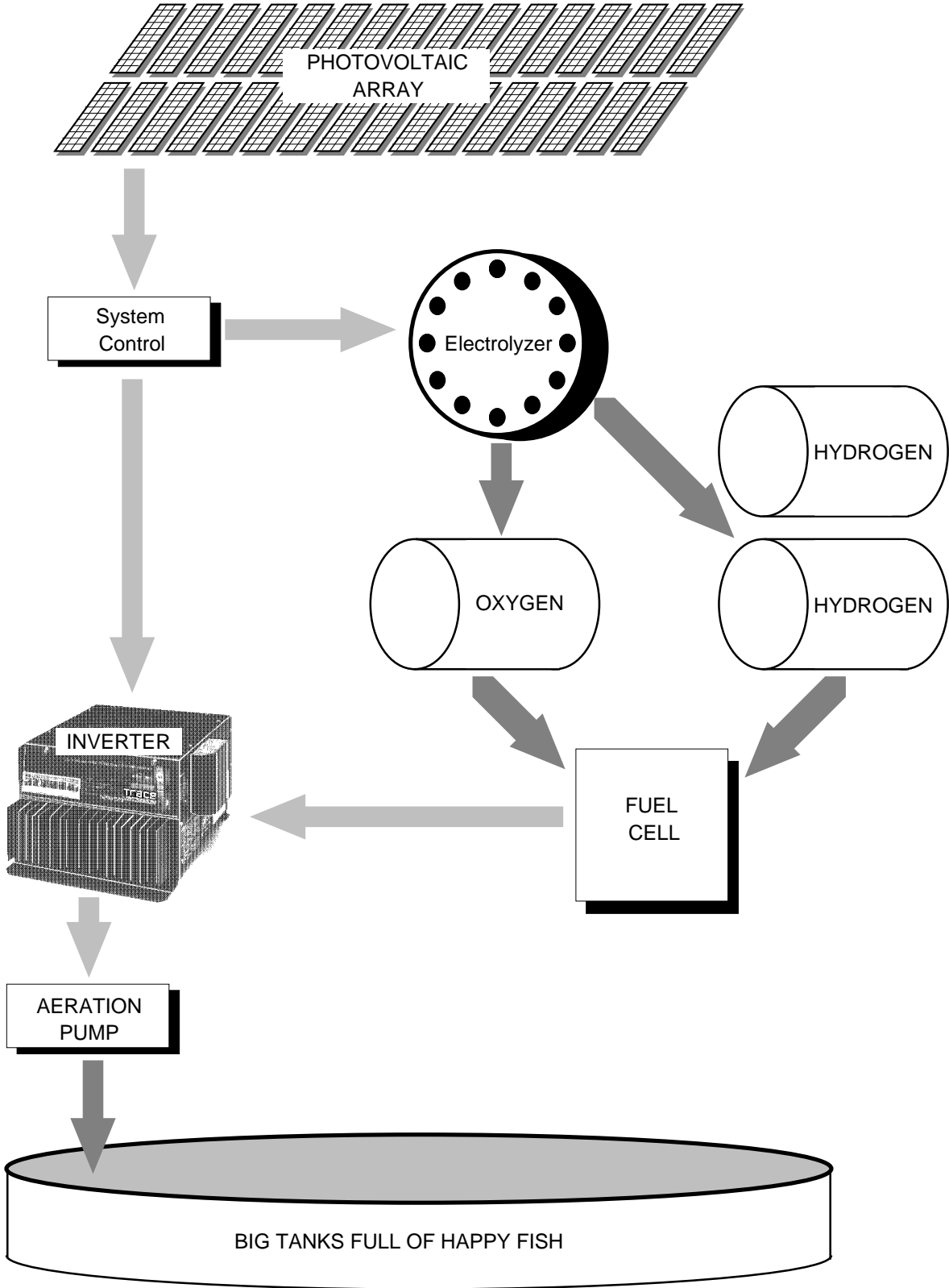

amounts of water vapor. The oxygen gas is first run into a tube-in-tube condenser that turns the water vapor into a liquid that is removed. The dryer oxygen gas then passes into a catalytic scrubber that combines the minute amounts of remaining hydrogen gas with the oxygen gas and produces water. The water is drained off and then the whole process of condenser/catalytic scrubber is repeated. The net result is very pure, very dry oxygen gas that is stored in the tank.

The electrolyzer requires only minimal maintenance—the replenishment of its electrolyte about every six months of continuous operation.

### The Storage System

Both the hydrogen and oxygen gases produced in the electrolyzer are stored for later use in the fuel cell. These gases are stored in three 500 gallon LPG tanks with a rated working pressure of 250 psi. Two red tanks hold the hydrogen and one green tank holds the pure oxygen. Working pressure in these tanks is 100 psi to 125 psi. These tanks use all the hydrogen accouterments of pressure relief valves, stainless steel piping and connectors, and thermocouples that act as "gas gauges"

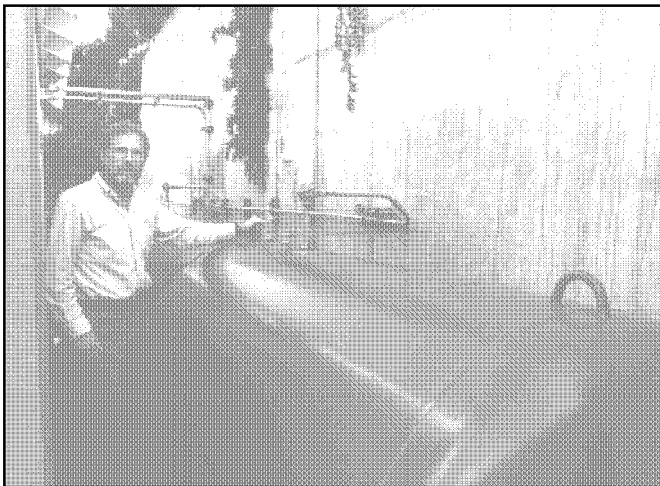

Above: Peter Lehman stands beside the oxygen storage tank. Behind him are two hydrogen tanks.

determining the amount of gas in the tank.

### The Fuel Cell

The fuel cell reverses the process carried on in the electrolyzer and converts the stored hydrogen and oxygen gases back into water. This process also releases DC electricity at the same time. On the day we visited the Schatz project, the fuel cell had been returned to its manufacturer for testing. When installed in the system, the fuel cell will enable the stored gases to be directly and

silently converted into electric power. The combination of the storage tanks and the fuel cell are roughly equivalent to the battery in a home power system. In contrast to batteries, fuel cells have no finite capacity. A fuel cell will produce power as long as it is fed hydrogen and oxygen. The storage capacity of the system is limited by the size of the hydrogen and oxygen tanks, not by the size of the fuel cell.

The outputs of the fuel cell are DC electricity and water. That's it. The entire system produces no polluting byproducts—no carbon dioxide, no sulfur dioxide, and no radioactive waste. The entire process is totally symmetrical. Water molecules are transformed into their elemental components of hydrogen and oxygen. The hydrogen and oxygen atoms are recombined into water molecules. The system's creators bank the solar energy in tanks and retrieve it when needed.

This particular fuel cell is made by Energenics of Ringwood, New Jersey. This fuel cell is a proton exchange membrane type that is capable of making effective use of the pure oxygen made by the electrolyzer. This fuel cell is an "instant-on" version that runs at lower temperatures (70°C.) than other versions (like the phosphoric acid version at 150°C. & the molten carbonate version at 800°C.). This Energenics version puts out 750 Watts continuously. The Energenics Company is working hand-in-hand with the Schatz project in research and development on retrieving energy stored in hydrogen.

### The Inverter

We expected to find a high-dollar, super inverter in such an advanced system. Instead, we found the same garden variety Trace Inverter used in thousands of home power households. A Trace 2032 Inverter hummed happily on the wall. It doesn't care if its DC power comes directly from the PV array during the day, or from the fuel cell at night. The Trace is very democratic, and very reliable; it keeps the fish alive & happy.

### System Control and Instrumentation

The instrumentation and control on the Schatz project are extensive. After all, the major product here is information. The system is monitored by computers at every stage of the process. Seven optoisolated, analog to digital converter boards talk to the system's two Macintosh computers.

System control is accomplished by shorting out individual sub-arrays. This is accomplished by computers controlling 30 Ampere relays. A bank of NIFE Sunica nickel-cadmium cells is floated on the array to act as a

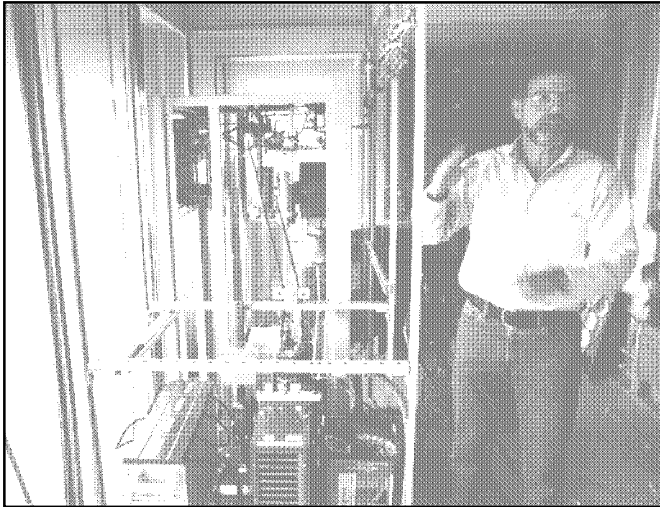

Above: Peter Lehman explains the system. The vacant space in the rack holds the fuel cell.

"flywheel" to prevent constant relay switching during power surges.

#### **The System's Safety**

A clear Lucite cage contains all hydrogen handling components. This cage vents outside and operates at less air pressure than the room in which it lives. Any hydrogen leaks are instantly detected by ultra sensitive hydrogen sniffers and the system is automatically shut down. All piping within the system is stainless steel. The electrical components are protected with every known fuse, breaker, and disconnect. The entire system will not only meet the NEC, but it will make the most paranoid electrical inspector feel safe. This PV/hydrogen installation is safer than your kitchen stove or hot water heater.

#### **The Reasons Why**

The first reason is to learn how to store PV produced power as hydrogen. The second reason is to learn how to retrieve this stored energy through a fuel cell. The Schatz project is research and development in the use of solar hydrogen.

The project is funded by Mr. L.W. Schatz, president of General Plastics Manufacturing Company of Tacoma, WA. My compliments to Mr. Schatz for looking far beyond the next quarter's profits and into an energy future we can all share.

#### **Hydrogen Home Power?**

Well, not yet. But, Peter Lehman and his compatriots are working on it. This system is far too costly and complex for basic home power right now. That's what Peter and

the crew are working on. In the future, when we're using hydrogen for power storage, then it will be because folks like the Humboldt crew did their work right now.

#### **Hopelessly Hi-Tech?**

Not on your life. After a morning of sunshine hydrogen flowing through polished stainless steel, we visited another project at Humboldt State— the Campus Center for Appropriate Technology (CCAT). CCAT makes renewable energy real right now. The CCAT building uses PVs and wind for power (battery storage here), solar hot water, efficient appliances, a solar greenhouse providing space heat as well as fresh veggies, and even composting toilets. The CCAT building houses students in the Environmental Resources Engineering program and gives them the same hands-on experiences lived by home power producers. These students get to live on renewable power on a daily basis, learn about the systems involved, and create their own variations. They are an intense crew. I could see their commitment from the well-thumbed copies of Home Power on their bookshelves. The students at CCAT were not only learning new things, but are willing to share what they have learned. They have promised to write about their experiences in the next issue of Home Power.

#### **Conclusion**

Hydrogen storage is coming. The students and faculty at Humboldt State are joyously pushing the edge of the energy envelope. When I was in school the only things under discussion were building better bombs and nukes too cheap to meter. To find an established center of learning with a heart and an eye to our future gives me great hope. As I said, "It makes me want to go back to school."

#### **Access**

Dr. Peter Lehman, Director of the Schatz Solar Hydrogen Project, Environmental Resources Engineering Dept., Humboldt State University, Arcata, CA 95521 •



INDEPENDENT  
ENERGY  
SYSTEMS

Photron  
Ad

Burden's  
Surplus  
Center

*the incredible*

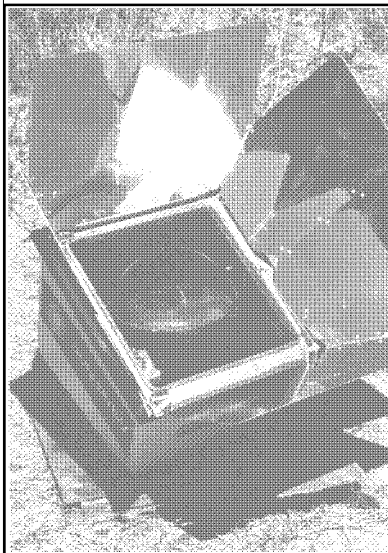

## SUN OVEN...

- TENDERIZES NATURALLY!
- COOKS EVENLY & SAFELY!
- HEATS TO 350-400 DEGREES F!
- IMPROVES THE TASTE OF FOOD!
- PAYS FOR ITSELF!
- HELPS SAVE THE ENVIRONMENT!

Introductory offer \$159. (Reg \$179.)  
INCLUDES UPS SHIPPING.

TO ORDER Call or write:

**SUNLIGHT ENERGY  
CORPORATION**

**1-800-338-1781**

**4411 W. Echo Ln., Glendale, AZ 85302**

"Sun Oven is well-made and should  
last a long time. I love it!"  
Karen Perez HP19.

Things that Work!



# Hydrogen Fuel

L.E. Spicer

©1991 L.E. Spicer

**H**ydrogen is an abundant fuel and it is simple to make. Above the initial cost of the generating equipment, the hydrogen produced can be free. The only substances used up in making hydrogen are water and electricity. My electricity comes from a wind generator and the water I use is rainwater. By using solar cells, the entire process can be done without one moving part.

## Hydrogen's Traits

I consider hydrogen to be a much safer fuel than gasoline or propane. Hydrogen has a built-in safety factor because it is the lightest element. Upon release it disperses very rapidly, rising straight up, and is lost as soon as it is released. Hydrogen disperses so quickly that a gas welding torch will not light unless the spark is next to the gas outlet. An ordinary acetylene welding torch can be used with hydrogen. The hydrogen flame is clear and to adjust the acetylene flame you will need to look at the glow coming from the metal. In bright daylight the hydrogen oxygen flame of an acetylene torch cannot be seen.

## Adjustments

A few simple adjustments can be made to your propane cooking stove to make it operate on hydrogen. Fill any large venturi cavity with steel wool to prevent a popping noise. Next adjust the jet size, regulate the pressure, and close off all air at the jet.

Gasoline engines can also be adjusted to run on hydrogen. I have adapted a propane/air mixer to a gasoline carburetor with success using hydrogen as a fuel. A standby gas generator set adapted to hydrogen would be a good arrangement.

A better use of hydrogen that I would like to see, rather than wasting it on a low efficiency gas motor, would be the use of a hydrogen-oxygen fuel cell. A fuel cell can be used for electricity or to run a vehicle with good efficiency.

## Storage

I store my hydrogen in a 500 gallon propane tank. Propane and hydrogen are compatible in the same tank. In fact, propane can be conserved by bubbling hydrogen into it. Another advantage to putting hydrogen in propane tanks is to add smell to it, and to avoid mixing your hydrogen with oxygen from the air. Propane tanks also

have a pressure release valve set at 250 PSI. I have had no problems with storing hydrogen below this pressure.

Hydrogen and oxygen must be stored in separate tanks. The only time to combine oxygen or air to hydrogen is at the burn site. Hydrogen and oxygen mixed and ignited is explosive, same as any hydrocarbon fuel.

## Electrolysis

In my electrolyzer cell, the hydrogen evolves off the negative potential; the positive potential releases the oxygen. It is important to maintain the same polarity on an electrolyzer cell. If the polarity is switched your gases will be mixed. I use Nickel on the positive side along with potassium hydroxide as an electrolyte. Nickel electrodes in potassium hydroxide do not electroplate away. Pure water is a non-conductor of electricity. Therefore, a potassium hydroxide electrolyte is necessary. The potassium hydroxide is not used up in the process of electrolysis. I purchase my potassium hydroxide from a chemical warehouse.

I use the hydrogen gas for combustion. I use the oxygen gas produced for welding, especially for cutting which uses lots of oxygen. I haven't bought oxygen for my cutting torch since I installed the hydrogen setup.

## Homemade Electrolytes

If you want to make your own electrolyte, it can be made from wood ashes. First, soak your wood ashes for a period of time, depending on how concentrated you want your solution. Remove the clear solution off the top of the wood ashes, then evaporate down to the specific gravity you want your electrolyte to be at. A weak solution works fine, and is not as caustic as a stronger solution.

## Gas Pressure

Hydrogen and oxygen gas will evolve from the electrolyzer under pressure. This can be taken advantage of by using a hydrostatic column to obtain



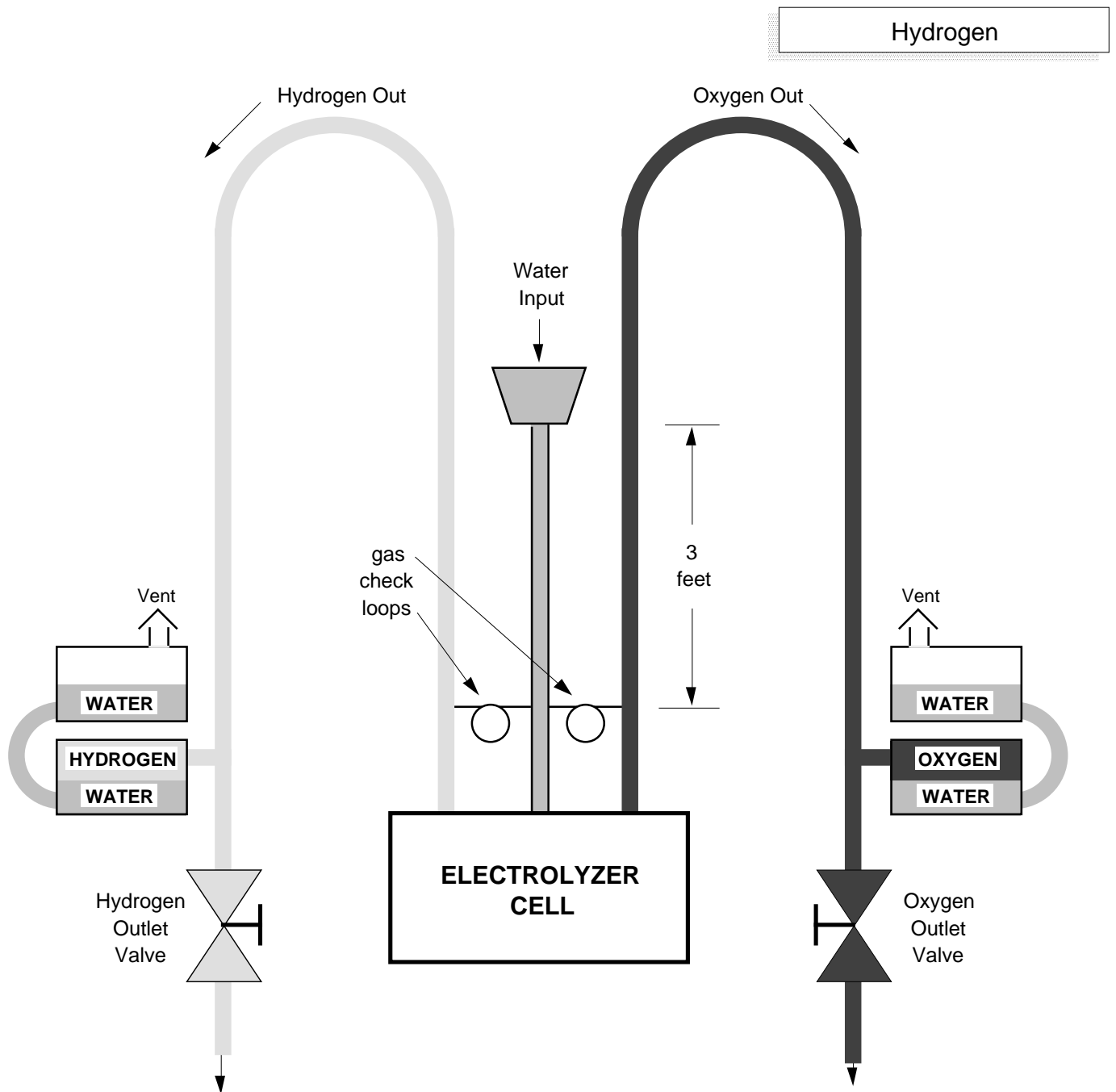

pressure. See the illustration. This one cell electrolyzer along with this simple three foot hydrostatic control will give pressurized storage of both hydrogen and oxygen with no moving parts. The pressure is obtained from the weight of the three foot water column. This is sufficient pressure to displace the water from the bottom 55 gallon barrel to the top barrel. The water in the top barrel in turn puts pressure on the gas. A series of 55 gal. drums can be lined up in this fashion to store larger quantities of gas.

There is no need for gauges as the liquid level can readily be seen through the clear tubing. There are no pop-off

valves to be concerned with. After adding the electrolyte to the system only water and electricity are needed for continued operation. A fail-safe feature of this control is that the hydrogen and oxygen go into storage or are vented into the air.

#### Controls & Power Sources

I also build a 50 PSI control that operates three electrolysis cells in series which operate at 12 Volts DC and 40 Amperes.

My larger control is a 100 PSI control which can handle six or more electrolyzer cells in series. I presently have a

## Hydrogen

six cell unit with a 100 PSI control in my shop. It is powered by a Jacobs wind generator. Each cell requires 4 Volts DC. These are wired in series and operate at 24 Volts DC and will load to 40 amps with each cell delivering 1/2 cubic foot of hydrogen per hour on a windy day.

A good power source to drive a one cell electrolyzer is a high amperage six Volt wind generator. Another good source would be a permanent magnet motor driven by water.

### Access

L.E. Spicer, Hydrogen Wind, Inc. RR#2 Box 262, Lineville, Iowa 50147 • 515-876-5665.



BERGEY  
WINDPOWER  
AD

## WATER ELECTROLYZER

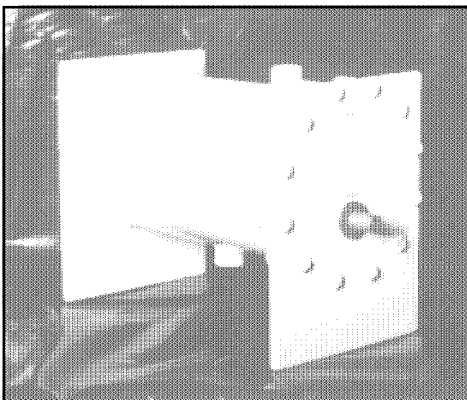

### Hydrogen and Oxygen from your Power Source.

\$125 plus shipping

Plans and Information \$1.

### Hydrogen Wind Inc.

Rt. 2, Box 262, Lineville, IA 50147  
515-876-5665

TRACE  
AD

# Renewable Energy Offers Freedom

Richard Perez

**W**hat are the advantages of making one's own power? Why do we use photovoltaic arrays to harness the Sun's energy? Why do we install microhydro turbines to turn falling water into electricity? Why do we use wind powered generators? What do we get for all our dollars and hard work? There must be a reason we are powering our homes and businesses with renewable energy. In a single word, renewable energy offers us freedom.

## The situation...

Power pundits, government agencies, ivory tower graybeards, and oil companies have been telling us for years that renewable energy sources are the "Power of the Future." Well, I'm telling you that renewables are the Power of Today. For thousands of us, renewable energy has powered many, many yesterdays.

Home Power Magazine is a hands-on, technical journal for those making their own power, or wanting better to use the power they rent from utilities. We focus on the actual application of renewable power sources- the get down and do it nitty-gritty of the matter. It's easy to focus on the hardware- the technical details, and neglect the reasons why we use these renewable sources. We have discovered intangible reasons, and in some cases, immeasurable, advantages of renewable power use.

No one is closer to the forefront of power technology than those who make their own electricity. Home power systems must make the most effective and appropriate use of what Nature offers. Energy agencies and utilities are constantly conducting megabuck experiments to determine what is possible. Meanwhile, people are living on their own home-made power and doing it with minuscule budgets.

Home power producers are learning more, faster, than anyone else ever has because they are living with renewable power systems on a daily basis. To accomplish this on a budget, we have married new power technologies with efficient and appropriate power use. We are not inventing new things, but we are successfully combining many technologies and ideas for the very first time.

Here are some of the freedoms of living with what nature freely provides. Some of these freedoms are for the users of the system alone, and some are for the entire world.

## Freedom to live where we want

The best deals in American real estate are beyond the commercial power grid. Country land, beyond the power lines, costs far less than property with commercial electric access. These properties cost less because everyone agrees that no utility access is a major disadvantage. Home power users have turned this common misconception to their advantage. Using renewable energy sources has allowed us to live on pristine, inexpensive, and remote land. We simply make our electricity on site. We use natural power sources like sunlight, flowing water, and wind.

A renewable energy system for an efficient household of four people costs less than two thousand feet of new power line. For this reason alone, many of us decided to make our own electric power. Here on Agate Flat, the Home Power office is located eight miles from the nearest commercial power access. In most areas of the U.S., utilities charge between \$5.00 and \$15.00 per foot for newly installed power service. Our local utility is charging \$5.35 per running foot for new lines. This adds up to a \$225,000 initial line installation cost and a minimum \$50 monthly electric bill. It's easy to see why we choose to use photovoltaic power- it saved us \$215,000 the day we installed it. Our PV system continues to save us money every day because it has no operating expenses.

America's electric power utilities are not interested in extending their already extensive and overburdened distribution network for small, remote groups. The best way to understand this situation is to examine what it costs the utilities to operate. Look at where power companies spend their money. Nationwide, the utilities spend about 45% on power transmission and power line maintenance, about 24% on actually generating the power (this includes building the power plants), and about

## Why use renewable energy?

30% on everything else. They are not into extending power lines for small-time consumers because it costs the utility more than it earns.

So, the best land sits undisturbed and unwanted because it lacks access to commercial electricity. For home power users, this land is the stuff dreams are meticulously made of. Most of this land is pristine— never before inhabited by Western Man. If it had been inhabited before, it would have electricity, right? As long as Americans don't realize that they can live wherever they want, then there are fantastic deals to be had in rural land.

So, making our own electricity gives us freedom to live in places thought to be uninhabitable. Making our own electricity gives us easy access to pristine rural property at rock bottom prices.

### **Freedom of reliable electric power**

Renewable energy systems, particularly those which use photovoltaics, produce the most reliable electric power ever known. PVs have the longest life of any electric power source ever developed. They require no maintenance. They have no moving parts to wear out. They require no lubrication or adjustment. All they need to produce electricity is sunshine. The useful lifetime of currently made PV modules are on the order of scores of years, and may well extend to over one hundred years. Photovoltaics are power we can give to our children.

While wind and hydro powered sources are not as reliable as photovoltaics, they are much more reliable than electric power shipped to a site by wires. As the web of utility lines crossed the nation, the transmission system has become more complex and vulnerable to overloads, human errors, and weather. To appreciate the fragility of the grid, consider the 1965 blackout that plunged the entire eastern seaboard of the U.S. into darkness.

The utility grid's size, interconnection, and complexity makes it vulnerable to brownouts and blackouts. As the size of any system grows, the laws of probability and physics render it less reliable. The tiny renewable energy system is simple and not connected to anything but itself. Distributed, small systems are inherently more reliable than one big system.

The batteries used in renewable energy systems have a finite lifetime of between ten and fifty years. Batteries are the weakest link in these systems. However, during their effective lifetime, they deliver extremely reliable power storage. This is why batteries are used for uninterruptible power at utility substations, hospitals, police, airports,

computer installations, military bases, telephone companies, railways, & telecommunications installations. All of these essential services cannot tolerate even momentary loss of electric power. Home power users also get this degree of reliability.

### **Freedom of economic self-sufficiency**

In almost all renewable energy systems, all the power is produced and consumed on site. These systems are isolated universes of electricity, each a discrete energy entity. The power output of the system goes to only one place, the people using the system. These are the very same folks that own and maintain the system. We have our own power company. While it may be a very small power company, it's all ours. We bought it and now we have it all to ourselves.

This home power company uses natural energy sources, so it has no fuel costs as the nuclear, oil, or coal power plants employed by the utilities. The home power system is truly self-sufficient because we have paid for our electricity in advance when we installed the system. After the system is installed, it produces power without demanding monthly bills from us.

All we have to do is buy the system. After that, we are free of ongoing power bills. Utility rates continually increase. Our income may be diminished by fortune, job changes, health, age, and/or inflation, but all these financial setbacks do not effect our already installed system. We got it together once, did it, and now it's ours.

Renewable energy systems offer financial security by giving us a fixed cost for our electricity. The system provides additional security because we pay for the system up front. We buy the power company once, at a fixed cost, instead of renting it by the month at continuously increasing rates.

The economic freedom of a renewable energy system is roughly equivalent to growing your own food versus buying it from the supermarket.

### **Freedom of a clean environment**

Electricity produced from renewable energy sources has the lowest environment damage of any type of power. Photovoltaics produce no pollution basking quietly in the sunshine. Wind machines don't foul the atmosphere, or the water or the earth around them. Microhydro systems don't require damming their water sources, but merely borrow some of the water and then return it, unharmed, to its stream.

Renewable energy sources are environmentally sound

because they use what Nature is already offering us. Renewable energy works with the environment without stressing our ecosystem to the point of collapse and death.

Coal fired power plants belch tons of sulfur dioxide into our atmosphere yearly. This sulfur dioxide eventually falls back to earth as the acid rain that is killing our lakes and forests. Oil fired power plants produce tons of carbon dioxide, carbon monoxide, and nitrous oxide. All these emissions contribute to the Greenhouse Effect that is turning our planet into a desert. Nuclear power plants produce tons of highly radioactive waste. No one even has a clue of how to dispose safely of radioactive waste. Compared to the pollution produced by conventional power sources, renewable energy offer us a planet that is livable and sustainable.

This is possibly the greatest benefit of solar, wind and microhydro power. They are something we can live with, whereas other energy sources ask us to flirt with planet-wide destruction.

#### **Freedom from war and other political nastiness**

Regardless of what one may think of the recent war in the Persian Gulf, we can all agree that oil fueled this suffering. Without oil money, Saddam Hussein and his bully-boys would have been herding goats, not raining missiles on

their neighbors. Using nonrenewable power sources places tremendous economic, political, and military power in the hands of the few who own the oil and the coal. Historically speaking, this type of concentrated wealth and political power has always brought out the worst in us.

The power and wealth of renewable energy are freely and equally offered to each of us. No one holds a monopoly on sunshine, or blowing wind, or water freely flowing. These power sources cannot be owned and are naturally and democratically given to all of us. Nature gives us more energy than we can possibly use. Renewable power sources are a way of graciously accepting this gift.

#### **Freedom**

There are many more freedoms than I have listed here. Every home power user can add a few more to this list. This is why we are making our own power. This is what we have learned. One of the strangest things we have learned is that freedom is synergistic. Many specific freedoms add to a big freedom that is greater than sum of its parts. I encourage you to add a new freedom to your life, and thereby to all our lives.

#### **Access**

Richard Perez, C/O Home Power, POB 130, Hornbrook, CA 96044 • 916-475-3179.



Backwoods  
Solar  
AD

# Gettin' into Hot Water

Bill Battagin

©1991 Bill Battagin

**T**here's been a lot of talk about hot water lately. Generally, to our gang, that means doing it with something other than gas or electricity (e.g. sunshine). For those who thought they've seen it all, here's another wild, yet simple, idea that may get you into hot water.

## Closed-loop Thermosyphon

I call this system a closed-loop thermosyphon. Thermosyphon systems are not the highest in overall efficiency. They do offer many advantages to the home builder. They are simple to make and don't require electric pumps. Home builders can use tricks to gain an edge in efficiency.

A thermosyphon system is as follows: the solar hot water panel(s) is located on a lower story, porch, or shed roof so that the TOP of the panel is at least 18 inches below the bottom of the storage tank. Tank location is usually in a second story, an attic, sometimes a cupola - somewhere that ensures an 18 inches vertical height difference between panel and the tank. Systems where the top of the panel is above the bottom of the tank will work if installed properly, but is generally not recommended.

## A Heat Exchanger

The key to this system is the heat exchanger, the only element in the system which must be "homegrown". Why use a heat exchanger? Mainly use it because it provides freeze protection. Even if the possibility of freezing seems remote, you need to take this precaution! It only takes one frozen night to ruin an unprotected collector. The heat exchanger also increases the efficiency of heat transfer. Finally, antifreeze is not as corrosive as water. The heat exchanger in my systems have been: 4 inch steel pipe inserted length-wise through a non-glass lined standard electric hot water heater tank (older variety); or capping and welding couplings to the ends of what is now the flue of a gas hot water heater.

The tank should have a minimum of 40 gallons storage because solar heaters don't "kick-on" when the demand is high. Of course, the more people using the hot water, the larger the storage should be. I build 85 gallon tanks for a family of 4 careful users. Most of the systems I've installed were with a tank/heat exchanger that I've built from scratch, then had hot dip galvanized. So, the

simplest scenario of this system is solar heated antifreeze from your panel rises (thermosyphon) to the heat exchanger in your tank. Losing its heat and thus becoming more dense, the antifreeze sinks back to the panel to be reheated.

## Heat Exchanger Details

I feel like apologizing for the system being so simple, but thermosyphon systems are simple. Some of the details are critical, however, and need discussion and careful attention. This heat exchanger does not employ a double wall between the heat exchange fluid and your potable water. Technically, this is unacceptable, due to the possibility that a leak could occur in this one wall and a toxic fluid could mix with your hot water.

In the real world, (1) Don't use a toxic fluid. Propylene Glycol is non-toxic to humans. (2) How many of us drink water from the water heater? (3) Install a pressure gauge in your solar loop and charge the loop to 25 psi. or lower than your domestic water pressure. Most water supplies will be considerably higher than 25 psi, so if a leak occurs rather than your glycol and water mixture flowing into your potable water, water flows into the glycol and water mix. At this time, your pressure gauge tells you that there is trouble, and repairs can be made. The likelihood of a leak is slight if (a) schedule 40 galvanized steel pipe or, (b) an exterior glass-lined flue in a gas heater are used as the heat exchanger. In one case we have zinc, in the other case glass, protecting the steel from corrosion. The zinc coating on the INside of your galvanized pipe will have to be removed before you're finished. Zinc is not compatible with propylene glycol.

Zinc removal can be accomplished with one gallon of "pool acid" (20% hydrochloric or Muriatic acid) diluted with two gallons of water. Pour this solution carefully into your completed heat exchanger with the bottom coupling plugged. Take your time, have a hose nearby, wear appropriate safety clothing as the zinc/acid reaction is pretty exciting at first. It might take an hour of small,

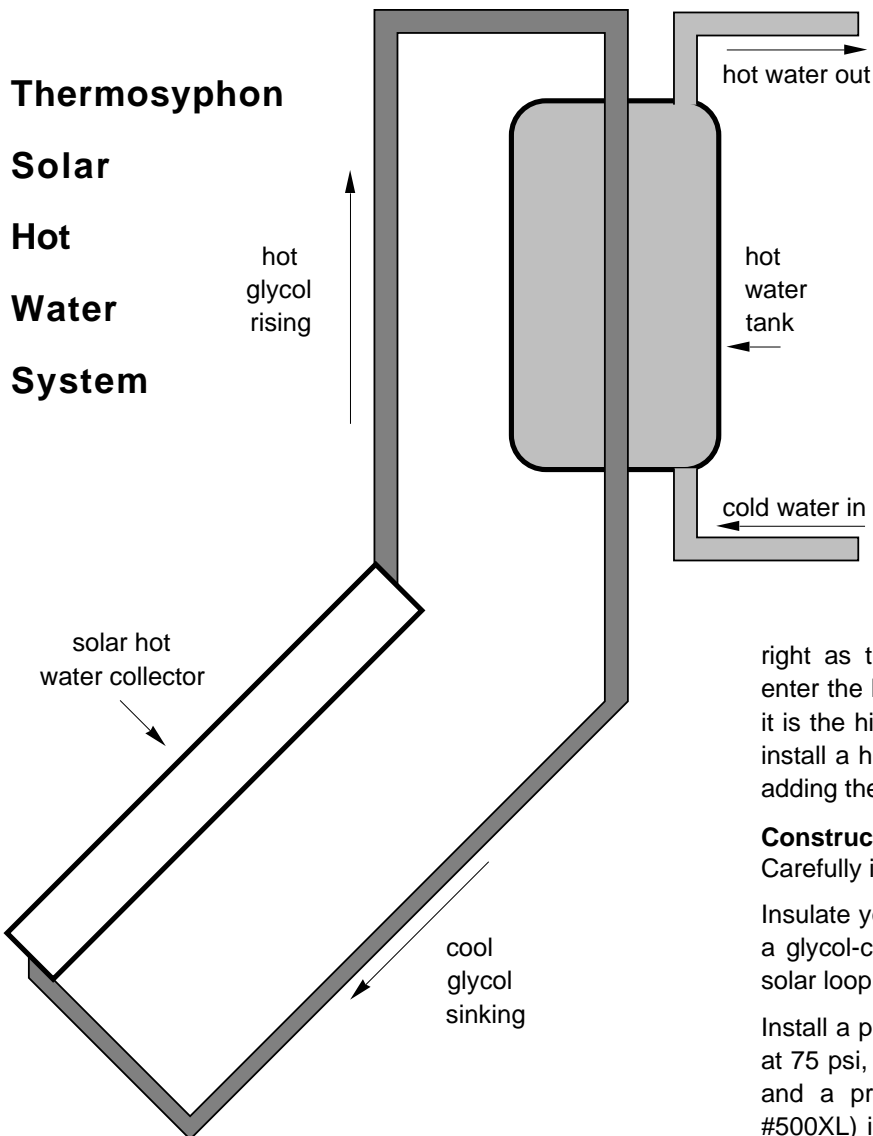

## Thermosyphon Solar Hot Water System

the panel with the long edge parallel to the roof's edge (horizontally), which is that this will get the "top" of the panel lower with respect to the bottom of the tank. If you can mount the panel with the short edge parallel to the roof's edge and still have good vertical height difference, do it. The panel must be of the header/riser type so any air in the panel can get out, which leads to...

### Airpockets

In any thermosyphon system, great care must be taken to insure that all components and pipes are installed so that air anywhere in the system can get out. Air heads grasp this concept quicker than the average tofu-eater, but all systems must inevitably live by this law. Install a vent

right as the heated glycol and water mix are about to enter the heat exchanger. This is the best place because it is the highest point in the loop. This is a good place to install a hose bib for cleaning and rinsing the loop before adding the glycol and water mix.

### Construction Details

Carefully insulate your solar loop pipes - Yes, it matters.

Insulate your tank with AT LEAST R-19 fiberglass. Install a glycol-compatible expansion tank below the top of the solar loop.

Install a pressure only relief valve (Watts model #530) set at 75 psi, in the solar loop towards the top of the hot run; and a pressure/temperature relief valve (Watts model #500XL) in the top of your hot water tank. These valves and a pipe from the drip tray under your hot water tank should all be run to a visible outside location - label them where you see them terminate.

When you connect the copper pipes from the panel to the heat exchanger you will have to use a few galvanized parts and a dielectric union. This little bit of zinc exposure to the glycol and water mix is not enough to cause problems. If you've used an electric water heater tank, connect the juice (if available) for back-up to the solar (its proper place, in a world of sunshine!). Heck, don't be shy, hook-up the wood stove first - forget the grid!

Install a hose bib to a point just below the lower connection to the panel and don't forget an easy to read pressure gauge somewhere in your solar loop.

### The Final Stretch

Lastly, we need to clean and Charge! the solar loop.

intermittent additions of acid to get the heat exchanger full due to the bubbly reaction. Once full, let the reaction continue for about 30 minutes, then drain, neutralize (use baking soda) and dispose of the acid properly - FLUSH THOROUGHLY. If the heat exchanger is not yet welded into the tank, do so now. Check for leaks, and the hard part is over.

### Panel Discussion

I favor factory built panels because of durability. Homegrown panels are great because you can scrounge parts. However, you must take the time to do a meticulous job if you want the panel to stay effective over time. Mounting the panel with either the long side or the narrow side parallel to the roof's edge is acceptable. I'm not going to discuss panel tilt here - there's plenty of info out there on it. There can be an advantage to mounting

## Solar Hot Water

You'll need another recycled 30-40 gallon hot water heater tank (the Charging! tank). In your own creative way, thoroughly clean and rinse this tank. Then connect a hose bib to the lowest opening, install an air stem in any top location (to add compressed air), and install a 0 to 100 psi pressure gauge. Plug all other openings except one. With a funnel, add approximately 6-7 gallons of a solution of trisodium phosphate and water, then plug this hole and pressurize the tank to 70-80 psi. Connect the hose bib on this tank to the hose bib on the low side of your panel with hose and appropriate adapters. Allow the trisodium phosphate solution into the solar loop with the aid of the pressure in your Charging! tank - 30 psi into the loop is plenty. Check the solar loop thoroughly for leaks and for its ability to thermosyphon.

There should be hot water in your hot water tank for this step so you can feel a dramatic (20°F- 50°F) temperature difference between the pipes entering and leaving the heat exchanger. Allow to thermosyphon for 1-2 hours, drain, then flush with gobs (technical term for "lots") of water. Drain and flush the Charging! tank also. When draining the solar loop, catch the solution in a bucket so that the amount of glycol and water mix necessary can be determined. Take this amount and add a gallon for the total mix you'll need. OK, we know the system thermosyphons, it doesn't leak and it's clean. Pour the glycol and water mixture (mixed based on your calculations for your area - discuss this with the source from which you obtained the glycol) into your clean Charging! tank. Pressuring the tank to 70 to 80 psi, connect to the lower hose bib on solar loop, again and Charge! to 25 psi. Check for leaks and enjoy the next 50 years of solar hot water.

### Maintenance

- (1) Watch the pressure gauge on your solar loop. Under normal conditions, it will slightly rise and fall with the system's temperature. If it rises and falls with the pressure of your water supply, there's a leak in your heat exchanger.
- (2) In five years, you'll need to test the inhibitors and freeze protection of your propylene glycol. Addition of inhibitors or replacement of glycol may be necessary - again, your supplier can help.
- (3) Clean the covering on your panel (not when it's hot) occasionally if the rain hasn't been doing it for you.

**P.S.** This article puts me/my ideas on the chopping block for discussion and criticism, which I welcome. My intentions in writing this article were to help heal this planet that has given so much. No hot water system is environmentally benign, but to my knowledge, this system

is comparatively low in impact and is durable.

### Access

Author: Bill Battagin, who freely admits to being an airhead and a tofu-eater, can be reached at: Star Route, Tayorsville, CA 95983 • 916-284-7849.



### PRODUCT UPDATE CC-60B and CC-120B 45, 60, 90, 120 Amp Charge Controller

The Hi-Eta line of "Series Type" charge controller is the most reliable, versatile, and maintenance free photovoltaic controller available today. The "Series Type" of charge control does not use failure prone relays or other electromechanical parts. The entire line of Hi-Eta controls employs the MOS FET power technology because the life expectancy is not decreased by frequent on/off switching as with a relay. Reliability is what systems require most and is what allows our exclusive 10 year warranty protection on all of our Hi-Eta products.

A new digital display readout on the front cover is now available on the CC-60B and CC-120B for reading the array voltage, the battery voltage and the charging current. The models with the digital display are designated with a DPM suffix. For more information on this frequently requested feature or on any on the Hi-Eta products contact your local distributor or call the factory direct.

Heliotrope General  
3733 Kenora Drive  
Spring Valley, CA 91977  
800-854-2674  
800-552-8838 (In CA)



*Serving the Solar Industry for over 17 Years*

**Skyline  
Engineering**



# Rack Hacking

John Drake

©1991 John Drake

**T**his is about PV support structures, fasteners and assembly. You see little in print about these subjects. This is a shame because when support structures fail they can, at best, cause physical damage to the system. At the worst, it may result in bodily injury.

## Support Structures

Considering the investment in time and money involved in setting up a photovoltaic array, attention should be given to "the little things" that determine long term success or failure.

The most common metals available in descending order of effectiveness are: stainless steel, aluminum, galvanized steel, structural, and mild steel.

## Stainless Steel

Stainless steel is the king of materials in most environmental situations. On exposure to the air it forms a tenacious chromium oxide layer which gives it its stain-less qualities. Please remember, it is called stainless steel, not stainproof steel. The easiest way to corrode stainless is to clean it with a regular wire brush or steel wool.

By doing so, you introduce iron into the surface. Many stainless steels have little or no iron content. For most people stainless steel is difficult to work with and join properly. For drilling into stainless steel it is best to use low speeds, a cobalt bit and plenty of cutting fluid. On the plus side, stainless (e.g. type 304) will last as long as you need. It may even aid in the resale value of an AE system. This is because most people equate stainless steel with permanent non-maintenance.

## Aluminum

Aluminum is most commonly used in commercially available structures. These are usually anodized, which is an intensive conversion at the surface to aluminum oxide (same material as in most grinding wheels) in an electrolytic process. Unfortunately they are often much too light (member thickness and shape) for the intended use. Aluminum, as a rule, is stronger than steel by weight, but not by volume. It is easy to cut and drill non-hardened aluminum, but any break in the coating should be sealed. There are user-applied coatings available from industrial coating and paint suppliers.

Except in a pristine environment, don't use bare aluminum. I have handled 1/4" and 5/16" thick aluminum sections which have been exposed to the elements in Southern California for one to three years. These samples had the strength of a soda cracker and crumbled (flaked) just as easily.

If you choose to use un-anodized aluminum, especially near salt water, I suggest a marine grade of the 5000 or 6000 series alloys. High levels of air pollution or acid rain can also degrade the integrity of aluminum structural members. As a rule most anodized coatings are effective within an environmental ph range of 4 through 9.

## Galvanized Steel

Galvanized steel is a good choice if you are not near salt water or in a high pollution area. The coating, usually a zinc alloy, sacrifices itself to the steel member. In a mild environment it can last for years. Many people use slotted galvanized angle for frames. These are available from many local sources. This is fine if you are in a fairly benign environment and avoid contact with active soil.

## Structural or Mild Steel

Structural or mild steel would be my last choice because, in most cases, they offer little corrosion resistance as received from the mill. The presence of mill scale can accelerate the degradation in use. You can paint them, but this will be an on-going project. Steels are very susceptible to corrosion damage because the oxides that form on the surface do not bond to the metal underneath.

They continually flake off and expose fresh metal to the elements. When a structure is designed using exposed structural steel members, the yearly rate of material loss is taken into account to determine the life span and maintenance schedule of the finished project. If you choose these metals, clean the members as much as possible without polishing. Use a good quality metal primer before using a high quality paint formulated for steel.

### Corrosion Protection

When handling any coated metals: Set the components together, do not (when possible) slide them together. This can scratch the coating, thereby opening the door to corrosion. Corrosion can be caused by oxidation - metal mixing with the oxygen in the air. It can also be galvanic in nature - moisture infiltration between faying (touching) surfaces sets up an electrical (like a cell) potential which transfer metallic ions from one to the other. This is why pipelines use a cathodic protection by burying a sacrificial anode nearby. The anode transfers to the pipe instead of the pipe transferring to minerals in the soil. Boats also use similar techniques for protection. Most corrosion that we are familiar with causes a de-alloying which removes alloys from the member (like removing water from a sponge) which can not be seen. Stress corrosion cracking may also occur when cracks appear at sites attacked by corrosion.

A less noble metal will sacrifice itself to a more noble one. Zinc plating (galvanizing) will sacrifice itself to steel. The heavier the coating, either dip or electroplating, the longer the steel will last. Eventually the coating will fail and substrate (in this case the protected metal) will follow. One should note that these coatings go into the environment. Cadmium, a very popular plating material, is also a nasty heavy metal. Bones readily absorb this and other heavy metals. Many steels contain lead to give the alloy its desirable properties. In the near future you should see many coatings and surface alloying methods which are less harmful to our planet. The assembly of aluminum to conventional steels should be avoided. The aluminum will sacrifice itself to uncoated and some coated steels. If you must put aluminum in contact with steel it is a good idea to use an inert insulator.

### GALVANIC SERIES

These metals are arranged by their tendency to corrode galvanically;

#### Corroded end (anodic)

Magnesium  
 Magnesium alloys  
 Zinc  
 Aluminum 1100  
 Cadmium  
 Aluminum 2017  
 Steel or iron  
 Cast iron  
 Chromium-iron (active)  
 Ni-Resist  
 18-8 Chromium-nickel-iron (active)  
 18-8-3 Chromium-nickel-molybdenum-iron (active)  
 Lead-tin solders  
 Lead  
 Tin  
 Nickel (active)  
 Inconel (active)  
 Hastelloy C (active)  
 Brass  
 Copper  
 Bronzes  
 Copper-nickel alloys  
 Monel  
 Silver solder  
 Nickel (passive)  
 Inconel (passive)  
 Chromium-iron (passive)  
 18-8 chromium-nickel-iron (passive)  
 18-8-3 chromium-nickel-molybdenum-iron (passive)  
 Hastelloy C (passive)  
 Silver  
 Graphite  
 Gold  
 Platinum

#### Protected end (cathodic)

### Fasteners

My advice is, if it is not stainless steel, do not use it. Do not mix stainless and non-stainless steel fasteners together. When purchasing stainless fasteners your best bet is to buy from a fastener distributor.

Hardware stores and marine supply centers will usually charge more (sometimes they have to), not have the item in stock or know nothing about it. I have been told that stainless steel lag screws do not exist. Our arrays are mounted with these non-existent lag screws. If in doubt as to whether a fastener is stainless, check it with a magnet. Except for some 400 series stainless, a magnet is not attracted to stainless steel. When purchasing stainless fasteners for some of my fabrication work and save up to 60%, by purchasing them by box lots, over the single unit price.

### Assembly

The most common structural shape you will encounter is the angle. You should always place the horizontal leg on top. If you do not, the member will lose over half of its load carrying potential.

To me, the best way to join something is to weld it. This is not always possible. In cases where it is, please follow some guidelines. If you are not positive you will do it right - find someone who will. I have seen welding on mild and structural steel, let alone stainless steel and aluminum, that is an accident waiting to happen.

If you are mounting an array onto an existing structure (like a tower) you can damage the structure itself if not careful. If in doubt, use graded (hardened) fasteners instead. When drilling any hole for a fastener, drill the smallest hole possible. This will minimize corrosion sites, reduce material loss degradation and member movement. When welding, remove all rusts or

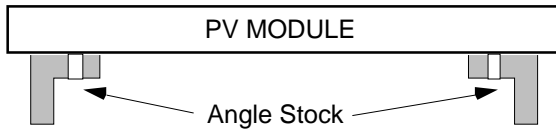

oxides. Keep gaps small and make sure all welds are full penetration and are thoroughly cleaned when finished. On stainless steel in salt environments I would recommend filler metals with the letter "L" (low carbon) following the alloy number.

**Roof Mounting**

For roof mounting, one option is to mount the frame pads (feet) to 2"x6" treated lumber. This will spread the weight over as many rafters as possible. You may choose to bolt through to a back-up board, using oversize washers, to prevent pull through. If you lag into the rafters themselves, unless they are oversize, you may appreciably weaken them. When using lag screws, drill the proper pilot and size holes to maintain grip and retain the lumber's strength.

**Ground Installations**

For ground installations it is best to use a concrete pad or pillars. When pouring concrete you should keep in mind that you want water to run away from the ground mounting pads. The most readily available mounts for wet concrete would be "el" shaped anchor bolts. For existing concrete you may use either lead shielded anchors (with lag screws) or the "red devil" type. With the "red devil" types you can drill and insert the anchors through the mounting pads in place.

Whenever possible, plug any unused holes, especially in vertical sides, with snug fitting fasteners. This will reduce the possibility of failure at these weakened sites. It is common practice to do this on the frame rails of large trucks.

**Structure Stress**

You need to be concerned with two types of stresses your structure will face. The first is static load: the constant pull of gravity on the frame, modules and wiring. The second is dynamic load: momentary forces applied to the structure; wind, storms, earthquakes and the neighbor's kids. If you ask your self how nature would defeat your structure then you will have better insight into preventing this. Site location can also aid in the array's mechanical longevity. Use a good base and, if possible, locate it out of harm's way (people as well as nature can be indiscriminate).

**In Conclusion**

If you give as much attention to the mechanical facets of your system as the electrical ones, you may prevent failures down the road. If a system fails mechanically, the uninformed public may view it as a failure of solar energy in general. When we step over a dollar to pick up a dime - none of us can complain about being short changed.

**Access**

John Drake, (213) 423-4879

List of Galvanic series is from the Metals Handbook - Desk Editor, by the American Society for Metals (now the ASM International)



***John Drake Services, Inc.***  
**Metal Fabrication & Arc Welding**  
**Commercial / Industrial Photography**  
**Solar Electricity Sales**  
**Long Beach, California**

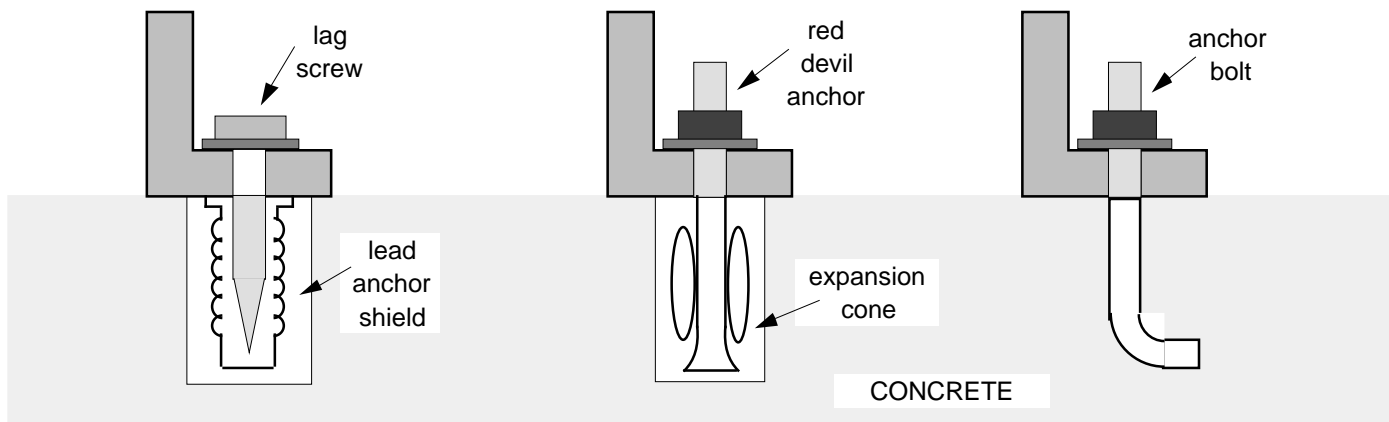

# Slaying a Watt-Guzzler— Washing Machines

Jim Forgette

©1991 James F. Forgette

**C**onventional ac powered washing machines, plugged into a large inverter, seem to be the way many home power folks are doing the wash. But is this method the most efficient, or is it just another case of "watt-guzzling"? Another way to power these washing machines exists that consumes FAR LESS electricity – two, three, even four times less. These full-size washing machines are one of the big consumers of home power electricity. Three washes for the price of one saves a lot of electricity– watts that needn't be "thrown out with the wash water".

## Striving for Energy-Efficiency Pays Off

I consider myself an old techie, but the deeper meaning and global importance of efficient energy use recently came over me in a new way (Thanks HP mag!). I began to look at my entire home power electrical system in a new, inquisitive way. For example, I calculated that I had unknowingly been shoveling about four times more electricity into my old lead-acid batteries than I took out. I realized that my two 60 watt PVs were not keeping up with the batteries' self-discharge, let alone providing my home any electricity. What an incredible waste! Part of the "lead-acid experience", as its been called. So instead of buying more PVs the next time finances allowed, I first got different batteries that weren't "bottomless pits". I bought some good, used Nicads, advertised as, and

indeed, very energy efficient... The improvement is profound. A smaller example is the "always-on" light in our dining/den/study room. I replaced the tungsten light with one PL fluorescent, same brightness yet three times less power use. These and other changes reduced the amount of electricity we needed to produce, and we had more electricity to actually use. That's what gaining energy efficiency is all about.

## What About Washing Machine/Large Inverter?

Many home power folks aspire to, but stop short of, home powered clothes washing. You need sufficient generating capacity, whether PV, hydro, wind, fossil fuel, etc... You must buy extra battery capacity and shell out \$1,000+ for a large inverter. Then, finally, you can run your standard ac powered washing machine on your system. For sure, it's a big step forward in independence and convenience. For my household, we usually washed four or more loads per week. The washer/large inverter combo was the BIGGEST single consumer of our home made electricity. From my view as home "powerplant manager", the washer was THE WASHER, the most stressful load on my inverter and batteries. I figured, if that's what it takes, then that's what it takes, so I grudgingly fed the beast. It did seem a shame though, to be spending so much electricity on just "doing laundry".

## The Investigation

My energy efficiency thoughts kept coming back to the washing machine. Maybe there was a way to make it consume less electricity. But first, I needed to know more about what I was dealing with. By actual measurement, my full-size automatic washer consumed about 1,000 watts of power for every thirty minute wash, which is average for most full-size washers. For comparison, this is like turning on seven 15 watt fluorescent lights for four hours, or operating a typical 13" color TV & VCR for five

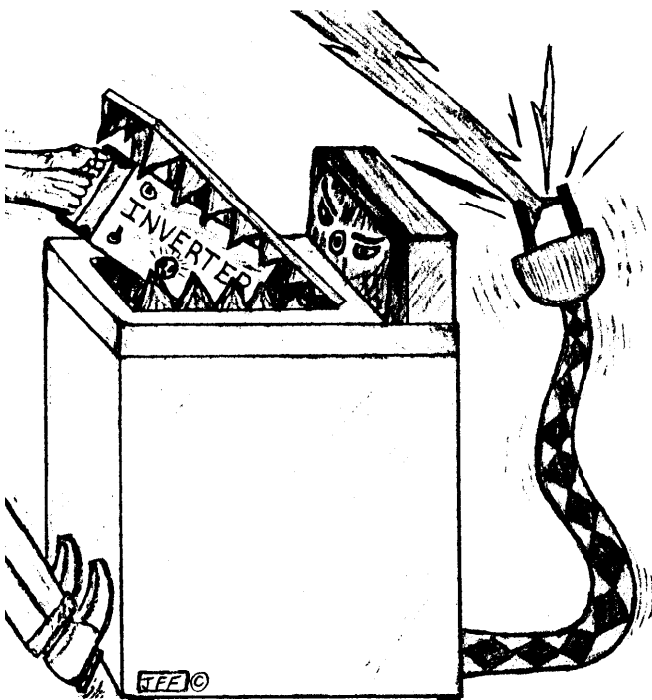

hours. To produce this much electricity (including inefficiencies), would take one sun-day and two 50 watt PV panels. This represents just one load washed.

### Heavy Watt-Guzzling Exposed

I wanted to find out how energy-efficient that electric motor was...how much actual work did it give me for those 1,000 watts of power? Through measurement and calculation, I determined that my washer motor was about 40% efficient. Not very good, but typical of mainstream washing machines. I knew that affordable, higher efficiency electric motors existed. Why didn't these appliance-makers use them? Clue: cheapo motors means bigger profits. This was beginning to look like a classic case of "watt-guzzling". I felt increasing determination to install a more efficient electric motor in my washing machine...ASAP!

### A More Efficient Alternative?

Before we could afford a large inverter, I had often dreamed of running the washing machine on DC. There is a little booklet (Convert your washer to 12 Volts), in print for years, that explains converting certain kinds of ac powered washers to DC. There are even DC conversion kits on the market. Washers converted to DC are promoted as a way to get around a large inverter. I already had a large inverter, bought mainly to run a washing machine, and I had put DC washers out of my head. I hadn't thought of the efficiency of DC motors as a prime consideration. Good quality "permanent magnet" type DC motors are very energy efficient.

### The "ac-Only" Crowd

In talking with other off-grid folks, some frowned at the mention of DC stating that their home was wired for 120 vac only. This is no problem because these efficient DC motors also come in higher voltage versions and, with a rectifier and capacitor circuit, can be powered by standard ac electricity, either grid or inverter produced. Just plug the washer in. The rectifier would add a little efficiency-loss, but the washing machine would still only use half (or less) the electricity as before. Shows you how grossly inefficient the stock ac electric motor really is!

### The DC and ac/DC Gang

Many of us off-gridders have wired our homes for DC only or a combination ac/DC system. We could run a washing machine on straight DC, be it 12, 24 or higher voltages. No large inverter is required. My early experiments show that the washer would only consume 1/3 the electricity. These straight DC versions do have a few quirks to deal with. First, the wire size between the washer and batteries must usually be bigger than regular, Romex-type

house wire. How much bigger depends on the distance between the appliance and batteries. Secondly, a small inverter is required for automatic washers in order to run the washer's ac timer and other internal controls. A good quality, small 100 watt inverter costs about \$150. Far less than a large one. If you're a DC purist, then consider the inverter as part of the washer's internal components.

### In Other Words

This DC motor conversion could be adapted to either low voltage DC or 115 vac home power systems. The only restriction is that some washing machine designs are NOT easy to convert.

### The Test

CAUTION: you should either be a techie or have good instructions if you want to experiment with your washer's innards. I had the right size energy-efficient DC electric motor, the inverter, and was willing to install a larger 12 volt house wire circuit to the washer. I was game to try the DC motor in my washing machine and see if I could "Slay the Watt-Guzzler". Not wanting to disable our home's washer to experiment, I used an extra spare-parts washer of the same kind for testing. Hooking everything up temporarily, I threw in a load of shop rags and let 'er fly. The washer began washing, but way too fast. Funny to watch, but not good for clothes or washer. A few fan-belt and pulley changes later, I finally got down to measuring power consumption.

### The Results

To my delight, the DC motor/small inverter team was consuming only about 300 watts (25 Amps at 12VDC)! The same kind of washer with ac motor/large inverter combo consumed 1,000 watts. I couldn't believe it at first. It was too good to be true, but it was true. It meant that if I used this DC motor instead of the stock ac motor, we could wash three loads of clothes for the same amount of power that one load used to consume. "Looking Good!"

My converted washer started life as a Ward's Signature model. It holds twenty pounds of funky laundry. I used an 1800 rpm, 1/2 hp Scott 24 VDC motor. Since this Ward's design reverses the direction of the motor, I used two heavy duty solenoids to switch the polarity of the motor. The solenoids I used are made by Stancor and are SPDT 50 Ampere models (types 70 and 1240). The round trip wire distance between the washer and my 12 Volt battery is 120 feet. I used recycled 0000 gauge aluminium cable to connect the battery to the washer. I changed the drive and driven pulleys which increased the efficiency even more. The use of a 1200 rpm motor and a larger drive pulley can boost efficiency.

**Why Am I So Jazzed?**

Why do I get so stoked about something as mundane as an energy-efficient washing machine? I'd rather see my hard-won electricity going toward something a bit more evolved than doing laundry. I can now use the extra power for other appliances or simply to gain more days of battery storage.

On a larger, national scale, much has been written about the serious need for more energy-efficient appliances. Lighting and refrigeration are getting most of the spotlight. The common washing machine is also a widely used major appliance. When I think of my now discarded ac motor and imagine it multiplied by all of the ac washers in the world, I realize that many large powerplants are unnecessarily feeding these watt-hogs. The same tale of guzzling is true for virtually all mainstream ac motor driven appliances. It's a crime...Hey Congress, here's a chance to EARN some of that \$100,000+ salary. Let's see a REAL Energy Policy, one with cornerstone emphasis on sustainability and the well-being of future generations.

**Making The Change "for Keeps"**

I first installed a new circuit between the batteries and washer, including a fuse or circuit breaker. ALWAYS, Always, always, include these safety features in you home wiring. No matter how destitute or in a hurry you may be. You don't want a house fire or worse.

I couldn't wait to get my hands on that watt-sucking ac motor. It took some experimentation and time to decide on, gather, and mount everything "for keeps". A week

went by before I was finished while dirty laundry kept piling up. When the conversion was complete, the washer got a real workout chewing on that mound of laundry. The washer ran "just like downtown". I felt proud and thrilled every time I looked at the meters and calculated. Only 1/3 the consumption as before. Alright!! Just to gloat for awhile, I set the old ac motor outside my shop door so I could growl at it as I passed by.

**Conversion Difficulty vs. Brand of Washing Machine**

The easiest washers to convert are the Whirlpool models made before 1985. These same models were also sold by Sears under the Kenmore brand. This type uses an easy to replace motor that runs in one direction. The motor is coupled to the washer's mechanism by pulleys and a belt. There are thousand of these washers available used & working, or in various states of disrepair. All wringer washers are old enough to use belts and pulleys and they are easy to convert to an efficient motor.

Somewhat more complicated to convert are the Wards Signature (LNC) models, like the one I converted. Since the motor reverses its direction, one must use heavy solenoids to switch the motor's polarity. Most Maytag models also fall into this category. In new washers, the 20 pound Magic Chef and Admiral fall into this category

Some washers are very difficult to convert because the motor is directly coupled to the washer's drive assembly. Some types even use shafts on both ends of the motor, one for the washer and the other for a water pump. These types are poor candidates for a motor transplant.

*Total Watt-hours per Load of Wash*

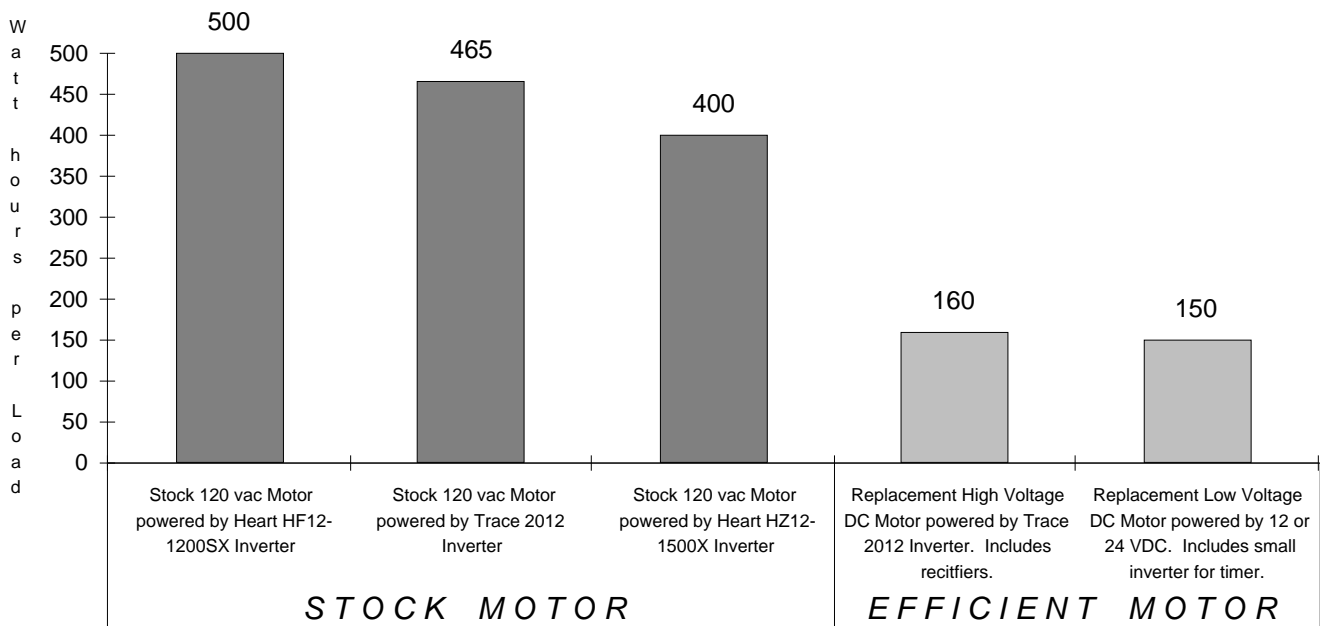

Included here are some of the newer Whirlpool, Kitchen Aid, GE, Frigidaire, Westinghouse, and Kenmore models.

A look into the washer's innards will give you some good information about its capacity for conversion. Is the motor's shaft directly coupled, or does it use a pulley/belt setup? Pulley/belt types are easier to convert. Is there lots of space surrounding the motor, or is it packed in like a sardine sandwich. Chances are the DC motor will be of different dimensions than the ac watt-hog it replaces, so extra space makes the conversion easier

### Can You Do It?

That depends on your "tinkering" experience, the brand and model of washer you want to use, and how much money & time you are willing to spend. I recommend the qualifications-guidelines listed below. If you stick to an easy-to-convert washer, it's not all that difficult. The number of parts required aren't many and the actual installation shouldn't take longer than an afternoon. There are basically four approaches to take if you want to enjoy the energy-savings of a converted washing machine.

#### 1) Convert from scratch with no instructions

For non-techies, forget this approach. For techies, have fun! You are exploring new territory and will experience the hazards faced by all pioneers. Keep at it, and do it right. Document your work and let the rest of us know the path you followed.

#### 2) Convert from scratch, guided by instructions

Published, "do-it-yourself" instructions can be either brief or comprehensive. The briefer they are, the more experienced/skilled you must be in mechanics/electronics to read between the lines. The only one I have experience with is the booklet, "Convert your washer to 12 Volts" by David Copperfield. It is a bit dated, contains some errors, and is quite brief for most models. It does adequately cover the most popular second-hand washers (and Maytag wringers) IF you are experienced with "creative" repair of things.

#### 3) Convert with a "Do-It-Yourself" kit

I'd recommend you have at least minimal mechanical and electrical skills. Or get a kit and have someone help you. Which kit? Like everything else, there are kits and there are kits. Quality, completeness of parts, instructions, and price are the key concerns. Read the product fact-sheet to compare these variables and to find out what the job requires. Compare quality and completeness of each kit. For a DC system, does robust, flexible lead-in wire and connectors come with it? How about an enclosed electrical connection box (enclosure)? Does the new motor have just two poles/brushes (so-so) or four poles (longer

maintenance-free life)? For large/extra large capacity washers, is the kit's motor only a 1/4 horse, when a 1/3 or 1/2 horse would run cooler and last longer. For automatic washers to be run on DC, does a small inverter come with the kit? What kind of inverter is it, a square wave type with no voltage regulation? Compare and finally make sure the kit is for your brand and model of washer.

#### 4) Buy an Already-Converted, Brand New, Full-Size Washing Machine

I haven't seen one on the market...yet.

### How Much Does It Cost?

These home powered examples do not include any costs for heating wash water...See the sidebar attached to this article. If you buy new quality conversion parts, you could spend over \$500. A conversion cost even this high would be worth it in the long run, especially for "heavy users". Consider these examples using full-size, standard ac washing machines and methods.

At the laundromat, wash five loads of clothes per week at \$1 per load, and you'll spend more than \$500 in two years. That doesn't count getting there and back or the eco-costs of most on-grid power generation. In the end, none of this expense went toward upgrading your home power system.

With PVs and batteries, five loads of clothes per week requires roughly two, 50 watt PV panels (\$700) dedicated just to the washer, a large inverter (\$1,000) dominated by the washer whenever you do laundry and 1,400 extra watt-hours of battery capacity (3 cloudy days of storage).

In stark contrast to the last example, a converted washer, also at five loads/week will cost the price of the conversion (between \$250 and \$550), only one, smaller 35 watt PV panel (\$250) dedicated just to the washer and 480 extra watt-hours of battery capacity (3 cloudy days of storage). If you already own a large inverter, it is now freed to run other high-powered loads or to just rest. The efficient 115 Vac versions require a medium-to-large size inverter and consumption will be about 10% higher than the "straight" DC versions.

### Access

Author: Jim Forgette, POB 207, San Andreas, CA 95249.

Parts & Instructions: Alternative Energy Engineering (AEE) Catalog, 800-777-6609. You can also get "Convert your washer to 12 Volts" by David Copperfield from AEE.

Motors: Suntools, 707-964-9019 or AEE, 800-777-6609.

Kits, motors, parts, advice, & new efficient washers, available late 1991: Wattevr Works™, POB 207, San Andreas, CA 95249.



### Be Wary of "Official Efficiency Ratings"

For home power systems, the official energy-efficiency ratings of washers are inappropriate, since the cost of heating the water is included. For an "on-grid" home (water heated by natural gas or electricity), the cost of heating wash water is overwhelmingly the main expense. For "off-gridders", producing the electricity to run the washer is the primary expense. In fact, the on-grid cost of heating wash water so dwarfs the cost of electricity to actually run the washer, that "Consumer Reports" doesn't even include the washer motor's electrical consumption in their rating! What's actually being rated is the power consumption of the hot water heater, not the washer itself.

To someone on home power with a solar hot water system (homegrown and/or paid for), these ratings are absurd. "What do they mean, hot water costs? Why don't they include the cost of pumping water too, or the cost of soap and bringing it home!" So in shopping for a new washer (or any appliance using hot water), home power folks comparing official efficiency ratings should be aware what those ratings are measuring. Perhaps these ratings should also provide data for just the electrical consumption of the appliance itself. Maybe we need our own rating agency— "Conserver Reports"? Jim Forgette

Cimarron  
Mfg.  
AD

Utility  
Free  
AD



**STOP**  
Feeding The  
**WATT-HOGS**  
Ordinary  
Washing

**"Converted" Washers use  
only 1/3 the electricity!**  
For 12 VDC, 24 VDC, & 115 VAC

- Genuine "Guzzle-Buster Kits™"- starting at \$250
- Parts: Convert from "sctatch"
- Brand New Washers (available soon)

With "warehouse" prices, we still "tailor-fit" each customer. To receive your "tailor-fitting" and helpful guide booklet, send \$10 to:

**WATTEVR WORKS™**  
P.O. Box 207, San Andreas, CA 95249  
(\$10 cheerfully refunded if you are not satisfied.)



BOBIER  
FULL  
PAGE  
AD

## NESEA

### Earth Days ! Mirth Days ! Buttons For Every Daze !

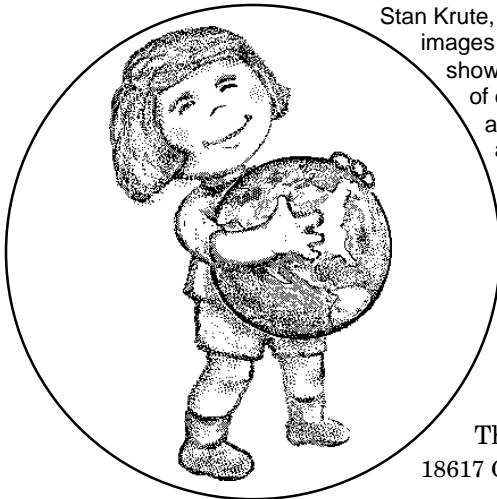

Stan Krute, Home Power's maniacal mousing artiste, offers many images in many forms for many moods. The 2.5" buttons shown here are especially popular this spring. Get ten of either design for \$10! Ten of each for \$18! Ten assorted Home Power buttons for \$10! Ten assorted Pinhead buttons for \$10! Both assortments for \$18! Catalogs for \$1, applicable to any future purchase! Make checks out to Stan Krute. And, above all: Remain calm. Call if confused.



The **Soda Mountain** Company  
18617 Camp Creek Road Hornbrook, California 96044  
phone: 916-475-3428

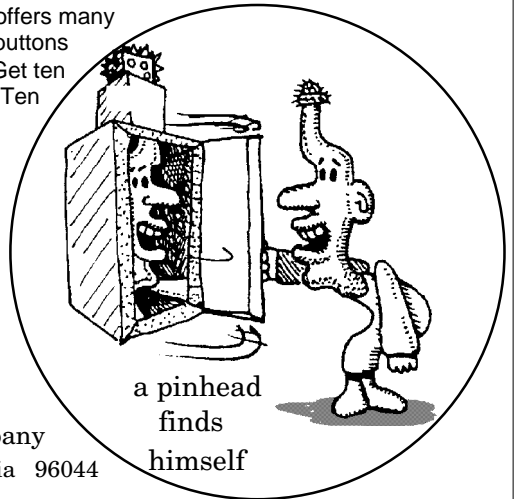

a pinhead  
finds  
himself

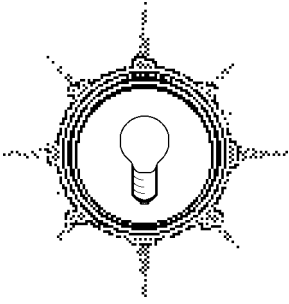

# Home Power Magazine

**\$10 per year (6 issues) to US Zip Codes via 2<sup>nd</sup> Class**  
**\$20 per year (6 issues) to US Zip Codes via 1<sup>st</sup> Class**

If you want to subscribe to Home Power Magazine, please fill out the subscription form below, write a check or money order, & drop it in the mail. Tape the form well or use an envelope so your check doesn't fall out in the mail. We encourage you to use this form to communicate with us.

For those wishing **Back Issues of Home Power, or international subscriptions**, please see **page 95**.

1st Class Sub-\$20 to USA Zip Codes     2nd Class Sub-\$10 to USA Zip Codes     Subscription Renewal Specify Class     Change of Address Include old Address     New Info on your System

**PLEASE PRINT CLEARLY. GIVE YOUR COMPLETE ADDRESS.**

**NAME** \_\_\_\_\_

**STREET** \_\_\_\_\_

**CITY** \_\_\_\_\_

**STATE** \_\_\_\_\_

**ZIP** \_\_\_\_\_

The following information regarding your usage of alternative energy will help us produce a magazine that better serves your interests. This information will be held confidential. Completion of the rest of this form is not necessary to receive a subscription, but we would greatly appreciate this information so we may better serve you.

**FOR OUR PURPOSES WE DEFINE ALTERNATIVE ENERGY AS ANY ELECTRICAL POWER NOT PRODUCED BY OR PURCHASED FROM A COMMERCIAL ELECTRIC UTILITY.**

**I NOW use alternative energy (check one that best applies to your situation).**

As my only power source

As my primary power source

As my backup power source

As a recreational power source (RVs)

**I want to use alternative energy in the FUTURE (check one that best applies).**

As my only power source

As my primary power source

As my backup power source

As a recreational power source (RVs)

**My site has the following alternative energy potentials (check all that apply).**

Photovoltaic power

Water power

Wind Power

Other

I now use OR plan to use the following alternative energy equipment (check all that apply).

NOW

FUTURE

Photovoltaic cells

Wind generator

Water power generator

Battery Charger

Instrumentation

NOW

FUTURE

Gas/Diesel generator

Batteries

Inverter

Control systems

PV Tracker

FOLD HERE

& TAPE

*Please write to us here. Tell us what you liked and didn't like about Home Power. Tell us what you would like to read about in future issues. Thanks for your time, attention & support.*

Check here if it's OK to print your comments as a letter to Home Power.

FOLD HERE

Return Address

---

---

---

Place  
29¢  
Stamp  
Here

**Home Power Magazine**  
**Post Office Box 130**  
**Hornbrook, CA 96044-0130**



Things that Work!  
tested by Home Power

# Things that Work!

## Trade Wind's Wind Odometer

Mick Sagrillo

©1991 Mick Sagrillo

**F**olks wanting to do a wind site analysis are usually stunned by the cost of recording anemometers. Wind odometers or recording anemometers start at around \$350, but most cost \$1,200 and up. That's affordable for a wind farm, but what, you may ask, is available for the homeowner? For years, I tried to find affordable wind recording equipment. I finally stumbled onto the Wind Odometer made by Trade Wind.

### Hardware

I have many expensive wind recording instruments, so I was skeptical when I found this budget model. I have been selling Trade Wind anemometers for years, and am familiar with the high quality of their relatively inexpensive equipment. But somehow this odometer had escaped my attention. Unable to pass up the temptation, I ordered one. It arrived promptly via UPS. It was well packed, preventing damage by overenthusiastic truck stuffers. The unit consists of the odometer, a 3-cup plastic anemometer head, a ten inch PVC mast for the anemometer, sixty feet of two conductor cable, and some brief instructions.

The odometer comes with a small power supply (wall cube) for use with a standard 115 vac power outlet. No 120 vac available? No problem. The instructions indicate that you can simply cut the wires to the wall cube and reconnect to any 12 VDC power source. Be sure to get the polarity right. The odometer consumes only 1 milliAmpere of current at 12 VDC. When operated by the wall cube, the odometer is much less efficient due to losses in the power supply. The odometer can be run by D sized flashlight batteries for remote applications.

### Installation

The set up is simple. Mount the anemometer somewhere high, and connect the two conductor cable to the anemometer. Connect the other end of the cable to the odometer and you're ready for business. The anemometer can be mounted as far as 500 feet away from the odometer. If you are collecting data for a future wind generator, then place the anemometer at the hub height of the planned generator. The higher the anemometer, the greater the average wind speed. See HP#21 article on Wind Generator Tower Height.



Above: Trade Wind's Wind Odometer. Shown are the anemometer, the odometer display and the power supply.

### How It Works

The Wind Odometer is an event totalizer that counts pulses. Operation is simple. The anemometer head generates an electrical pulse every time it spins around. The electronics in the Wind Odometer counts these pulses. The display of the odometer shows an accumulative count which increases as the wind blows. The five digit display of the Wind Odometer looks just like the odometer on your car and works the same way. In a car's odometer, to find the distance between two points simply subtract the starting odometer reading from the reading when you reach your destination. This gives you the number of miles you have driven. The Wind Odometer works similarly, but reads wind speed in miles per hour. If you take the number of counts displayed by the odometer, subtract the previous odometer reading and divide by the number of hours between the readings, then you get the average wind speed in MPH for that period.

The main difference between the Wind Odometer and more expensive data loggers is that the data loggers keep track of the elapsed time, and do the necessary calculations, for you. What expensive data loggers accomplish electronically, the Wind Odometer's user does manually with a watch, calendar, and a piece of paper. Simply jot down the count on the odometer, the date, and the time. I suggest writing down the count on the odometer daily at the same time of day. Simply subtract yesterday's reading from today's and divide by 24 (hours per day). The result is the average wind speed in miles per hour for the preceding day. You can also use a running time meter to keep track of the elapsed hours.

There is an LED on the odometer that can be used to measure wind speed in miles per hour. Simply count the number of times that the LED flashes in a sixty second period. That's the wind's speed in miles per hour.

While the anemometer is waterproof and designed to live outside, the odometer is not. If you are going to use the odometer in an outside location be sure to put it in a waterproof box such as a Hoffman enclosure.

### Conclusions

The Wind Odometer lists for \$153.50. It comes with a one year factory warranty.

At various times, I have looked into building a wind odometer or recording anemometer. Between the electronics to do the counting, the actual anemometer (which must live outside in the wet and wind), and the display, I figure that it would cost well over \$150 in parts. Not to mention the time and R&D involved. Homebrew anemometers using panty hose containers or split ping

pong balls aren't worth the trouble of building. For my time and money, the Wind Odometer is a bargain.

### Access

Author: Mick Sagrillo, Lake Michigan Wind & Sun, E3971 Bluebird Road, Forestville, WI 54213 • 414-837-2267.

Manufacturer: Trade Wind Instruments, 1076 Loraine Street, Enumclaw, WA 98002 • 206-825-2267. The Wind Odometer is available directly from Trade Wind or from your wind generator dealer.





**LAKE  
MICHIGAN  
WIND & SUN**

Largest selection of used wind equipment available, including wind gens, towers, both synchronous & stand-alone inverters & Aeromotor H<sub>2</sub>O pumps.

We repair & make parts, blades & governors for most wind gens, pre-REA to present, specializing in Jacobs Wind Electric.

Whisper 1000 (\$1290 & we pay the shipping)

Trade Wind's Wind Odometer (\$140 & we pay the shipping)

Best prices on Trace Inverters & Bergey Wind Generators.

**Lake Michigan Wind & Sun**  
3971 E. Bluebird Rd., Forestville, WI 54213  
**414-837-2267**

### SYSTEM ELECTRIC

*Best Prices & Courageous Service!*

Panels, Controllers, Inverters, Refrigerators, Pumps, Lead Acid, NiCad or Nickel Iron Batteries & Trackers. Typically:

- Kyocera K-51s Carton of 4, \$300 ea. Delivered
- Sunfrost RF-12 \$1474, RF-16 \$2138 FOB + Crate
- Heliotrope CC-60B \$151, 2500 PSTT \$1328 Delivered
- SURRETTE HG-1 6V/105AH \$75 FOB

"Delivered" is via UPS Continental USA

All Prices are for Limited Time Only

P.O. Box 67 - Lyndon, VT 05849 • (802) 626-5537



Things that Work!  
tested by Home Power

# Things that Work!

## SunAmp's Bar Graph Voltmeter

Richard Perez

**B**attery voltage is essential information for system users. Accurate voltmeters are not only expensive, but often confusing. SunAmp has made a very rugged and accurate bar graph voltmeter, the BCM. This meter is simple to install and use. The meter uses a vertical line of color-coded Light Emitting Diodes (LEDs). It provides, at a glance, accurate information about his battery's voltage.

### SunAmp's Bar Graph Voltmeter

The shipping container and documentation are more than is required. This unit could fly to the Moon in a paper bag and be installed by the average ten-year old. The bar graph voltmeter is totally solid state, tightly sealed, and tiny. It is 2 inches wide by 4 inches tall and is about 3/4 of an inch thick. It is encapsulated in potting compound.

The SunAmp BCM uses a color-coded vertical string of thirteen LEDs. BCMs are made for 12, 24, or 48 Volt systems. Here's the voltage scale for the 12 Volt model I tested. At the bottom of the scale is a red LED that flashes when the battery voltage is less than 11.6 VDC. This LED indicates that the battery is about totally discharged. The next two red LEDs up the scale light at 11.65 and 11.7 VDC, indicating that the battery is close to empty. Next comes two amber LEDs that light at 11.89 and 12.02 VDC. The next six green LEDs light at 12.14, 12.26, 12.38, 12.51, 12.63, and 12.75 VDC. This string of green LEDs roughly indicates a lead-acid battery's state of charge over most of its normal operating range. A green LED lights at 13.70 VDC indicating the battery is fully charged and undergoing float charge. A flashing red LED at the top indicates a battery voltage of 14.80 VDC.

The BCM uses the "moving dot" or single LED lit mode, rather than lighting all LEDs below the indicated voltage or "string mode". This provides the same accuracy and resolution while saving power because only one LED is lit at a time.



### Installing the Bar Graph Voltmeter

The BCM is very simple to install. It comes with a five foot cable containing two wires, red and black. Each wire has a battery ring connector attached. The red wire goes to the positive pole of the battery and the black to the negative. The BCM survives reverse polarity hook-up, so even if you reverse the wires no damage will occur. There is a double-stick Velcro fastener on the back. You can stick it anywhere. Installation of this meter is trivial.

### The Test System

I installed the BCM in our test system on 26 September 1990 and it has operated 24 hours per day since then. The BCM is wired directly to a 12 Volt, 100 Amp-hr Alcad nickel-cadmium battery. The system is sourced by two photovoltaic modules (one ARCO 47 W. and one Solarex 55 W.) via a PV regulator (Heliotrope CC20). The inverter is a PowerStar UPG model.

This system is in daily use on Agate Flat. It powers five OSRAM EL fluorescents, a Sangean AM/FM/Shortwave radio, all our small nicad rechargers (there is a fleet of 'em), and a satellite TV system. I installed this system to test equipment without modifying the main power system. This small PV/nicad system supplies most of our lighting and informational needs. Its flexible nature allows us to install and test equipment in a working system without having to shut off our world.

### BCM Performance

I have been checking the BCM's readings against a Fluke 87 Digital Multimeter for

## Things that Work!

six months. The Fluke 87 DMM has a DC accuracy of 0.1%. The BCM indicates within the 0.5% accuracy claimed by its maker.

I like the simplicity and utility of this meter. Its color coding is easy to understand. The flashing LEDs at the bottom and top really get my attention. I like its rugged, sealed construction. It's even waterproof! This meter will certainly outlast other less accurate types costing more.

Power consumption is around 0.1 Watts; it's efficient enough to be left on line all the time. Compared to other meters using LED displays, the power consumption of the BCM is very low.

### Conclusion

SunAmp has made an easy to install, easy to understand, and highly accurate LED bar graph voltmeter. The BCM

has a 5 year warranty. Its manufacturer's suggested retail price is \$59.00 and it's worth it. Other bar graph voltmeters are available, but none have this combination of accuracy, utility, and ruggedness.

### Access

Author and Tester: Richard Perez, C/O Home Power, POB 130, Hornbrook, CA 96044 • 916-475-3179.

Manufacturer: SunAmp Power Co., 1902 N. Country Club Dr., Mesa, AZ 85201 • 602-833-1550.



Sunfrost  
AD

Zomeworks  
AD

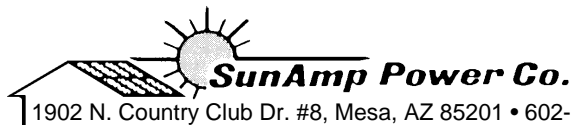

1902 N. Country Club Dr. #8, Mesa, AZ 85201 • 602-833-1550 • fax 602-833-1711



We manufacture a full line of high reliability and competitive priced VOLTAGE REGULATORS.

TOTAL PV SYSTEM CONTROLS , DUSK-DAWN LIGHT TIMERS AND CUSTOMIZED CONTROLLERS. SunAmp is a one stop supplier for completely designed package systems for area & sign lighting, remote home power & water pumping. Our staff of trained engineers can assist you on planning. **CATALOG \$3**

**BEST STOCK • FAST SERVICE • DISCOUNT PRICES ON ALL OF OUR CATALOG ITEMS YEAR ROUND**

Solarjack SDS Pump • PowerStar Inverters • Heart Inverters • Powerguard Regulator-14 Amp • Sunamp Regulator • 12V Motion Sensor • Heliopower Solar Lantern • PL 113w Fluor. Floodlight  
**DEALER INQUIRIES INVITED**

**• VISA/MASTERCARD/ORDERS • CALL TOLL FREE 800-MR SOLAR •**



# Tech Notes:

## UPGRADE FOR TRACE INVERTERS

Bob-O Schultze-KG6MM

**T**race Engineering, Arlington WA, has announced an upgrade on their 2000 series inverters. Trace has long been a leader in inverter technology for the home power market, not only in sales, but for high reliability, efficiency, and good value. For anyone who has tried to hardwire one of these babies, this update is good news indeed.

### The Connection

Formerly, the barrier strip provided for direct wire hook-up was inside the inverter. Trying to get three #12AWG wires (forget anything larger), or six wires, in the case of the standby option, was a real rassel. The gang at Trace have listened to installers' input and have brought the hardwire connectors through the case to the outside. A metal cover protects the external connectors, but the cover is not punched out to accept conduit fittings. It would seem like a logical and easy thing to do.

This external barrier strip makes the hook-up much easier. This allows using up to #8 AWG wire for the connections. For those 2000 series inverters capable of producing over 20A @120vac, or for fairly long wire runs, this means compliance with the NEC and accepted wiring practices is now possible.

### A New Safety Feature

Trace has also incorporated a 30 Amp 120 VAC input circuit breaker into the 2000 series upgrade. This also is a welcome addition. When a Trace with the SB (standby charger) option detects AC from the grid or a generator at its input, it does two things. After sampling the power and checking it for proper voltage and frequency, the inverter becomes a battery charger and, at the same time, passes the power from the external source to whatever circuits are normally connected to its output. This creates the possibility that the combined current of the charger and the circuit loads could exceed the safe ampacity (current carrying capability) of the inverter input wiring, even though the AC output circuits from the Trace are properly fused. The 30 Amp breaker on the inverter's input circuit provides a means of protection.

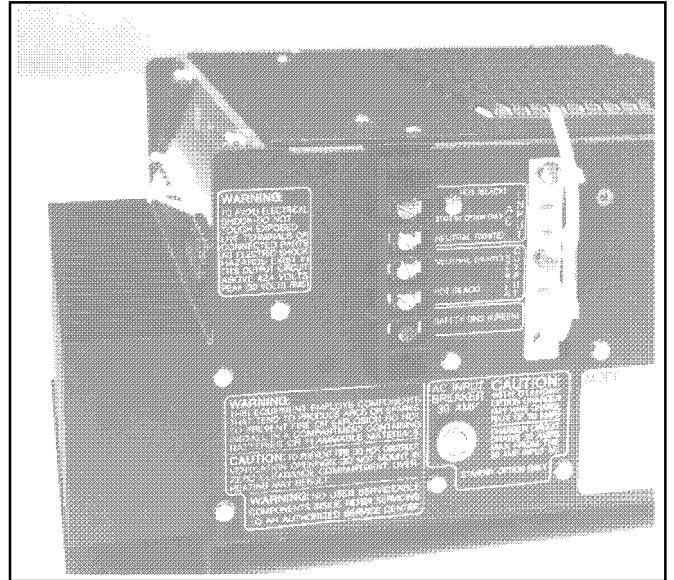

Above: A new Trace 2012 inverter with the cover removed and 120 vac wiring strip exposed.

### A Revised Manual

As if these changes weren't enough, Trace has also revised the 2000 series owner's manual. The diagrams are now much clearer and easier to understand, especially the placement of switch #1, the "Search Mode" switch. Setting up an inverter, especially one with as many features as the Trace, is a fairly complex job. Writing a technical manual that a non-techie can understand is a real trick. The folks at Trace have done a bang-up job. There's even a section on problem loads. Not every appliance digests inverter power gracefully. A few don't run up to speed or as efficiently as intended. A very few even fry and die. It's to Trace's credit and a measure of their honesty that they point out the known offenders and warn you off.

I have just one complaint with this manual. When you first connect a 2000 series inverter to a battery, there is a fairly loud snap and accompanying spark as the input filter capacitors charge up. The first time this happened, it scared the pudding out of me. I thought I had somehow reversed the polarity of the connections. Over 50 installations later, eventhough I know it's coming, it gets me every time. A warning in the manual would go a long ways toward preventing premature heart failure.

### Conclusion

Ya done good, guys. The modifications will make it easier for do-it-yourselfers and experienced hands alike to make a good, safe installation. The price? Same as

## Tech Notes

usual! As a postscript, Bob Summers at Trace has promised a redesign of the access cover to accept conduit fittings soon. Good show.

### Access

Author: Bob-O Schultze is the owner of Electron Connection, POB 203, Hornbrook, CA 96044  
California Electrical Contractor License #613554.

Manufacturer: Trace Engineering, 5917 - 195th N.E.,  
Arlington, WA 98223 • 206-435-2229.



SUNELCO  
AD

**PUMP WATER FREE** to garden, etc. Amazing hydraulic "RAM" pumps uphill automatically without motor, fuel, or electricity.

**FOLK RAM PUMPS** are used for:

Watering the family garden

Supplying water to a pond

Watering livestock, supplying dairy barns

For household use and fire protection



American Made

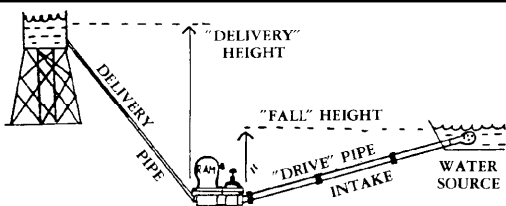
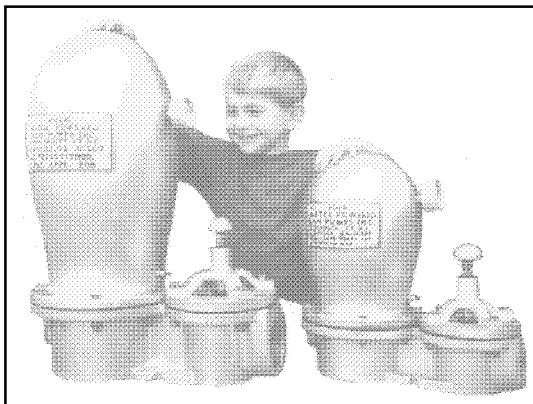

free information send S.A.S.E. to:

**FOLK WATER POWERED RAM PUMPS**  
2770 White Court, N.E. Conyers, GA 30207

Phone: (404) 922-4918

ACTIVE  
TECHNOLOGIES  
AD

# The Basics— System Design

Richard Perez

©1991 Richard Perez

**S**ystem design harnesses a site's specific renewable power sources. System design precisely determines the right type and size of energy hardware required to meet the system's power needs. Here we decide which power sources to use—solar, wind, or hydro. We decide the type and size of the power sources—how many PV panels or how big a wind or hydro turbine. We decide the type and size of the system's battery. We decide the types and sizes of the inverter, controls, and instrumentation. A system's cost and utility are determined by these critical decisions.

## A Big Deal?

Yes, system design is a big deal. Proper design requires the information generated from the system's power use survey and the system's site survey. The system's designer must match the available natural power sources with the specific electrical power requirements of the system's users. If there is no thorough power use survey or site survey, then it is impossible to design the system. So, before you can specify any hardware, you must do your homework. If you are vague on the details of the system's power use, or surveying a site for renewable energy potential, then see *The Basics in Home Power #21* about use and site survey.

The decisions made in designing a renewable energy system will determine if the system is effective or not. Each system is unique. Each system is located in a different location with differing power requirements. A system should fit its user like a hand-made pair of boots. Your system should be as unique as you are. Your system should be as unique as your site. Don't accept a generic, off-the-shelf system. Your RE system will provide a lifetime of effective power if it is properly designed. If not properly designed, then it will leave you in the dark and empty your bank account, all at the same time. System design is the place to discover any mistakes— in theory and on paper, BEFORE you spend money on the wrong hardware.

## System Costs

The decisions made in a system's design directly effect the system's cost. The design phase of a RE system is a very good time to consult someone with current knowledge and extensive experience. The details of which PV module to use, which hydro to buy, how high to put up the wind machine, what kind of battery, how big of

a battery to use, and myriad other details greatly effect a system's cost. If you want a cost-effective system, then work with someone who knows how to design a system, or learn the process yourself. The shortest path to a well-designed system points directly to your local, installing RE dealer. These guys are familiar not only with the latest hardware and how to apply it, but also your local renewable energy resources.

## Help!

This article is designed to give you the Basics of system design. It provides enough information for you to discuss your situation intelligently with someone familiar with renewable power hardware and your local environment. If you are going to specify your system without the aid of a techie, then you will need more information than is provided here.

Why don't I tell you all the information you need? Well, I've been involved in well over a hundred of these systems in the last twenty years, and I'm still learning new things daily. The hardware used in RE systems is changing rapidly. Consider that an entire book could be written on each hardware component in the system. That's a fact; I know because I've written one on batteries alone. Consider that the combinations of different types and kinds of hardware number in the thousands. Consider that a system's designer must select from these thousand of combinations the exact set that matches your use and site, and at the minimum cost to you.

According to our correspondence, many Home Power readers have designed their own systems. They also tell us of many errors and many misspent dollars. It is possible to design a system using the trial and error method. It is also very expensive, very slow, and very frustrating. I don't mean to discourage anyone from

## The Basics— System Design

learning or blazing new trails. I just want you to be aware of what lies ahead. If you have the commitment to do the job right, then the user-designed system is every bit as effective as one designed by a professional. In some cases, the user-designed system is better than can be done by any professional. After all, who knows your needs and your site better than you do?

### The Flow

Being a digital nerd, I have concocted a flow chart for the decision making process that is system design. This flow chart shows what you need to know at each stage of the process. It also shows how to modify the system and the decisions required when changes are made.

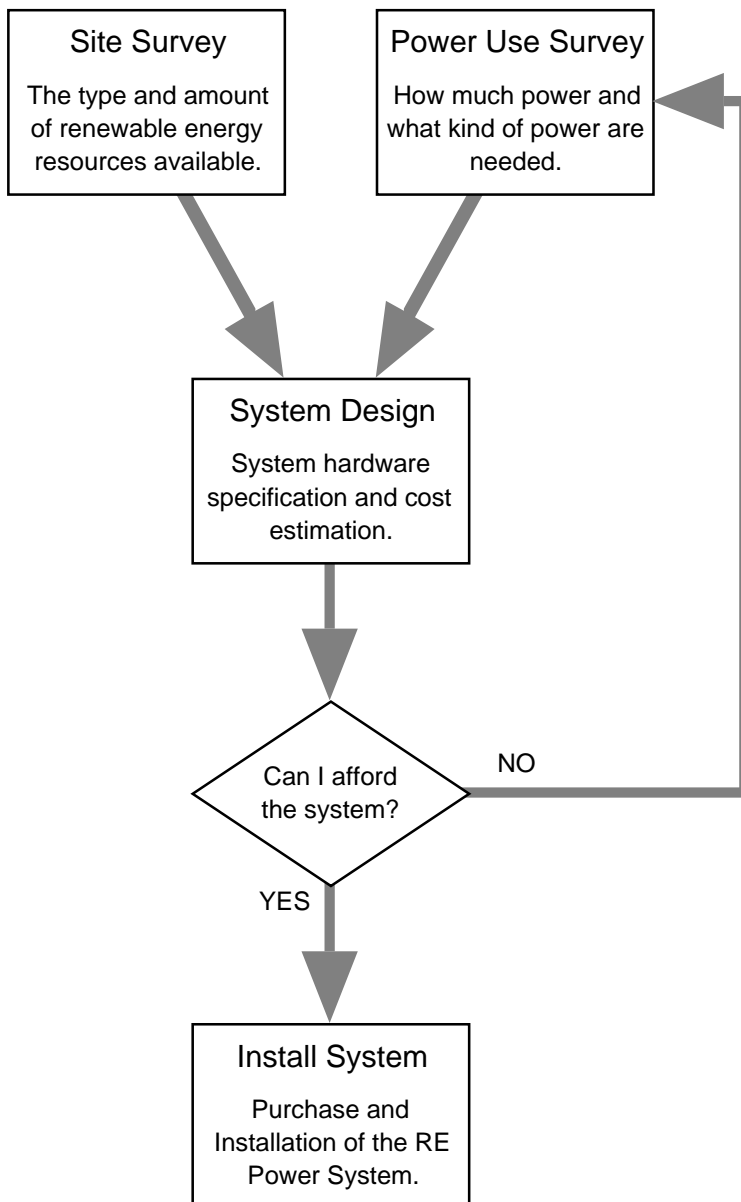

### Using the Flow Chart

The major feature of the flow chart is the feedback loop connecting the decision "Can I afford the system?" with the Power Use Survey. If after all the hardware is specified the user cannot afford the system, then go back to the Power Use Survey and reduce the power consumption. In most cases, reducing power consumption is merely a matter of substituting efficient appliances for power pigs, or using of electric power only where it is cost-effective. In short, trim off the fat, and model the system again. Less consumption requires less hardware and this reduces the system's cost. Continue this feedback process until you have specified a system that you can afford.

### The Particulars of System Design

Each renewable power resource is differently applied. A system sourced by hydro power for example will contain different kinds and quantities of hardware than a wind powered system. All systems, however, share a common design approach employing four basic classes of hardware.

1. **Power Sources**— these may be photovoltaic, wind, or hydro powered. The power source produces the electric power.
2. **Power Processors**— these are inverters, controls, and instruments. The power processing equipment changes one form of power into another, controls the amount of power delivered to the batteries, and measures the electrical parameters of the power.
3. **Power Storage**— here power is stored in batteries for use when the source(s) aren't producing.
4. **Power Users**— these are the system's electric appliances. The appliances are why we're doing all this. The jobs they perform are the reasons why we need electric power.

Almost all systems will employ these four classes of hardware. Almost all systems use this hardware in the same fashion displayed in the system block diagram that follows. As time passes, more of us are adding a second power source to backup our primary source. Wind and hydro are excellent compliments to a system primarily powered by PVs. When the sun isn't shining, it is often raining and the wind is blowing. In most cases, the secondary renewable power source feeds the system's batteries, just like the primary power source.

# A HOME POWER SYSTEM

## The AC Side

120/240 vac, 60 Hz. Generator—  
Wind Turbine, Hydro, or Engine

## The DC Side

Low Voltage Power Sources—  
PV Array, Wind Turbine, or Microhydro

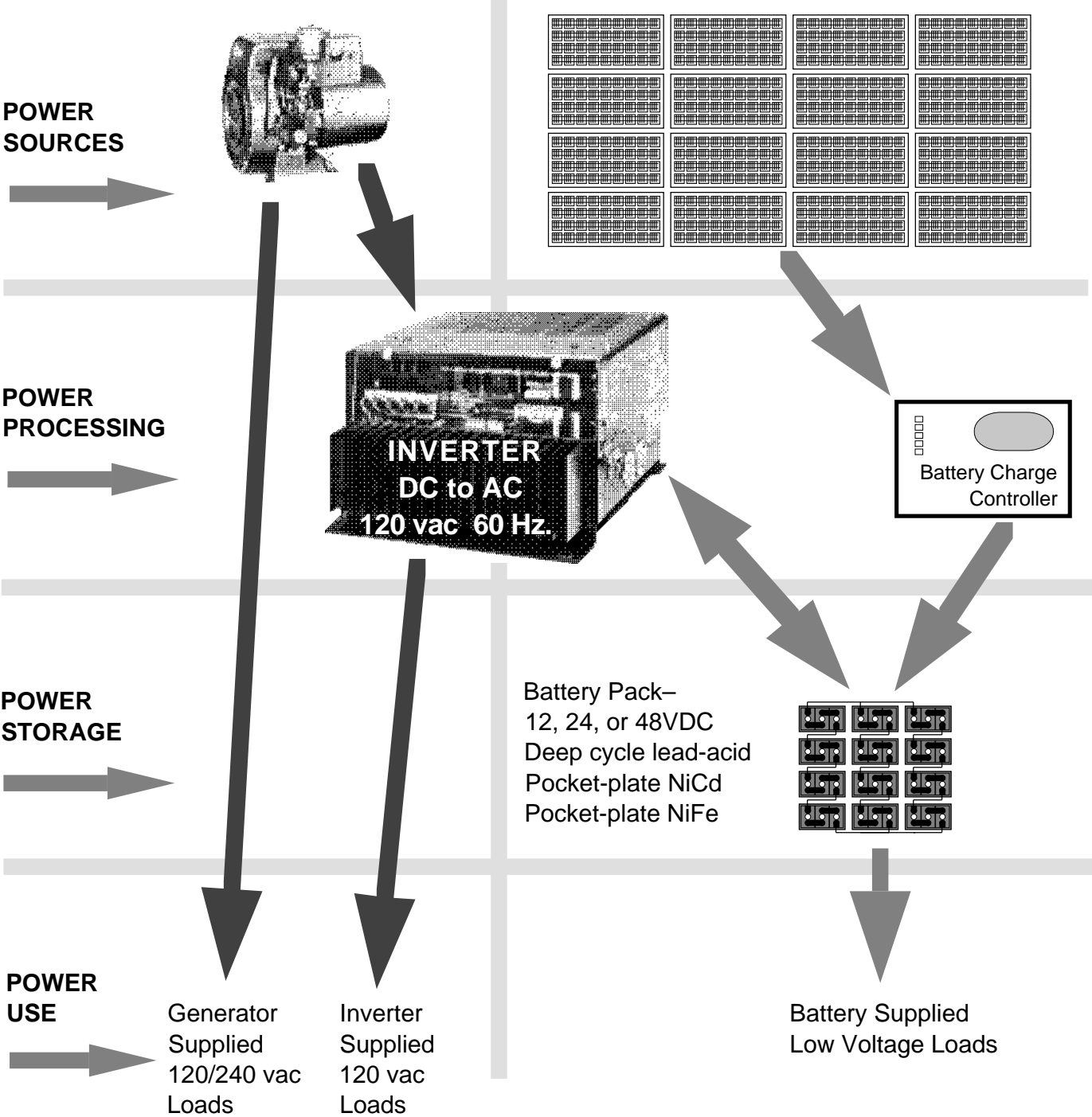

### System DC Voltage

In the past, almost all systems used 12 VDC as their base voltage. This was because the systems were small and extensively employed 12 VDC appliances powered directly from the battery. Now, with the arrival of efficient and reliable inverters, 12 Volt use has declined and 24 VDC is becoming the favored battery voltage. At this moment, the system's DC voltage should be determined by how much power the system cycles daily. Systems producing and consuming less than 2,000 Watt-hours daily are best served by 12 Volts. Systems cycling over 2,000 and less than 6,000 Watt-hours daily should use 24 VDC as a base voltage. Systems cycling over 6,000 Watt-hours daily should use 48 Volts.

System voltage is a very important factor effecting the choice of inverter, controls, battery chargers, and system wiring. Once these components are bought, they usually cannot be changed. While some hardware, like PV modules, can be reconnected from 12 to higher voltages, other hardware like inverters, controls, and wiring is specified for a particular voltage and must operate there. There are specific exceptions to this rule that will be covered in the material that follows.

### Batteries

All systems, except large hydros and wind machines making 120/240 vac directly, use a battery. The battery stores power for use when the renewable power source is not producing. For example, a PV system is useless at night without a battery. Wind systems must use a battery to store power for windless periods. The choice of what battery technology to use is critical and greatly affects overall system performance and cost.

There are now three battery technologies generally employed in home power systems: deep-cycle lead-acid, nickel-cadmium, and nickel-iron. Each battery type is differently sized and applied. For example, all lead-acid batteries will last longer if they are not fully discharged regularly. For this reason, lead-acid batteries are sized so that at least 20% of their rated capacity is never used. Other types of cells, like the alkaline nickel-cadmium and nickel-iron types tolerate deep cycling without premature aging and failure. The least expensive battery to purchase is lead-acid. Carefully used lead-acid cells will last about ten years. While alkaline batteries initially cost about two to three times as much as lead-acid types, they last between three to six times longer. This question of initial cost versus lifetime cost occurs repeatedly in system's design. Each case is specific, but a rule of

thumb is, "Buy the best hardware you can possibly afford." Higher quality components always cost more, but they give better service and last longer. In most all cases, they are more than worth their additional cost. A word of advice, don't use automotive type lead-acid cells in renewable power systems. These cells are optimized to do only one job, starting a car. They are very ineffective and fail rapidly under deep-cycle service.

Temperature plays a big role in choosing a battery technology. If your battery spends several months below 45°F., then use alkaline types rather than lead-acid. Lead-acid cells have poor low temperature performance and must be kept warm in cold climates.

Expandability is also a factor to consider when choosing a battery type. We have two years to add more cells to lead-acid battery. After this two year period, the original lead-acid cells have aged to the point where they will not function efficiently with newly added cells. In any case, all additions to an existing lead-acid battery **MUST** be exactly the same make, model and size of cells as the originals. In the case of alkaline batteries, this is not true. Alkaline cells can be paralleled to an existing alkaline battery at any time and need not even be of the same size and make. So lead-acid systems are only expandable within the first two years of operation, while an alkaline battery can be expanded anytime.

A high quality lead-acid battery will cost about \$0.12 per watt-hour of stored electric power. A reconditioned nickel-cadmium or nickel-iron cell will cost about \$0.35 per watt-hour stored. New nickel-cadmium cells will cost about \$0.80 per watt-hour stored.

### Inverters

Five years ago, a good inverter lasted about a year. Now inverters have become ultra-reliable and are electrically bullet-proof. The criteria to use when choosing an inverter are, in order of importance: reliability, efficiency, utility, and price. Note that price is last on the list.

A reliable inverter must automatically protect itself from the following conditions: output overloading, overtemperature, high battery voltage, and low battery voltage. These protection functions are included in every high quality inverter.

Any inverter worth owning will have efficiencies in the 88% to 98% area over its entire output power range. Usually an inverter is over 95% efficient between 20% and 85% of its rated power output. Don't accept anything less because the wasted power must be produced and stored by the system. This costs more than an efficient

inverter.

Utility means how useful is the inverter. This is difficult to assess without living with the inverter in your system, and by measuring its output. For example, most inverters employ a high voltage shutoff circuit that turns the inverter off if the battery voltage is too high. While, this may not annoy a lead-acid battery user, but it can be very inconvenient for nickel-cadmium users whose battery undergoes larger voltage excursions while under charge. Other utility factors are technical and require a some knowledge of electronics and instruments to evaluate. So if you're not a techie, then ask a techie who has measured these parameters on a working inverter of the type and size you are considering. Some of these technical factors are as follows. Average inverter voltage output should be as close to 117 Vrms as possible (anything below 105 Vrms and over 130 Vrms flunks). The inverter's peak voltage output (Vpeak) should be a close to 164 Vpeak as possible (anything below 130 Vpeak and above 200 Vpeak flunks). Can the inverter deal with the inductive feedback produced by electric motors, transformers, and fluorescent lighting? The best way to assess an inverter's ability to handle inductive loads is to use an oscilloscope while powering these loads. If the inverter's waveform is radically different when it powers say a lightbulb (a resistive load) and a motor (an inductive load), then the inverter flunks. These utility factors are technical ways of defining the constancy and purity of the inverter's output. The instrumentation and tech knowledge needed to evaluate these inverter parameters are extensive. This is why we at Home Power test so many inverters. At this point, I will say that any inverter that has passed "Things that Work!" testing meets the above mentioned techie requirements. Nuff said...

In terms of cost, an inverter worth having will cost between \$.60 and \$1.00 per watt of continuous output power. Don't even consider full square-wave inverters. They are less reliable, much less efficient, and less useful than the modified sine-wave types. I mention this here because the full square wave types are cheap and you will get what you pay for.

An inverter that produces 1,000 and 2,000 Watts will power an entire household of careful users. This means that the users agree not to run everything in the house at the same time, thereby overloading the inverter. If the household must be able to simultaneously power several large appliances, then consider a 3,000 to 5,000 watt inverter. Or split up the loads into different circuits and

power each circuit with a different 2,000 watt inverter. Surge capability used to be a big problem with inverters. Now, just about all inverters will deliver at least three times their rated output for surge demands. Surge output power is no longer a problem in well designed inverters.

The Power Use Survey will detail all appliances powered by the inverter. List all appliances that will be running at the same time and add their wattages. This figure is the minimum size inverter to purchase. Some inverters can be expanded (like the PowerStar UPG models) or paralleled (like stacking two Trace inverters) for more output. This is a recent development and is greatly appreciated by growing systems.

Different manufacturers rate their inverters in different ways. Ignore the ad verbiage and look for the inverter's CONTINUOUS output rating. This is the truest measure of the inverter's power handling capabilities.

In the past, many of us used the battery chargers offered as options on inverters. This is still a very inexpensive way of getting a high output, electronically regulated, battery charger. For example, the Trace 2012 inverter has a battery charger option that will produce up to 110 Amperes up to about 15.5 VDC. This, however, requires the inverter to change into a battery charger when it is supplied with 120 vac from a generator or from the grid. This complicates the inverter's function and adds about \$220 to its cost. A different approach is to let the inverter do only the job of making 120 vac from battery stored DC power. Use a separate component to recharge the battery. Modern switching supplies are being configured as effective (especially on generator power) and efficient battery chargers. They cost about the same as building the charger into the inverter and offer more utility plus greater reliability.

### Designing a Photovoltaic System

PV systems are the easiest type of all to design. We already have an accurate idea of solar insolation from the Site Survey. We've done the Power Use Survey so we know how much electric power we require on an average day. All that remains is to specify the type and number of PV modules that will produce the power, and type and size of the battery.

### Choosing the right PVs

For a 12 Volt system use PV modules that contain 36 series connected cells. Simply wire two panels in series for 24 Volt operation, and four in series for 48 Volt operation. Stay away from the "self-regulating" PV modules containing 30 or 32 series connected cells.

Self-regulating models still require a regulator in most systems and make less cost-effective use of their cells.

Look for PV modules that carry a full warranty from their manufacturer. Any panel worth having is now warranted not to lose more than 10% of its output power within a ten to twelve year period. PVs are a lifetime investment and not the place to save a few bucks on less than the best.

The most cost-effective PV modules now use polycrystalline or "multicrystalline" silicon material. While the single crystal cells have higher efficiencies, they are also more expensive. Currently, high-quality polycrystalline modules are selling for about \$7 per watt.

### **Sizing the PV Array**

Size the PV array so that it will produce, on an average day at your location, AT LEAST as much power as you consume during an average day. For example on an average day here on Agate Flat, a 48 watt PV module produces 225 Watt-hours of power. We consume an average of 2,480 Watt-hours of power daily. Divide the power consumption by the average output of a single panel and the result is the number of panels required. In this case, 2,480 watt-hours per day / 225 watt-hours per day = 11.02 panels. We actually have twelve modules working now and hardly ever have to resort to a backup power source except during the dead of winter.

Sizing the array so that it produces our average day's consumption is the smallest sized array to consider. There is no penalty for using more panels, in fact there are substantial benefits. The first is the amount of time it takes for the system to refill the battery after an extended cloudy period. The second is the system's ability to withstand unusual periods of high power consumption, like when city folks come to visit and leave all the lights on all the time. The third is that all systems seem to grow and use more power, so with more modules, power production is ahead of the system's growth rather than behind it.

One of the very fine features about a photovoltaic array is that it is easily expanded. If we require more power, we can add more modules to the array at any time. This expandability is unique to photovoltaics and is not possible with wind or hydro turbines. Expandability makes it easy to start small with a PV system and have it grow as the family needs more power and/or can afford it.

### **To track or not to track?**

A tracker is a device that follows the sun's daily motion through the sky. In order for the tracker to be effective the

site must have good access to both early morning and late afternoon sunshine. A site where the sun strikes only between 10 AM and 2 PM is not a good site for a tracker. Does the site have the unrestricted solar access necessary to make a tracker effective? This is determined during the site survey.

If a site has enough sun to make a tracker effective, then the tracker will add about 25% yearly to the PVs power output. This means that the all modules mounted on the tracker will produce about one-quarter more power on an annual basis because they are following the sun's motion. Actually, the tracker's increase is about 45% in the summer and around 10% in the winter.

Trackers cost money just like PV modules. It is not cost effective to track less than eight modules. Under eight modules, we will get more power output for our dollar if we spend the money on more panels rather than a tracker. At eight panels in the system, the tracker starts to pay off. There are exceptions to this rule, for example array direct water pumps. If PVs are directly driving a water pump, without a battery in the system, then it is cost effective to track two or more PV modules. This has to do with technical details like the peak voltage required to drive the pumps electric motor.

### **Choosing a PV controller and instrumentation**

A control is necessary to keep the PVs from overcharging the battery when it is full. There are many types of controls available, so consider wisely before purchasing. Here are some criteria to use when selecting a PV controller. Don't use controls with relays. Relays are electromechanical devices that are hundreds of times less reliable than semiconductors (transistors or FETs). Controls with user adjustability are more useful because we can adjust them to suit our needs. Controls that maintain a constant voltage while regulating are more effective than controls that totally disconnect the array.

### **Sizing the PV system's battery**

Size the PV system's battery with a minimum of four (4) days of storage. Consider our system on Agate Flat that consumes 2,480 watt-hours daily. If we divide this figure by our system voltage of 12 VDC, we arrive at a daily consumption of 206 Ampere-hours from the battery. So four days of storage would be 4 days X 206 Ampere-hours per day or 826 Ampere-hours. If the battery is a lead-acid type, then we should add 20% to this amount to ensure that the battery is never fully discharged. This brings our ideal lead-acid battery up to a capacity of 991 Ampere-hours. If the battery is nickel-cadmium or nickel-iron, then this extra 20%



capacity is not required because alkaline batteries don't mind being fully discharged on a regular basis. Our system at Agate Flat employs 750 Ampere-hours of lead-acid storage. This is less than we need, and we often refuse power because our undersized battery cannot store it. Our battery is over ten years old and soon I will replace it with a much larger alkaline type.

Four days is the minimum storage capacity to install in a new system. Every day of additional storage will pay off in the system's ability to withstand long cloudy periods. In order for a solar system to be totally stand-alone and not require any backup power source, it should have at least seven days of storage in the battery. Those living in places where it is cloudy for extended period might well use an even bigger battery. If you want stand-alone performance from your PV system, then size the battery to withstand the longest cloudy period you ever experience. This can be expensive and it is usually much more cost effective to add a secondary power source, like wind, microhydro, or even an engine/generator.

### Designing Wind Systems

Wind systems are at the mercy of their site survey. Without an extended site survey or real wind data for a specific location, it is really impossible to specify a wind turbine for the system. While PV and microhydro systems are often effectively designed by their users, wind systems should seek help from someone who really knows wind power. While a PV system may limp along with a bad design, wind systems experience catastrophic and total failure due to poor design and/or installation.

### Choosing the Right Windmachine

Again this is a job for someone with experience with all types of wind turbines. Not only must the wind turbine be well made, but it also must fit the wind conditions at your particular site and must produce the power that the system requires. Modern turbines usually produce some specie of low voltage and only the very large units make 60 cycle, 120/240 vac directly. Here is a list of the turbines that work well. This information is provided by Home Power reader and user reports. Any wind machine made by Bergey Windpower will not only work, but it will last. We've had very good reports on the inexpensive Whisper 1000 watt machines made by World Power Technology. In the smaller machines (under 500 Watts), the Windseeker models from South-West Windpower are receiving high praise from their owners. Well-constructed wind turbines will cost between \$1 and \$3 per watt.

### How high is high enough?

As high as you can get it is high enough. The higher you place the wind machine, the more power you will get. Consider 50 feet to be a realistic minimum and after that, go as high as you can. Be sure that the tower is strong

and well installed. Sloppy tower installation can bring the whole system crashing down. A tower's success or failure is a digital event— either the tower stands or it falls. Make sure it stands. Don't scrimp on the tower, this can cost you your entire wind machine, tower, and possibly any buildings underneath the tower. Guyed towers are more secure and less expensive than unguyed towers. Regardless of the type and brand tower you use, put it up right and make sure that it stays up.

### Choosing a wind controller

In almost every case, the manufacturer of the wind machine also makes a regulator for that specific model. So, the user doesn't have to select a regulator because it is bundled in with the wind machine. These controls are shunt types that divert the turbine's output to maintain control of the system's voltage. Diversion regulator schemes are really the only type used, because unloading the wind machine will cause overspeeding and damage to the turbine.

### Sizing the Wind system's battery

The size of a wind system battery storage is determined by the longest period of windless weather. This can be very difficult to determine in advance. For this reason wind systems usually have more days of battery storage than do PV systems. Shoot for a minimum of seven days of storage and extend this to fourteen days if you can afford it. Wind power comes in gusts and spurts, having a large battery makes more effective use of nature's least consistent power source.

### Designing Microhydro Systems

Microhydro systems are defined as hydroelectric systems that produce less than 1,000 Watts (that's 24,000 Watt-hours daily). At the high end, microhydro systems produce enough to run three electrically efficient households. No other form of renewable energy is so reliable or powerful for what it costs. If you have microhydro capabilities at your site, then start smiling now. You have the most constant and inexpensive form of small scale, renewable power. But first, you must have the water. Again (and over and over again) a survey of a site's potential must be done before you can design the system. Fortunately a hydro site survey is easy to do and produces solid dependable data.

In a microhydro system the length and diameter of the pipe must also be specified to suit the situation and the turbine. Consider that the pipe delivering water to the turbine is a conduit for power. Using long runs of small diameter pipe will make even the finest turbine ineffective. The situation with pipe in hydro systems is exactly the

## The Basics— System Design

same as the tower in wind systems. Both provide access to the natural power source and neither are places to save money by specifying marginal components.

### Choosing the Right Microhydro Turbine

Microhydro turbines come in two basic forms. One uses an alternator, just like an automobile. The other uses a permanent magnet (permag) generator/motor. The alternator based machines are for larger systems producing from 100 to 1,000 watts, while the permag units are best suited to systems producing under 80 Watts.

### Microhydro System Controls

Larger systems will use shunt diversion for regulation. This prevents overspeeding of the turbine and premature wear of parts. Smaller systems use regulation schemes that unload the alternator when power is not needed. In all cases, these controls need to be user adjustable. In all cases, the controls should not use failure-prone relays.

### Sizing a Microhydro System's Battery

Microhydro systems are easy to fit with batteries. The microhydro turbine produces constant power all the time. The battery acts as a "flywheel" to smooth out the inevitable peaks of consumption. If a microhydro's battery can store one day's power for the system, then it usually works as well as many days of storage. Microhydros refill their batteries almost immediately after even a little power is consumed from the battery. Microhydro systems are "shallow-cycling" their battery and any ole' thing will last a long time. If you have microhydro potential, then spending your money on good pipe and an efficient turbine is more effective than spending it on batteries.

### Need more info about designing a system?

If you're doing this job by yourself, then you certainly do. I refer you to every issue of Home Power published to date. We've been talking about these specific technical details for more than three years and over one thousand pages to date. We've just scratched the surface. Again, I urge those considering renewable energy systems to consult with someone in the business. I had to figure all this out for myself because when we started out there wasn't anyone in the business. Now, some twenty years later, many of us have learned a great deal about what works and what doesn't. So save yourself much heartache and many dollars, go out and make a new friend who's in the biz. While you still may wish to design and/or install your own system, the help of an adept is invaluable and will save many times more money that it costs.

### Access

Author: Richard Perez, C/O Home Power, POB 130, Hornbrook, CA 96044 • 916-475-3179.



## CRUISING EQUIPMENT AD

### HOXAN PV MODULES INTRODUCTORY SPECIAL! HOXAN 4810

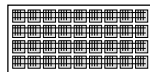

48 W., 3 A., 10 yr warranty **\$299** each in full box of 4.  
Modules in less than full box quantities - \$324 each. FREE  
Trace C-30A control (\$100 value) with 8 HOXAN modules.  
SUN-MAR COMPOSTING TOILET model N.E. (non-electric) \$949.

REFRIGERATORS: SERVEL \$975 SUN FROST at low prices. Best buys on INVERTERS



### 120 VAC COMPACT FLUORESCENT LIGHTS

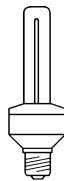

OSRAM DULUX EL 15 watt \$23.50 each, 6 for \$132.  
PANASONIC E-QUAD 27 watt \$27 each, 5 for \$125.  
PANASONIC 15 watt Globe \$15.90 each, 10 for \$137.  
Compact PL 13 watt bulb & adapter \$14 each, 4 for \$45.  
Compact PL 9 watt bulb & adapter \$13 each, 4 for \$40.  
REFLECT-A-STAR 13 watt \$39.50 each.

PL 13 watt FLOODLIGHT for INDOORS or OUTDOORS \$36.

Shipping rates listed in catalog. Prices & special offers subject to change without notice.

### SEND \$3 FOR CATALOG

COMPLETE WIND, HYDRO, & SOLAR ELECTRIC SYSTEMS  
SOLAR & WOOD WATER HEATERS - DC WATER HEATER ELEMENTS  
Grain Mills - DC Motors - Pumps - Fans - Wind Instruments - Amp Hour Meters -  
Electric Garden Tractors - Books - Solar Water Stills - Windmills - Towers

### KANSAS WIND POWER

Route 1-HP, Holton, KS 66436

Try our low prices. Since 1975



## DC ENERGY EFFICIENT PL LIGHTS

with pre-wired ballast

Just screw in & use Introductory offer:

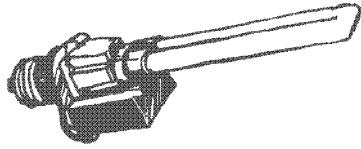

5, 7, 9 & 13 watt 12 VDC-\$33

13 watt QUAD 12 VDC-\$33.50

24 VDC Add \$3

Shipping \$2 per order (48 States)

AC Compact Fluorescents \$18.50 & Up

CATALOG \$5.00

New & Used Panels.

ALTERNATIVE POWER & LIGHT CO.

128 WEISTER CREEK ROAD

CASHTON, WI 54619

608-625-4123

*PV Powered since 1980*



In central California, near Fresno, since 1983

- \* full line of PV equipment
- \* competitive prices
- \* personal service & support
- \* personal experience
- \* system design
- \* on site service
- \* installations
- \* free newsletter

### ALL DAY PV WORKSHOPS - \$35

### Call for next date

Don and Cynthia Lowebug

PO Box 231

North Fork, CA 93643 • (209) 877-7080

12 VOLT  
PRODUCTS

## RADIO

C. CRANE CO.

147 Watson Lane

Fortuna, CA 95540

800-522-TUNE(8863)

or 707-725-5940



- Antenna boosters which dramatically improve AM, FM, SW & scanner reception.
- Radios/Receivers/Scanners/Accessories.
- New! AM/FM Auto antenna, easy to install.
- Experience and service to help you decide which products are best for you.
- Free in-depth information available.

SELECT-A-TENNA, SANGEAN, GRUNDIG, PROTON, UNIDEN, TERK TECHNOLOGIES, CHANNEL MASTER, MCKAY DYMEK, BARKER AND WILLIAMSON

# Power to the People- Load Circuits

John Wiles

**L**oad circuits in any power system are among the most critical in terms of safety because the casual, sometimes uninformed user has unrestricted access to them. "Power too cheap to meter" and the ubiquitous ac outlet have lulled many into a false sense of security which may not be warranted in our alternate energy systems. Alternating-current systems are installed with standardized wiring methods, standardized junction boxes and outlets, and appliances with standardized cords and plugs -- all tested and listed by Underwriters Laboratories (UL). Can we say the same about our PV systems?

To minimize safety hazards in PV and other alternate-energy load circuits, particular attention should be paid to the National Electric Code (NEC) which applies to both ac and dc power systems. Load circuits start at the battery and run to the outlet receptacle or to the appliance if directly wired. In Code Corner in Home Power #21 and previous issues, the dc load center with circuit breakers was discussed. Because of the importance of protecting the load circuits from short circuits, current-limiting fuses must again be addressed and stressed.

## First -- Limit That Short-Circuit Current

Battery banks have the potential of delivering far higher currents into a short circuit than does the typical ac residential power system. Normal hardware store variety fuses and circuit breakers (even Square D QO breakers) do not have the ability to withstand or interrupt these high short-circuit currents. Special, high-interrupt circuit breakers are available which can be used, but price, availability, and ease of use probably makes them only practical for the battery-to-inverter circuit (See Code Corner - HP #21). In all other circuits some method must be used to limit the available short-circuit currents from the battery since either low-cost fuses or circuit breakers will be used for the overcurrent protection.

Standard fuses, either slow-blow, time-delay fuses or the fast-acting fuses, do not open fast enough under short-circuit conditions to significantly reduce or limit the high currents before they can do damage to other down-stream fuses, circuit breakers, and switches. A special current-limiting fuse must be used that does open fast enough under short-circuit conditions to significantly reduce or limit the very high peak currents. These fuses have industry generic designations of RK-1 or RK-5 among others. Most manufacturers make these in fast-blow and slow-blow configurations which refer to the overcurrent function, not the short-circuit function. Manufacturers who have dc ratings on these fuses, like

Littelfuse Inc., have had them tested by UL. The dc rating is usually half the ac voltage rating and one tenth (10%) the ac interrupt current rating. Some manufacturers don't have dc ratings or UL dc listing on these fuses and if it doesn't say current limiting and dc, it may not provide full system protection. Let the buyer beware!

## Next -- Use the Proper Wiring Method

With the circuit protected from overloads (fuses or circuit breakers) and short circuits (special circuit breakers or current-limiting fuses), care must be taken to use wiring methods that will minimize the use of these safety devices. These methods are specified in the NEC and are used daily by electricians on ac systems. In many cases, alternate energy systems will be wired using non-metallic cable concealed in walls or otherwise protected. PVC electrical conduit containing individual wires is also a possibility. Other methods are available and the local electrical codes may require electrical metallic conduit.

Separate conductors, either exposed or concealed in walls, are not allowed by the NEC and pose a very real hazard. Separate conductors do not have the necessary mechanical protection (from rats, nails, feet, etc) nor the electrical insulation (from heat, other conductors, or grounded surfaces) that is required of NEC approved wiring methods. These constraints apply to battery cables as well as load circuits.

Number 10 AWG is a wire size commonly used for low-voltage branch and load circuits. In the form of 12-2 with ground, nonmetallic cable (type NM), it is reasonably priced at building supply stores and minimizes voltage drop when compared to smaller sizes. Unfortunately it is a little more difficult to work with and it is hard to attach to some receptacles and switches. These devices are frequently sized for number 12 AWG or smaller wire. If voltage drop calculations allow, number 12 AWG conductors might be used for general lighting circuits with

up to 4-5 amps load (40+ watts -- pretty bright). Appliances using more current could be direct wired using a wall mounted junction box, the appropriate flexible cable, and an appliance mounted junction box.

Also large conductor cables could be used as feeders and then spliced to smaller conductor cables near the end use appliances. All splices must be made using an approved method and placed in an approved junction box. In this case, the overcurrent protection must be sized to protect the smallest conductor in the circuit. For example a number 8 AWG feeder connected to a number 12 AWG lighting circuit must have no larger than a 20 amp overcurrent protective device to protect the number 12 AWG wire.

An exception to this is that a short (less than 18 inches) "pigtail" of number 12 AWG could be attached (with an approved splicing device or method) to a number 10 AWG cable and the combination protected for the 30 amp rating of the number 10 conductor. The splice would have to be made in an approved outlet or junction box, but this technique will allow easier connection to the receptacles. Incidentally, Article 720 of the NEC says that number 12 AWG conductors are the smallest that can be used on ac or dc systems operating at less than 50 volts.

The NEC requires that each service (ac, dc, high-voltage, low-voltage) in a building or residence have non-interchangeable receptacles and plugs for portable loads.

#### **Last -- Power To The Load**

The demand in the PV industry is insufficient to have a separate, UL listed plug and receptacle developed and marketed. It is up to the dealer/installer or homeowner to choose an appropriate device. Since the NEC requires a grounding conductor on each receptacle for use with appliances that might have metal exterior surfaces, three bladed plug/receptacle devices will be needed whether the system is grounded or not. There is a standard 28-volt, 30-amp, dc UL listed specification-grade, twist-lock plug and receptacle which could be used. It has a NEMA (National Electrical Manufacturers Association) designation of FSL1, is large like an electric range plug, costs about \$15 per piece (i.e. \$15 for the plug and \$15 for the receptacle), and is manufactured in limited quantities.

Another choice might be a 125-volt 15 or 20-amp, 3 blade twist-lock device that is sold in many hardware stores at a reasonable cost (\$3-6 each). Do not use a standard 125-volt receptacle because someone might plug a 125-volt appliance into the 12-volt circuit. If a 240-volt power system is not used in the residence, 240-volt devices could be used for the 12 or 24-volt dc

requirement. Incidentally, if both 12 and 24-volt circuits are used, the use of the grounding blade or the grounding conductor for a common negative conductor is not approved. In each case, it appears that better performance (lower voltage drop and longer life) will be realized if specification grade (SPEC stamped on the device) devices are used rather than the lower quality standard grade of devices. All of these devices, if not available locally, may be special ordered from electrical supply houses.

#### **Access**

Author: John Wiles, Southwest Technology Development Institute, New Mexico State University, POB 30001/Dept 3SOL, Las Cruces, NM 88003 • 505-646-6105

Littelfuse, Inc. 800 E. Northwest Highway, Des Plaines, IL 60016 • 800-TEC-FUSE

FSL1 Receptacles and Plugs: Bryant Electric, Milford Place Corp. Center, Milford CT 06460 • 203-876-3600

National Electric Code, National Fire Protection Assoc., Batterymarch Park, Quincy, MA 02269 • 800-344-3555

The Photovoltaic Answer Book, The source of the Code Corner articles. See advertisement below.



SWRES  
AD



# Things we can do without!

U.R. Riptoff

*The following letter arrived with a "plug it in" air freshener.*

Dear Home Power,

How about a test of the enclosed product? Could I run these on an inverter? How many PV panels would it take? How many batteries? How about a windmill?

Do you know if they make a 12 volt model? If not, why not? I'm thinking of disconnecting my power lines, but I need more info first before I commit to Alternative Energy.

Sincerely, Tom Simko

PS Okay, I'm just kidding! But, how about an occasional column on junk like this? It could be called "Things that we can do without." This gets my vote for most superfluous. Up here (6000 feet elevation), they graze cattle on "mountain meadows". Hope this doesn't smell like cowpies!

*Well Tom, never let it be said that the HP crew are playing with a full deck. To prove it, and because you asked for it, and because it's April, please welcome...*

♪♪ Plug it in, Plug it in ♪♪

with "Mountain Meadow" fragrance

## The Product

This air freshener is billed as "the long lasting refillable air freshener that plugs into an electrical outlet. It gently warms its fragrance refill for 30 days of freshening and constant odor protection." Uh huh.

## Packaging and Documentation

The unit arrived via mail from Mr. Simco with the original packaging intact. The package, a heavily clay-coated thick paper, proudly displayed the "recyclable" symbol on the back. Using the symbol on the package gives the idea that these folks are environmentally concerned. Ain't advertising grand?

The documentation is plainly written and contains step by step drawings showing that this product poses no threat to long fingernails during installation. In fine print, we find the following: "CAUTION: Do not remove or puncture clear film covering gel."....."If irritation persists, consult a physician. Keep out of children's reach. Do not place open refills on finished wood surfaces." Wonderful.

## Test Environment

We installed the air freshener in a typical RE powered home setting. Power was provided by PV modules and the unit was sourced by a 2KW high efficiency inverter found in many, if not most, RE homes. All electrical measurements were made by a highly accurate Fluke 87 DMM. Olfactory impressions were recorded by the occupants of the house, including the dog.

## Installation and Operation

The unit was easily installed. We slowly removed the foil covering from the "fragrance" packet. After reading the CAUTION, we were careful not to get any on us. We plugged it in and left the house for about twenty minutes while the unit warmed up before taking measurements. Big mistake. The smell that confronted us on our return was anything but reminiscent of mountain meadows. We would have preferred the cowpies, at least we would have had some idea of the origin of the odor. Other smells, er, fragrances are available. We opened all of the windows and the door in the room while we took the readings. While we were doing this, the dog came into the house to investigate the new "open door policy". One sniff, two, then she turned tail and headed for parts unknown. We recorded her vote.

## Cost

The purchase price is a few bucks, we guess. Since the item was sent in, we didn't bother to inquire. Frankly, we don't care what it costs to purchase it, the real cost is the consequences of using it. The graph shows this little item's power consumption.

The real cost is not in dollars here, but in environmental damage due to wasted electric power. If even 10% of America's homes were to plug it in, then we're looking at

|                     |                 |                      |
|---------------------|-----------------|----------------------|
| Line Voltage        | <u>120.2</u>    | volts rms            |
| Current             | <u>0.01263</u>  | amps                 |
| Power Consumption   | <u>1.518</u>    | watts                |
| Daily Consumption   | <u>36.435</u>   | watt-hours per day   |
| Monthly Consumption | <u>1108.23</u>  | watt-hours per month |
| Yearly Consumption  | <u>13298.78</u> | watt-hours per year  |

10 million watts of power, or 93 billion watt-hours yearly.

### Conclusions

If you aren't part of the solution, you're part of the problem.

♪♪ Phantom Load, Phantom Load ♪♪

Got no place in my abode  
Waste of power, there's no doubt,  
It's a thing we can all do without,  
Throw it out, throw it out!

### Access

U.R.Riptoff is the nom de plume of a frequent HP contributor and RE user in the State of Jefferson. He can be reached by writing to him c/o Home Power, POB 130.

*Thinking solar? Bah!*

What you need is a Lil Nukie!  
The 1st and Only Residential Reactor!  
The Lil Nukie is a mostly contained  
nuclear home power system.

*Just check out these features:*

- Built-in nightlight!
- Extra long extension cord!
- U-cut lead shielding-fits most applications!
- NRC application forms included!
- Complete installation, operation, and evacuation manual included on CD ROM. (48 disk set).
- Optional water heater interface kit available.
- 10% discount for Home Power readers thru April 1st.

*Available From:*

**GlowInTheDark**  
**Corporation**  
**555 Fooldja Circle**  
**Sucker, NV**

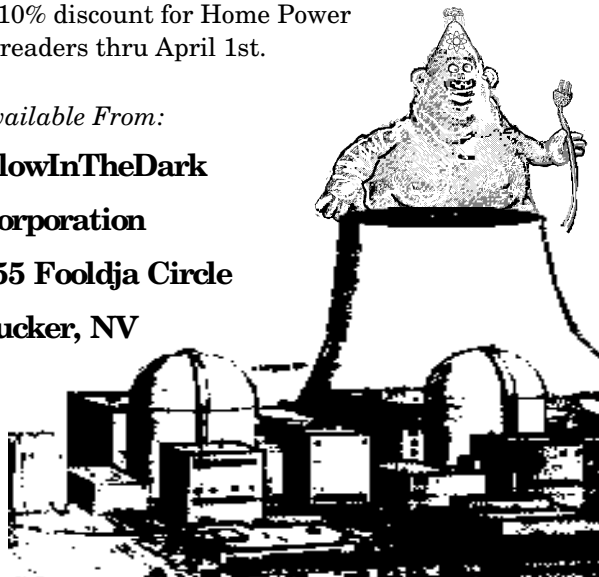

## Home & Heart

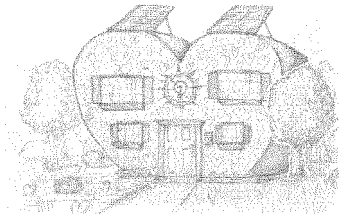

Kathleen Jarschke-Schultze

There are misconceptions about country living with renewable energy. This prompted me to start this forum for questions and answers about the homemaker's role. My own introduction to living with renewable energy was abrupt and complete. In the last six years, I have lived on micro-hydro and solar power. Each system has its own characteristics.

### Introductions

I am a mail-order bride. Of course, this is a simplistic statement. Although my husband-to-be and I had never met, we began writing to each other at the urging of a mutual friend. After a whirlwind literary courtship I ventured to the mountains to meet Bob-O. I never left. A year later we were married. Until then I was a city girl. I was born in San Francisco and spent my life in the Bay Area.

### Marginally Mountain

At first, living out in the woods, with no phone, no indoor toilet, but with hydro-powered electricity, was like camping out. When I walked outside in the morning I was surrounded by the forest. The smoke from the wood stove, the smell of the trees, brought back memories of childhood camping trips.

As the practicalities of country living became a day to day awareness, Bob-O began to tell me that I was marginally mountain. I had a good grounding in the common sense basics of renewable energy living from my father, although he didn't know it. He taught us to turn off lights when we left a room. If you aren't using an electrical device, don't leave it turned on. Long before recycling was popular he taught us to separate our garbage. I guess that's why Bob-O granted me a margin.

### Realities

Because Bob-O's work then kept him away from the cabin for lengths of time, I had a crash course in micro-hydro. I learned how to clean the intake of forest debris, how to reset the alternator, and how to check the batteries. Most importantly, I learned how to check the nozzle for plugging at the wheel BEFORE climbing the mountain to check the head.

Walking along our water ditch, with a rake/ho, cleaning the length up and then down, there was a large madrone with bear claw marks on it at about my eye level (I'm 5'10"). At first this made me very nervous to go up there alone, but I never did see a bear there.

There was wild life everywhere. Deer eating my garden, ringtails raiding the porch, raccoons and squirrels getting into the chicken feed, bears in the apple trees in fall, civit cats and skunks, and once a cougar came into the yard and snatched one of my free ranging chickens. I came to have a special fondness for a garter snake that roamed our cabin freely, looking for mice.

### Washing Machines

The first washing machine I used there was a wringer with a Briggs and Stratton gas engine on it. I learned to check the oil and gas before I did the laundry. My stepdaughter was always better at pulling the starter cord than I was though. It sat outside under some oak trees. It was a pleasant place to be in the summer. The winter, however, was a different matter. I told Bob-O that the water was just too damn cold to put my hands into in the winter. He sympathized. A couple of weeks later he surprised me with elbow-length, flannel-lined, rubber gloves. A couple of weeks later, I bought an automatic washer.

It was a used, rebuilt Whirlpool. I loved it. We had to run the generator to use it but I didn't care. Later when we sold our Triplite inverter and got a Trace 2012 I could use the washer off that. From talking to other people on renewables the only washer that doesn't work well on inverter power is the Maytag. Whirlpools do have a rinse cycle that needs a certain amount of water pressure, but I never had a problem with that.

After moving to our PV powered home, I learned to time my wash to one load per sunny day, when the panels' input was at their highest. Living with renewables is a matter of timing to nature, wind, water, and sun. When I lived on micro-hydro I could vacuum pretty much anytime. Now that I live on solar, when the sun shines all morning, I open the doors and windows, shake out the rugs and cushions, and vacuum the carpet.

### T and A

Living on renewables is a matter of Timing and Awareness. You choose your own degree of sophistication. I use my food processor almost every day and the microwave every two or three days. Bob-O and I are both on our computers for hours every day. We watch TV almost every night. I don't feel as if I am missing out on any comfort I might want. Bob-O says now that I am 'more or less mountain'. Wow, am I impressed.

### Vacuum Cleaners

I have a small Hoover PortaPower QS vacuum now. In the old cabin that was enough. Now I am faced with a large expanse of wall-to-wall carpet and I want to upgrade. My neighbor has a Contractors Shop Vac (wet/dry), but he also has wood floors. I want to hear from some homemakers out there, living on renewables about their vacuums, good and bad.

Let's share this information. Housekeeping is a thankless job. No one notices if you do it, only if you do not. Anything that makes it easier or faster is a blessing. Consider this column the Heloise of Home Power.

### Access

Kathleen Jarschke-Schultze, C/O Home Power, POB 130, Hornbrook, CA 96044 • 916-475-3401.



## END DEAD BATTERY FRUSTRATION

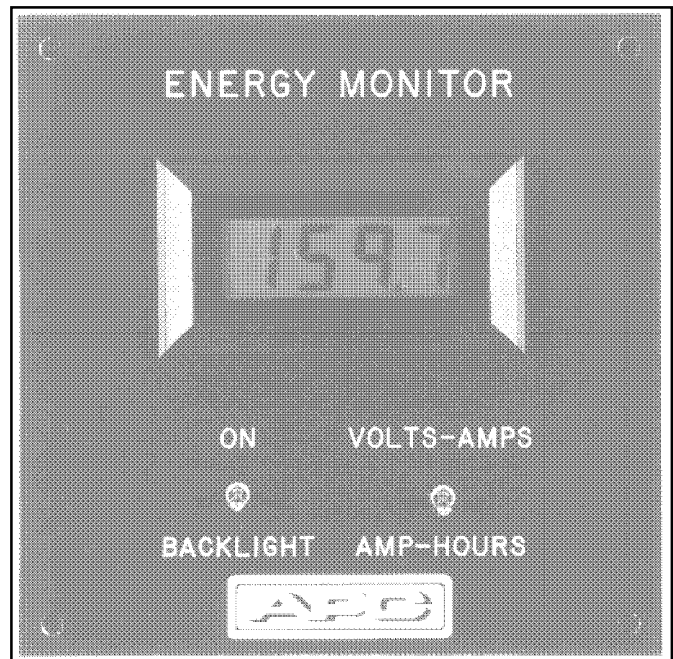

**\$299.00 Includes 400 Amp Shunt**

The new Energy Monitor provides information necessary to extend daily capacity and battery life. It measures Volts, Amps, and Amp hours. One model works on 12/24 Volt systems to 400 Amps and 2000 Amp hours. Resolution of 0.1 Amp covers sensitive loads. End the frustration of dead batteries and constant replacement... triumph over evil with the Energy Monitor from Ample Power Company

**AMPLE POWER COMPANY**



800-541-7789

206-789-5758

1150 N.W. 52nd Street • Seattle, WA 98107



# Homebrew

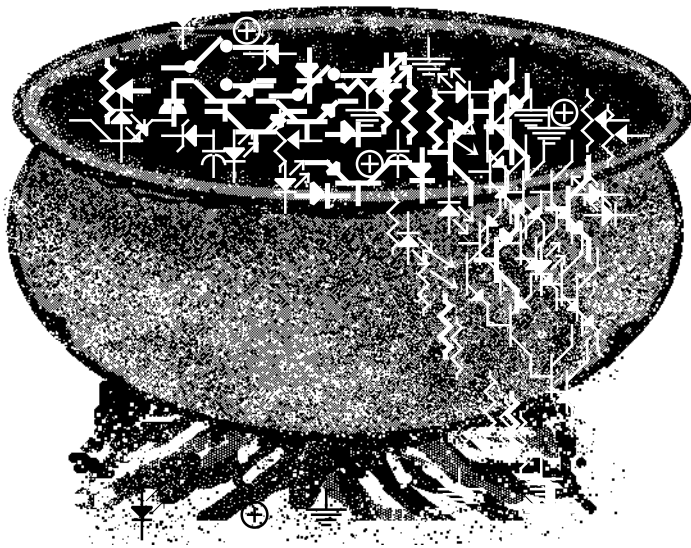

## Hacking with the RENAIR Battery Charge Control Panel

Bob-O Schultze-KG6MM

From time to time Home Power gets letters from folks with 24VDC systems bemoaning the fact that most of the DC appliances and controls available on the market are geared toward 12V systems. Well, listen up folks! This one's for you!

God knows what sort of military machinery this panel was part of, but it originally ran on 24VDC. This charge control panel is just what it says it is, a panel with controls and instrumentation for starting, monitoring, and adjusting a 24V engine-driven (probably diesel) generator or alternator. Almost all of the components can be used on 12 VDC.

### Here's what you get:

- A nice 50 mV. @150 Ampere brass shunt with matching 150 Amp full-scale Crompton analog ammeter.
- A 0 to 40 VDC full-scale Crompton analog voltmeter, 2-ganged Heinemann 110 Amp @ 28VDC circuit breakers.
- A manual reset 2 Amp DC circuit breaker.
- A Hobbs hourmeter reading 0000.0. Since the Hobbs is not resettable, this is the surest indication that the whole shebang is brand new. The hourmeter works on 6 VDC to 40 VDC.
- 1-Ohmite 10K $\Omega$ , 2 Watt potentiometer with a large knob.

- 3-Bosch 10/20A, Automatic resetting circuit breakers.
- 2-SPST toggle switches-heavy metal
- 1-SPDT toggle switch
- 1-SPST momentary with a big red button marked "STOP"
- 1-DPST momentary w/big green button marked "START"
- Two cool-looking chrome panel lights-shielded on top
- A big green bezel "Power On" light-oooh,oooh!
- A full-wave bridge rectifier and 6800uF @40V capacitor
- A "Fault Indicator" circuit board. This outputs to several small lights on the panel marked low fuel, water in fuel, low oil pressure, etc.
- A cast of seemingly hundreds of white (yes,all of them) wires with little make-you-go-blind numbers on them hooking the whole thing together.
- A heavy box about 17" X 10" X 4" with hinged front. All the meters, switches, lights, etc. are mounted on the hinged front.

All this is of the highest quality; just what you'd expect when the government is spending our tax bucks. All kinda nice stuff and a welcome addition to any hackers junque box, but if you really want to set up a 24V engine/alternator battery charger, whew! It's the kind. Here's how.

A schematic for the Mark VI 12V alternator field controller was first published in Home Power #2. The schematic that follows is a 24V version of that circuit.

First,THE DISCLAIMER- This is what I did to make the control panel that I had work. I'm guessing that all of them come from the same batch and are wired the same. After all, this stuff is military surplus so anything is possible. Check to see that all the wires go the same places that this one did. In the interest of safety and sanity, disconnect and remove any that you're not going to use or aren't sure of, OK?

Remove the 10K $\Omega$  Voltage Adjust potentiometer from the panel and replace it with a 1K $\Omega$  linear taper pot. The knob should work fine. It will become R7 of the Mark VI. Remove the SPST toggle marked "Preheat" and replace it with a 100K $\Omega$  linear taper pot. It becomes R3.

The Heinemann breaker is set up to break both the positive and the negative battery-to-alternator lines. If you look at the back of the insulator, you'll notice that there are "+" marks on both terminals of one of the breakers and "-" marks on both terminals of the other. Bring your positive and negative leads in from the battery bank to the bottoms or "load" sides of the breaker.

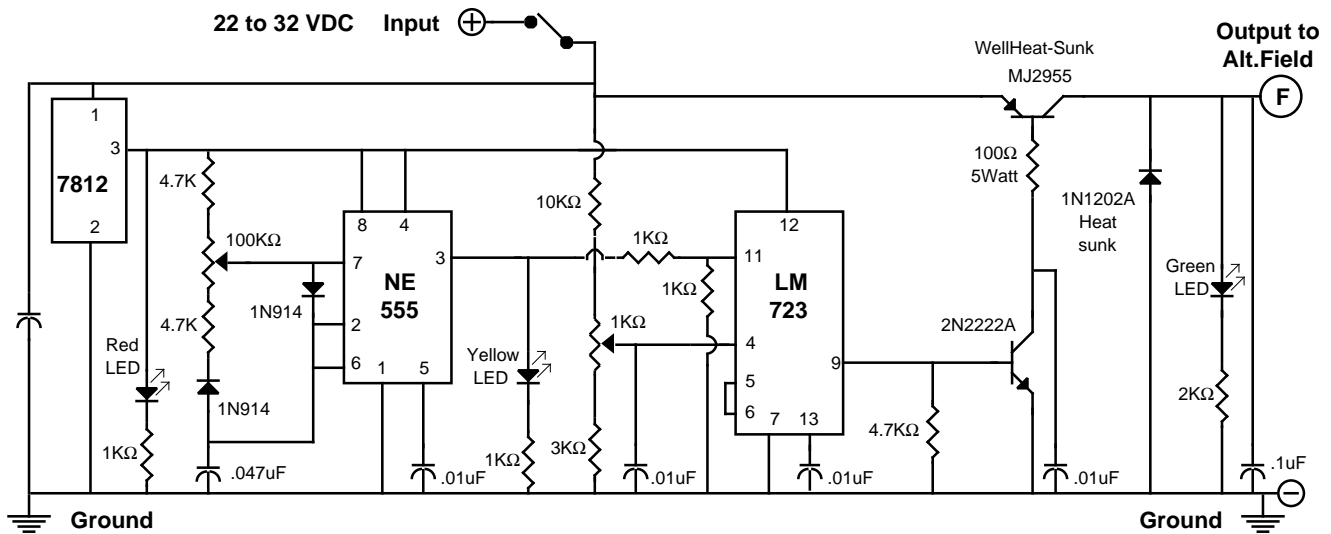

Remember that these wires will be carrying the full output of your alternator, so size them accordingly. All the seething mass of white wires should be on the tops or "line" sides of the breakers. If any aren't, put them up there, keeping the negatives with the negatives and the positives with the positives. Your Mark VI input wires go here also. The negative wire coming from your alternator goes to the top or "line" side of the negative breaker and the positive wire from the alternator connects to the lower side of the 50MV shunt. Connect the output wire of the Mark VI to the alternator field. Trace out (good luck!) or remove the wire from the upper side of the "Panel Lights" switch and connect a wire from there to the lower side of the shunt.

Assuming that you've been living right and haven't angered to gods in some way, throwing the big breaker switch to "on" should activate the Mark VI, the volt and amp meters, the hourmeter, and the big green "Power On" light. Alright! Toggling the panel lights switch up should turn them on. The "voltage adjust" pot will control the upper charge voltage set point and the other pot will control the alternator amperage output rate.

Have Fun!

#### Access

Author: Bob-O Schultze is the hacker and hydromanic found at Electron Connection/ Lil Otto Hydroworks!, POB 203, Hornbrook, CA 96044. • 916-475-3401.

The Battery Charge Control Panel is available from Renavair Corp. POB 2110, Alpine, CA 92001 • 619-445-7317. A complete panel is \$119.95. The panel box without any components is \$19.95. Most components are available separately.



RENAVAIR  
AD

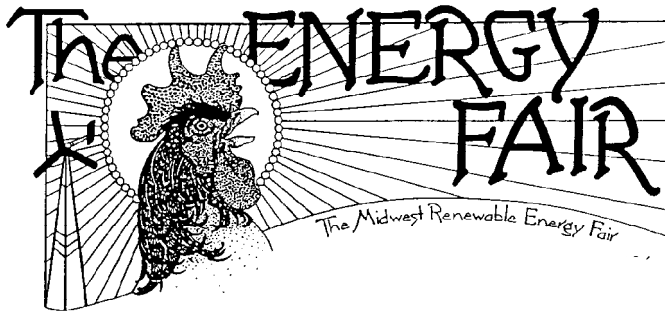

## Schedule of Events

### Friday June 21, 1991

9:00 Fair opens to public-exhibit booths, displays, demo house, food booths, electric and solar vehicles, and children's activities. 10:30 to 6:30, on going one hour workshops

5:30-6:30 RENEW Steering Committee Meeting

6:30 Speaker

8:00 Evening Entertainment

### Saturday, June 22, 1991

9:00 Fair opens to public-exhibit booths, displays, demo house, food booths, electric and solar vehicles, and children's activities. 9:30 to 6:00, on going one hour workshops

6:30 Speaker

8:00 Evening Entertainment

### Sunday, June 23, 1991

10:00 Fair opens to public-exhibit booths, displays, demo house, food booths, electric and solar vehicles, and children's activities. 10:30 to 5:30, on going one hour workshops

6:00 Fair closes

The Midwest Renewable Energy Association Fair will again be powered by PV and wind systems.

Admissions: Daily Admission: \$3\*, Weekend Pass: \$6\*, Evening Concerts: \$5/night. Children under 12: Free\* \*does not include evening concerts. T-shirts will be available on the fairgrounds for \$14.

Midwest Renewable Energy Association memberships are available for \$25. Included in a membership are a T-shirt, admission to the Fair, and Quarterly Newsletter.

### Display Booths

Display Booths are available for manufacturers, dealers, and cottage industries to sell and promote renewable energy and energy conservation services.

Rates: Manufacturers/distributors \$500, Dealers/cottage industries \$200, & Non-profit, tax exempt organizations \$50.

## The Midwest Renewable Energy Fair

Information: If you would like more information on exhibiting or attending, contact us at 715-824-5166 or write to Midwest Renewable Energy Association, 116 Cross St., Amherst, WI 54406

### Workshops

1. Home-size Wind Systems: Mick Sagrillo, Lake MI Wind & Sun, Forestville, WI
2. The Physics of Solar Cells and Recent Innovation: Dr. Richard Komp, Maine Solar Energy Assn., Addison, ME
3. Energy Efficient Lighting: Gunars Petersons, Alternative Power & Light, Cashton, WI
4. Home-sized Hydroelectric Systems: Don Harris, Harris Hydroelectric, Davenport, CA
5. PV for Educators-Solar Electric Education Kits: Sonia Vogl, Oregon, IL
6. Solar Ovens-How to Build and Use Them: Julie Wurl-Koth, Solar Spectrum, Tomahawk, WI
7. PV/Wind Hybrid Systems: Dr. Richard Komp
8. Energy, Economics, and the Environment: Dr. Larry Smith, University of WI, Green Bay, WI and Bill Hurrell, Community Builders, Green Bay, WI
9. Solar Energy and International Development-The Pan-American Health Organization: Ken Olson, Solar Technology Institute, Carbondale, CO
10. Superinsulation-The Enercept Homes: Pat O'Brien, O'Brien Construction, Manawa, WI
11. Batteries: Richard Perez, Home Power Magazine, Hornbrook, CA
12. Fundamentals of Energy, Electricity, and Electronics: Spark Burmaster, Apro Tec Energy Management, Chaseburg, WI
13. PV/Hot Water Hybrid Solar Systems: Dr. Richard Komp
14. Pyrolysis Cogeneration-An Alternative for Producing Electricity Without Incineration: Dillon McMullen, PY-CO-GEN, Irma, WI
15. Solar Water Pumping-Applications, Design, and Installation: Mike Horan, Solar Jack, Safford, AZ
16. Intro to PV Systems-Basic System Descriptions & Design Considerations: Bob Ramlow, Snowbelt Solar, Amherst, WI, & Jim Kerball, PV Systems Co., Amherst, WI
17. Innovative Renewable Energy Applications for Home Owners and Communities: Dr. Sonia Vogl and Dr. Robert Vogl
18. PV and Wind Applications for Developing Countries: Lane Garrett, Sunamp Power Co., Scottsdale, AZ
19. Construction Techniques for Superinsulation: Mark Klein, Gimme Shelter, Almond, WI
20. Planning for Remote Home Power Systems: Steve Willey, Backwoods Solar Electric Systems, Sandpoint, ID
21. Farm and Residential Water Systems: Spark Burmaster
22. How to Organize and Run a Home Business: Karen Perez, Home Power Magazine, Hornbrook, CA
23. Advanced PV Systems-Components, System Configurations and Sizing, Bob Ramlow and Jim Kerball



Left: One of the electric vehicles at last year's Midwest Renewable Energy Fair. During the 1990 MREF, thousands of people visited, learned, and enjoyed each other's company. This year's fair promises to be bigger and better than ever!

## Energy Fairs

24. Inverters-A Home Power Users Guide: Richard Perez
25. Solar domestic Hot Water Systems: Allen Curtis, Auer Steel and Heating Supply Co., Milwaukee, WI
26. Alternative Energy in Europe-What Our Economic Competitors are Accomplishing with Renewables: Steve Smiley, Bay Energy Services, Traverse City, MI
27. Electromagnetic Pollution: Spark Burmaster
28. Air/Water Combination Solar Systems: David Lankheet, Controlled Systems, Wayland, MI
29. Utility Conservation Programs and Home Energy audits: Jack Bohman, Wisconsin Power & Light, Iola, WI
30. Site Analysis for Renewables: Richard Perez, Don Harris, and Mick Sagrillo
31. Air to Air Heat Exchangers: Doug Steege and Chuck Gates, Altech Energy, Madison, WI
32. Solar Water Pumping-Principles and Products: Windy Dankoff, Flowlight Solar Power, Inc., Espanola, NM
33. POWER-Promoting Options for Wise Energy Regulations, Panel Discussion, Amherst, WI
34. Sunseeker: Design, Construction, and Racing of a Solar Powered Vehicle for the GMC Sunrayce: Jeremy Berg, Jordan Energy Institute, Grand Rapids, MI
35. Community Environmental Activism: Waring Fincke, Wisconsin, Milwaukee, WI
36. Do-It-Yourself Solar Air Collectors: Darryl Thayer
38. Passive Solar Architecture: Ken Woods, Illinois Solar Energy Society, Naperville, IL
39. Intro to Sustainable Agriculture: Prescott Berg, Four Winds Farm Supply, River Falls, WI
40. Energy and Economics of Sustainable Agriculture-An Advanced Conversation: Prescott Berg
41. Small Scale Hydrogen Production: Jim Sievers, Iowa Alternative Energy, Cedar Rapids, IA
42. Groundwater Pumps for Heating and Cooling: Neal Loehrke, Valley Well Drilling, Weyauwega, WI
43. Solar Air Collectors: Al Schockmoehl, GS Energy, Des Moines, IA
44. Efficient water Use in the Home-Conservation Made Easy: BJ Welling, Snowbelt Solar, Amherst, WI
45. Living with a Solar Greenhouse: Claire Kerball, Amherst, WI
46. How to Design and Build a Wood Gasifier for Vehicular Use or Cogeneration: Vern Ader, Midstate Technical College, Marshfield, WI
47. RENEW-Encouraging Renewable Energy Development and Use in Wisconsin: Don Wickert, Wisconsin Energy Bureau, Madison, WI
48. Sterling Engine-Electricity from Solar & Biomass: William Beale, Sunpower, Inc., Athens, OH
49. A New Generation of Wood Stoves: Gerard Hemmes, Vermont Castings, Grand Rapids, MI
50. Recycling and Repowering a Conventional Car into an Electric Vehicle: Ray Oviyach, Fox Valley Electric Auto Assoc., Oak Park, IL
51. Building a Hybrid Electric Vehicle: Bill Shafer, Fox Valley Electric Auto Assoc., Oak Park, IL



# SEER '91

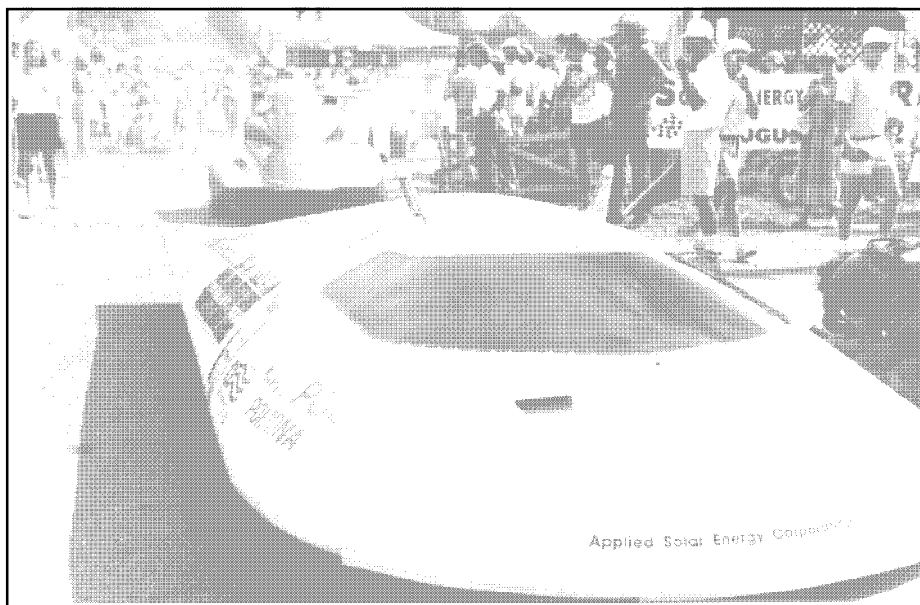

Above: The start of the 1990 Tour de Mendo at SEER '90.

## SOLAR ENERGY EXPO & RALLY

August 9, 10, & 11, 1991 • Willits, California

You are invited to the Solar Capitol of the World for the Second Annual Solar Expo. Last year's show was a tremendous success and this years promises to be even better.

**NEW FOR 1991**  
**Industry Day**- August 9th. - For much needed networking & strategic planning for the future of renewable energy & conservation technologies.

**National "Off The Grid Day"** - August 10th, sponsored by Real Goods. Join in a nationwide effort to unplug from the grid for a day in support of alternative energy at SEER '91, National Media expected.

**Declaration Of Energy Independence** - Be among the signers to put your "John Hancock" on the "Declaration" to contribute to the drafting of a REAL National Energy Plan to be presented to the US Congress.

**Solar Electric Summer** - Starting with the kick-off of the Stanford Solar Car Race in Sacramento, June 18 to the Bay Area and Los Angeles; then on to the Clean Air Revival in San Francisco, August 3 & 4 for the semi-finals of the Electrathon Cup Challenge & culminating in the Solar Capitol, at SEER '91 August 10 & 11, with the Grand Finals for Solar Cars and the Electrathon vehicles.

**New SEER Office:** We now have a permanent office in the Solar Capitol at the Willits Chamber of Commerce - our main sponsor! Please make note of the new address:

SEER '91  
239 South Main Street, Willits, CA 95490  
telephone: 707-459-1256

**Calling All Cars** - If you want to enter a vehicle in the "Tour de Mendo" Rally call Phil Jergensen at 707-459-1256

**Exhibitors** - New info packs soon. For now please send us any suggestions you have for making SEER '91 even more successful.

**Testimonials From Seer '90**

"It was an incredible experience - in fact it changed my life. Never before have I seen so many people in one place sharing positive ideas about solutions to the problems of the world." Jack West, Humboldt State University, Arcata, CA

"It was a fantastic Solar Energy Expo & Rally (SEER '90), a total success for a small community, Willits did it up first class. My compliments to those who did the nuts & bolts." Larilani Greenly, Sunshine Systems, Grass Valley, CA

"Congratulations and thank you! A great SEER '90 weekend! I had a great time & made some very promising business contacts." Doug Brown, Echo Solar Electric, Echo Lake, CA

"Thanks for all the planning & organizing effort that made the energy fair such a success. For me it was one of the highlights of the year. A real "kick in the pants" to solar projects. Please do it again next year." Dave Keniston, Arcata, CA

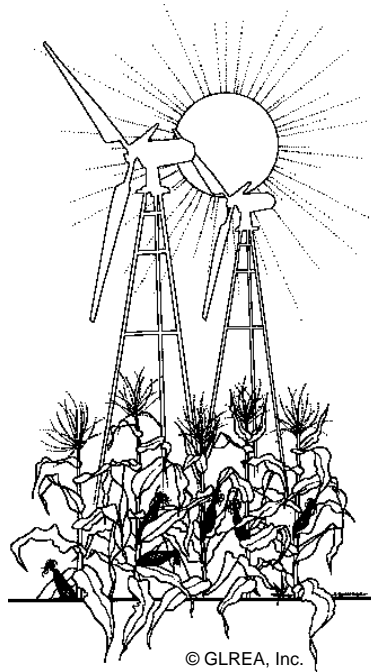
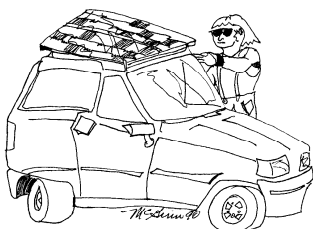

Inspired by the wonderful example of the Midwest Renewable Energy Fair in Amherst, Wisconsin, and noting that many of the participants were from Michigan, several of the attendees of MREF began planning soon thereafter for the first Great Lakes Renewable Energy Fair (GLREF). After resolving organizational structural details (The Great Lakes Renewable Energy Association, Inc., is applying for federal non-profit as well as state charitable corporation status), we have begun the logistical journey toward a July 19, 20, 21, 1991 fair date.

The site is the Northwestern Michigan Fairgrounds located just eight miles south of Traverse City, Michigan. Traverse City is a favored resort destination for both the Detroit and Chicago areas. The fairgrounds site allows us to offer camping to both exhibitors and attendees; a prime consideration to us.

We hope to offer many of the same activities as MREF and a few of our own. We live in an area where it is alleged that "you can't do alternative energy here." You might imagine that this comes as quite a shock to Sarah Jane Johnson and (Kap'n) Kerry Krçek, Julia and John Brabenec, Maggie and Duncan Sprattmoran, Sue Kopka, Tim Johnson and others who live comfortably with wind, solar and both. We will conduct tours by bus to some of these homes to show people what is possible.

We will offer "proceedings" of the Fair, as well. Synopses of workshops, sharings of personal experiences of the Fair, photography, drawings and papers submitted for publication will all be

# Great Lakes Renewable Energy Fair

July 19, 20, 21, 1991

Northwestern Michigan

Fairgrounds

Traverse City, Michigan

considered. This article also serves as our first call for papers with scientific or engineering merit.

We are in the process of seeking exhibitors, workshop leaders, panel discussionists and speakers to fill out our roster. If you or someone you know is interested in attending this event and filling one or more of the above roles, please contact us.

We debated the breadth of offerings for the Fair at length: Should we get GM up here with their brand new "nukesaver" electric car to draw more mainstream folks? Should we invite the local community-owned coal- and woodchip-burning utility? Will Consumers Power give us some hints on conservation measures that people not quite ready to commit to renewables could use? Can state government be of any use? Join us in July to see how it worked out!

We are very excited by the prospect of the Fair! The recent Persian Gulf situation and the unveiling of the Bush Administration Energy (non)Policy heightened interest of both the GLREF coordinating committee and the general public. We would also like to thank the MREF and Home Power for their encouragement and for demonstrating that information, like manure, is useless until spread around.

**Access:** Phil Thiel, Secretary, GLREA, 11059 Bright Road, Maple City, MI 49664 • 616-228-7159.



## Bellevue Community College Alternative Energy Symposium & Fair June 8, 1991 • Bellevue, Washington

This event will introduce the general public to exciting and practical energy generating and saving technologies and their current application. Learn how you can generate your own power through solar (photovoltaics), wind and microhydro for your home, business, transportation and recreation. Several electrical (including solar assisted) and human-powered vehicles will be on display.

Find out how, with the help of existing methods, designs, products and services, you can reduce your dependence on non-renewable and polluting fuels and instead conserve energy and preserve a sustainable environment for future generations. Come for a full day of how-to

workshops, stimulating seminars, product demonstrations and sales, a play, music, networking, food (some prepared on solar-cookers) and fun!

Bellevue is within easy bicycling, bussing, or driving distance just east of Seattle, WA. Plan to attend - contact us for a brochure! We also welcome enquires and support from individuals, businesses, organizations and municipalities interested in becoming FAIR sponsors or to participate as presenters or vendors. Contact: Olof Sundin, FAIR Coordinator, J-121, Bellevue Community College, 3000 Landerholm Circle SE, Bellevue, WA 98007-6484, • 206-641-2012.



## MicroHydro Specialists

10+ yrs. living on & with MicroHydro  
Makers of 'Lil Otto' Hydroelectric  
Systems

*"He's a hard worker who doesn't  
drink very much!"*

Lil Otto is a permanent magnet hydroelectric generator. He works with as little

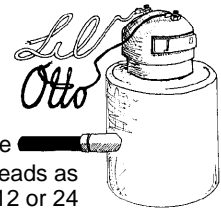

as 1.2 GPM or Heads as low as 20 feet. 12 or 24 VDC output, up to 5 Amperes. Comes complete with manual and right nozzle for your site.

\$395. shipped free in Continental USA, CA residents add 6% state sale tax.

Dealer inquiries invited.

### Lil Otto Hydroworks!

Bob-O Schultze

POB 203, Hornbrook, CA 96044

916-475-3401

## Southwest Regional Energy Fair

### May 17-19, 1991 • Bernalillo, New Mexico

The Southwest Regional Energy Fair will be held in Bernalillo, NM, May 17-19, 1991, 10:00 AM to 6:00 PM each day. The fair will encompass all forms of energy indigenous to the southwest region. Workshops, seminars, open forums and historical and commercial exhibits will focus on energy conservation, building materials and equipment common to the Southwest. General admission is \$3 per day, \$5 for couples, and free to any kind of student.

#### Workshops:

1. Introduction to Solar Water & Space Heating- Dr. Roger Farrer, Public Service Co. of NM.
2. Passive Solar Water Heating- Bristol Stickney, Stickney Solar Consultants and Dave Fracassini, Zomeworks.
3. Active Liquid Solar Collector Systems- Hale Huber, Suntech Services.

4. Active Solar Collector Systems- Chuck Marken, AAA Solar Service & Supply.
5. Passive Solar Sunspaces- Bill Yanda, Brother Sun.
6. Swimming Pool Heating, Wayne Ullery, Sun Plus.
7. Solar Cooking- Tom Burns, Burns Milwaukee.
8. Under Floor Radiant Heating- Randy Sommer, DHW Supply.

Also Photovoltaic and other RE Workshops.

A limited number of booths (approx. 10X10 or 10X20) are available on a first come first serve basis. Booth start at \$140. For information on attending, becoming an exhibitor or a sponsor: S.R.E.F., SEMCO, 901 21st St. NW, Albuquerque, NM 87104 or call 505-247-4522.

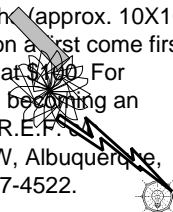

## SOLAR ELECTRICITY TODAY

The best resource guide & directory of suppliers, mail-order catalogs, books, and PV information.

Over 600 sources-\$7. From PV Network News • 11 years old this year!

**2303 Cedros Circle  
Santa Fe, NM 87505  
505-473-1067**



*The recipe for self-sufficiency?*

**POWERHOUSE PAUL'S STREAM ENGINES™**

**Just add water!**

Recharges 12 Volt batteries on heads from 5 to 50 feet.  
Works on flows from 3 gpm to 100 gpm.

Model DCT-1 (Direct Current Turgo- Model 1)  
**\$425. US • \$500. CAN.**

Prices include shipping, toolkit, five nozzle inserts and manual.

**Energy Systems & Design  
POB 1557, Sussex, N.B. Canada E0E 1P0  
506-433-3151**

# HAPPENINGS

## LMW&S/JEI Wind Workshop

Mick Sagrillo of Lake Michigan Wind & Sun, Forestville, Wisconsin in conjunction with Jordan Energy Institute of Grand Rapids, Michigan is offering a one week intensive, hands-on wind generator workshop from July 22 to 27, 1991. The workshop will include site analysis and system sizing; safety considerations; wind electric generators and alternators; rotor configurations and aerodynamics; tower designs; battery stand-alone and utility interconnect systems; and PV/wind hybrid systems. Installation and maintenance will be covered and in-field service work on an existing system will be performed. The cost of the six day workshop, including textbooks and printed matter, is \$280. Three hours of college credit is available for an additional fee. Registration is limited due to safety considerations. For registration information contact: Mick Sagrillo, Lake Michigan Wind & Sun, 3971 E Bluebird RD, Forestville, WI 54213.

## Hands-On Solar Workshops

The Solar Technology Institute is offering the following summer Photovoltaic and Solar Energy Workshops.

Photovoltaic Design and Installation, July 8-19, Carbondale, CO. Technical details of solar electric systems; practical engineering, hardware specification; & installations.

Solar Energy for the Developing World, August 5-9 in Willits, CA. PV and solar thermal systems for improving life in developing countries.

Solar Technology for Rural Health Care, August 26-30, in Carbondale, CO. This workshop focuses on the technical skills needed for using solar technologies in developing countries. Included are: vaccine refrigeration, lighting, communication, and water pumping.

The cost of a one and/or two week program is \$350. per week.

Solar Home Program 1991-1992. This series of How-To and Hands-On workshops is about designing and building state-of-the-art solar homes that are self-reliant, thermally efficient, healthy to live in, and environmentally conscious. PV Design and Installation, Sept.9-20; Advanced Photovoltaics for Remote Home, Sept. 23-Oct. 3; Micro-Hydro Power Systems, Oct. 7-10; Solar Home Design and Construction, Oct. 14-24; Energy Efficient and Solar Remodeling, Oct. 28-Nov. 21; Passive Solar Design for Professionals, Jan. 13-23; Heating the Energy Efficient Home, Jan. 27-Feb. 20; Solar Building Skills, Mar. 2-May 1.

For detailed schedules and descriptions, costs, and scholarship information write, Solar Technology Institute, POB 1115, Carbondale, CO 81623-1115 or call Ken or Johnny at 303-963-0715.

## Independent Power & Light Workshops

David Palumbo and Independent Power & Light of Hyde Park, VT will hold several intensive one-day workshops in the spring and summer of 1991. The workshops will include solar, micro-hydro and wind selection, battery choices - NICAD vs. lead acid, Charge controls, inverters, protection devices, wiring, and estimating loads for system design. Tours of state-of-the art systems will be made.

The workshop will be on April 20, May 25, June 20, and July 27, 1991. They will run from 8 A.M. to 5 P.M. Cost for each workshop is \$95, includes "The Solar Electric Home Book" by Paul J. Fowler, "The New Solar Electric Home" by Joel Davidson and a three ring binder full of product descriptions, reviews and catalogs. Lunch is included.

The books will be mailed on receipt of each registration. Please read the books prior to the workshop. A deposit of \$35. is required for registration as workshop size is limited. For more information contact: Independent Power & Light, David Palumbo or Kathleen DeCalle, RR1 Box 3054, Hyde Park, VT 05655, or call 802-888-7194.

## Backwoods Solar Summer Workshops

Backwoods Solar will be holding several one day workshops on photovoltaic equipment and installation. Each workshop is limited to ten people. The cost is \$40. per person, non-refundable pre-paid, which includes lunch and a text book (\$30 per person if 2 people share the text book). The workshops will be held on the first Saturday of each month, June 1, July 6, August 3, & September 7, 1991. For more information contact: Steve or Elizabeth Willey, Backwoods Solar Electric Systems, 8530-HP Rapid Lightning Creek Rd., Sandpoint, ID 83864, 208-263-4290

## Hands-On Workshops in Maine

The Maine Solar Energy Association has started a series of hand-on solar workshops all around the state of Maine. The purpose of these practical, one day events is to de-mystify solar energy. This is accomplished by showing the participants that it is practical today to use the sun to heat your home, make your hot water, furnish your electricity, and even cook your food and grow your vegetables out of season.

In the past year we have had a successful passive solar architecture workshop in Bangor, a solar greenhouse & sunspace workshop in Falmouth, and two photovoltaics workshops. The participants of the photovoltaic workshops actually constructed solar cell modules that they could take home for the cost of the parts. Some people made small solar battery chargers. Several participants assembled large 35 watt power modules.

In the coming year the expanded schedule of workshops will include; solar air heating, solar water heating, solar cookers and ovens, solar electric home, passive architecture, greenhouses and sun spaces, and the immensely popular photovoltaics workshop. The fee for each of these workshops is \$25., which includes lunch.

For information on sites and dates contact: Richard Komp, Maine Solar Energy Association, RFD Box 751, Addison, ME 04606, 207 • 497-2204

## Florida Solar Energy Center

Workshop Schedule for 1991 (subject to change). The Photovoltaic System Design Workshop will be held at the Florida Solar Energy Center on, June 4-6, & Oct. 22-24, 1991. This workshop will cover solar electric technology and the design of stand-alone and utility interactive PV systems aimed at engineers, government agencies, the solar industry and interested individuals. Cost \$150, in-state, \$300 out of state.

Energy Efficient FL Home Building: the newest ideas on designing & building an energy efficient home for home builders, inspectors & those thinking about building. 5/1 (Naples), 5/2 (St Petersburg), 5/21 (Pensacola), 5/22 (Panama City), 5/23 (Tallahassee) and 9/19 (Orlando) 1991. Cost \$45.

For more information contact JoAnn Stirling, 300 State Rd 401, Cape Canaveral, FL 32920-4099 • 407-783-0300

## NE Sustainable Energy Assoc.

May 21-25, 1991 - 3rd annual AMERICAN TOUR de SOL, The solar & electric vehicle championship, sponsored by NESEA, Albany, NY to Boston, MA. Contact: NESEA • 413-774-6051

May 24-26, 1991 - ENERGY AND ENVIRONMENTAL FAIR, Plymouth, MA. Contact: Earth Rising Productions • 617-489-4890

October 25 & 26, 1991 - SOLAR AND ELECTRIC VEHICLE SYMPOSIUM, Sheraton Hotel, Boxborough, MA JUST OFF RT 495. Contact: NESEA • 413-774-6051

## Sunnyside Solar Seminars and Workshops

"Photovoltaic Home Electric Systems - Seminar and Workshop" is a one day program given at Sunnyside Solar, Inc. in Brattleboro, VT. It provides an introduction to independent solar electric systems and includes a hands-on workshop assembling a four module system. Each program is complete. The 1991 schedule is may 18, June 29, July 27, September 28 and October 19, each on a Saturday, 9 am to 4 pm. Advance registration, with a \$35

deposit for each person, is required. The balance of \$95. per person is due on the day of the workshop. Registration for each session is limited to the first eight deposits received. Included in the day's program is lunch, a packet of product information and related articles, and Joel Davidson's "The New Solar Electric Home".

For additional information and registration, contact Carol Levin, Sunnyside Solar, Inc., RDF4 Box 808, Green River Rd, Brattleboro, VT 05301, 802-257-1482

## Minnesota Energy Council

The MN Energy Council will hold a number of conferences on new technology in energy and environmental management for housing, small buildings, small business and municipal buildings, aimed at professionals and business people. For more information contact: Roger Peterson, Minnesota Energy Council, Box 8222, St. Paul, MN 55108 • 612-378-2973

## Solar World Congress

The Solar World Congress of the International Solar Energy Society will be held on August 17-24, 1991 in Denver, CO. Contact: American Solar Energy Society, 2400 Central Ave. Ste. B-1, Boulder, CO 80301 USA, 303-443-3130, FAX 303-443-3212.

## SunAmp Seminar

SunAmp Power Co. will hold two, 2 day PV seminars on May 17 & 18, 1991. The seminars are designed for everyone from professionals to do-it-yourselfers. Topics will include introduction to PV hardware, demonstrations of systems, instrumentation, information access, system design and marketing. Cost of each seminar is \$145. (\$100. for each additional person in the same party) and includes two lunches, refreshments, syllabus & classroom materials. For more information contact Steve at SunAmp Power Co., POB 6346, Scottsdale, AZ 85261-6346 • 602-951-0699 or TOLL FREE 1-800-677-6527.

## The "Nellie E" Solar Saloon Party

Anyone near Parker, AZ on April 27-28 1991 should consider stopping in the "Nellie

E" Solar Saloon for their "Desert Storm Solar Party". The saloon is run strictly on solar power. If I hadn't seen the newspaper article on the Solar Saloon I'm not sure I'd have believed it myself.

Like Home Power Central you can't find the Solar Saloon without directions. The following directions are from the newspaper article I have. "The Solar Saloon is located on a mining road, five miles upriver from Parker, AZ in the foothills of the Buckskin Mountains. The road exits easterly from the new section of Arizona 95, one mile north of the traffic light at Jug's Sandbar. On the dirt road, turn right at the first fork, then left at the second fork in the wide wash. For the next three miles you should have no problem if you follow the most traveled road. At about mile 4 from the pavement there are concrete pads on both sides of the road. Do not take the right fork which deadends. When you climb through two metal gate posts at a gap, you are within a sharp whistle of the saloon. Take either of the roads at the bottom of the short hill; both lead you to the Nellie E Solar Saloon. It's a little over five miles from the pavement and worth every bump to see the saloon in wait of a town."

## Solar Potluck- Tucson, AZ

Citizens for Solar is hosting it's 9th solar event on May 4, 1991 from 9AM to sundown at Catalina State Park. There will be 75-100 solar ovens in use. Anyone who cooks solar or brings a prepared potluck dish is welcome to chow down with the solar chefs. Exhibits and demonstrations on solar ovens, solar water heaters, PVs, solar electric cars, solar distillation, RVs utilizing solar energy to power auxiliary and more. For more information contact: Citizens for Solar, POB 40372, Tucson, AZ 85717 • 602-325-7860.

## Energy Independence- Eugene, OR

Join the folks in Eugene, OR for Energy Independence Day, June 1, 1991. The event is being held at the Outdoor Fair on the corner of 8th & Oak, Eugene, OR. See renewable energy in action. For more information contact: Kathy Ging, POB 11245, Eugene, OR 97440 • 503-342-8461.







# Good Books

## Alternative Energy Sourcebook 1991

Published by Real Goods Trading Company

This year's Real Goods Sourcebook is a bonanza of information and products.

Within the sourcebook's 400 pages, I found realistic and useful information about renewable energy and efficient power use. Articles make up over half this book, and the rest is product advertising. This format is very effective. It provides the information required to make energy related decisions, and then gives access to the actual products.

The list of contributors reads like a Who's Who of renewable energy. Amory Lovin's foreword is alone worth the price of admission. The articles are specific and deal with the hands-on use of renewable energy and practical energy conservation. What amazes me is the diversity of topics and products covered in this sourcebook. Here's a list of the major items:

1. Systems Planning- An Overview
2. Power Generating Devices & Whole Systems
3. Power Storage and Management
4. Alternative Power Loads
5. Conservation and Purification
6. Tools and Appliances
7. Education and Consumer Products
8. Electric Vehicles
9. Appendix -NEC part 690 & Glossary

### Of particular informational note:

This sourcebook is filled with need-to-know stuff. Included are a copy of Part 690 of the NEC dealing with low voltage systems, and a thorough coverage of efficient lighting & refrigeration. Articles on system design are accurate and read simply for the absolute novice. Water pumping is covered, as are more esoteric RE applications like water purification, and heating.

### The Products

While the 1991 Alternative Energy Sourcebook contains lots of information, it is also a mail-order catalog that will sell you the devices you read about. I found a very large

selection of efficient and appropriate products. Everything from PV panels to water heaters to books. The products are fairly and accurately described. Let's face it, no product is absolutely perfect. The Real Goods staff have reviewed each product, and are honest about any warts. Virtually every product that may find use in a home power system, or in an efficient grid connected system, is in this catalog.

### Conclusions

Real Goods' 1991 Sourcebook belongs on every RE bookshelf. If you are just beginning, you will appreciate the informative articles. If you're already making your own power, then you'll like the specific product information. The environment appreciates that the sourcebook is printed on recycled paper!

### Access

Reviewer- Richard Perez, C/O Home Power, POB 130, Hornbrook, CA 96044 • 916-475-3179.

Sourcebook: Real Goods Trading Company, 966 Mazzoni Street, Ukiah, CA 95482 • 800-762-7325. The 1991 Sourcebook has a cover price of \$14, but Home Power readers can get it for \$10 (which is refunded on your first \$100 order).



## Alternative Transportation News (ATN)

Published by Earthmind, Michael Hackleman, Editor

It's out!

Michael Hackleman's new magazine about transportation has become a reality with this March's issue. Alternative transportation has long needed its own magazine. Covered in this issue of ATN is everything from electric vehicles to airships to bicycles. If it moves and doesn't guzzle gas, then it's in here.

Specific topics in ATN's premier issue are: EV racing, Alcohol Fuels, Reports on commercially made EVs, Airships, Batteries, Bicycling, and Human Powered Flight. Also included is advertising from the folks whose products make it really happen.

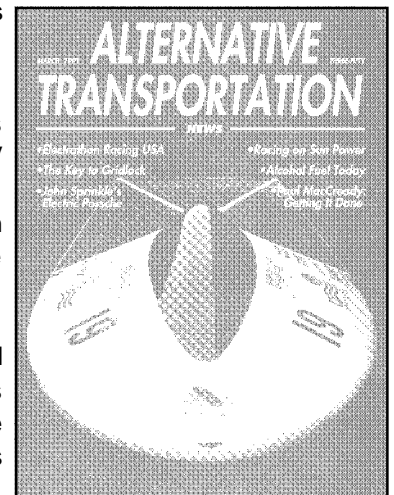

## Good Books

I especially liked the article by Michael Hackleman on lighter-than-air craft. It is well written and full of technical data regarding airships. I also liked the article about the conversion of a Porsche to electric power. And the article about Clyde Beasley's Slingshot electric racer. This magazine is full of swell info about getting down the road without killing our planet.

ATN is bi-monthly and is in a black & white, 8.5" by 11" format. The premier issue is 36 pages including cover.

I salute Michael Hackleman and the folks at Earthmind for putting together a much needed publication. They've got my attention and I recommend their work to you.

### Access

Reviewer- Richard Perez, C/O Home Power, POB 130, Hornbrook, CA 96044 • 916-475-3179.

Alternative Transportation News: Earthmind, POB 743, Mariposa, CA 95338 • 213-396-1527. Cover price of ATN is \$3.50 and a one year's subscription costs \$12.



### PURE CASTILE & VEGETARIAN SOAPS

Handmade in an AE environment of the finest ingredients, we have soaps, cremes, bath salts and more. Send for our **FREE** catalog:

### **SIMMONS HANDCRAFTS**

42295AE, Hwy 36, Bridgeville, CA 95526

## ENERGY SPECIALISTS

Siemens Solar Industries, Kyocera, Zomeworks, Trace, Statpower, SCI, Heliotrope, Bobier, Flowlight, Solarjack, Harris Hydroelectric are only a few of the available items in stock. For your energy needs whether it is designing a system or expanding your existing power call or write today, we will provide you with a free catalogue. Sure as the sun shines you can save a few dollars on any real price quote.

### •CURRENT SPECIALS•

12, 24 volt DC or 120 ac highly efficient 16 cu ft refrigerator/freezer \$1895.00, \$50.00 crating fee also covers shipping anywhere in California, "slightly" higher for out of state.

SDS Submersible pump \$725.00.

Kyocera 51 Watt PV modules \$349.00 ea. + shipping

ARCO 110 watt Tri-Lams \$459.00 + shipping

### ENERGY SPECIALISTS

P.O. Box 188710

Sacramento, CA 95818

916-392-7526

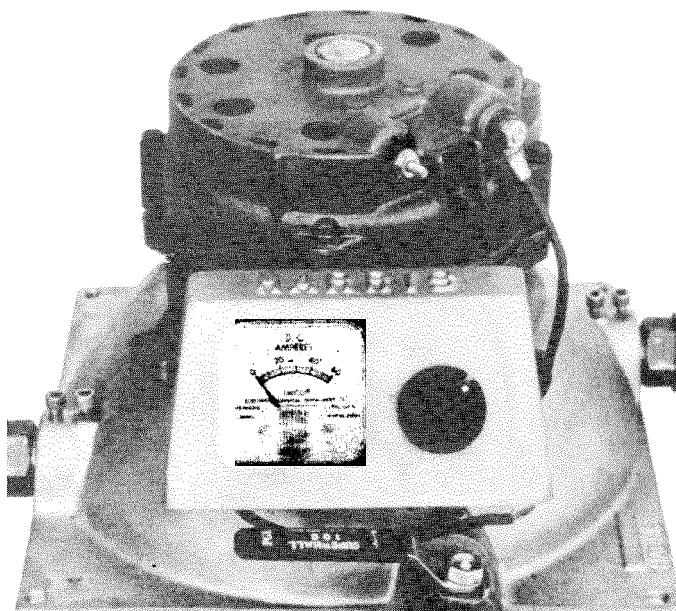
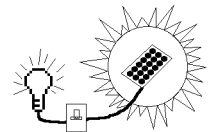

## HARRIS HYDROELECTRIC

### Hydro-Power for Home Use

632 Swanton Road  
Davenport, CA 95017

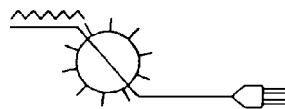

408-425-7652

Works with Heads  
as low as

10'

Prices start  
as low as \$595.

**Prices must go up July 1**

*"The best Alternator-based MicroHydro generator I've ever seen."*

*Bob-O Schultze*

*Hydroelectric Editor, Home Power Magazine*



## the Wizard Speaks...

### For Mathematicians Only

Here's a little idea I have in the realm of transfinite mathematics. It is said that the smallest transfinite cardinality is aleph-null, the cardinality of the set of integers. It is my belief that a smaller transfinite cardinality exists, that being the cardinality of the set of prime numbers. It appears to me that the power set of the set of primes is imbedded in the set of integers. (The power set of a set A is equal to the set of all subsets of A.) If this supposition is true the cardinality of the set of primes is less than the cardinality of the set of integers. Neglecting the numbers zero and one, the elements of the power set of the set of primes can be shown to have a one to one correspondence with a subset of the set of integers. This can be done in the following manner. If the product of all the elements of a member of the power set of the set of primes is taken, this product corresponds to an integer. In this way, all members of this power set correspond to a different integer. Not all integers are represented. Thus, the power set of the set of primes is embedded in the set of integers and aleph-prime (the cardinality of the set of primes) is less than aleph-null. This follows from Cantor's Theorem which states that the power set of any set has a cardinality greater than the original set. Please send your comments to me c/o Home Power Magazine.



# ATN

ALTERNATIVE TRANSPORTATION NEWS  
SOLUTIONS • EDUCATION • NETWORKING • FOCUS

Everything from electric vehicles to bicycles.

Six issues per year for \$12

EARTHMIND

P.O. Box 743, Mariposa, CA 95338

## Writing for Home Power Magazine

We specialize in hands-on, practical information about small-scale renewable energy production and use. We publish technical material in an easy to understand and use format.

### Informational Content

Please include all the details! Be specific! Write from your direct experience- Home Power is hands-on! Please include full access data for equipment mentioned.

### Article Style and Length

Home Power articles can be between 500 and 10,000 words. Length depends what you have to say. Say it in as few words as possible. Use simple declarative sentences- short and to the point. Use Sub-Headings to organize the information. Check out articles printed in HP to get the feeling of our style. Please send a double spaced, typewritten copy if possible. If not, please print.

### Editing

We reserve the right to edit all articles for accuracy, length, and basic English. We get over three times more articles submitted than we can print. The most useful, specific and organized get printed first.

### Photographs

We can work from a color or black & white photographic print. If your photo is for the color cover, then send a color transparency (color slide).

### Line Art

We can work from your camera-ready art. We can also scan or redraw it. We can generate tables, charts, and graphs from your data.

### Got a Computer?

Send your article on disk if possible. We use Mac computers. Please format all word processor files in ASCII "TEXT" format. We can read text files on 3.5" IBM disks. Format all graphics as PICT. Use 10 point Helvetica for all text embedded within graphics.

### Want your material returned?

Please include a stamped, self-addressed, return envelope. Otherwise your material will not be returned.

### Copyrighting

If you request it, we will copyright your work in your name. Otherwise we will copyright the information in Home Power's name.

### Got any questions?

Give me a call at 916-475-3179. This saves everyone's time. *Richard Perez*



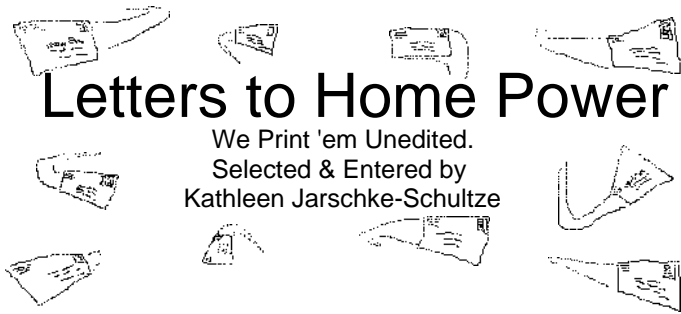

## Letters to Home Power

We Print 'em Unedited.  
Selected & Entered by  
Kathleen Jarschke-Schultze

### Renewable Neophyte

This is an amazing magazine! First issue I've seen is #20 (and yes, the color cover was what caught my eye) at my local Whole Foods Market. I never dreamed that the state of alternative power had reached this point. My mind is afire with ideas.

Of course, as an apartment dweller, going alternative is kinda difficult. When we relocate we will explore our options more fully. The first project I see is converting our hydroponic vegetable garden (now under construction) to PV power. First for the nutrient aerators and heaters, and eventually including the fluorescent lighting system. I'll tell you more when I get this off the ground.

Can't wait for the next issue. Til then, keep the faith!

P.S. How do I find out what is in the available back issues? Do you have some index?

Kevin L Corridon, Houston, TX

*Thank you, Kevin, it's good to hear that the color cover is working. In HP issues #11 and #18 there are indices to previous issues. Every year we publish an index to that year's issues to keep the information accessible. Next one is coming up in HP#23. KJS*

*You don't have to move to the country to get started, Kevin. Now's the time! See the article about efficient electric power use on page 11 of this issue for example. Grid connected folks can save bucks and the environment by applying efficient lighting, refrigeration, and other energy savers. All this high efficiency equipment can move with you to the country, and give you a great head start on your home power system. RP*

### Perchance to Dream

Dear Home Power, First off, I would like to thank you from the bottom of my heart for all you've done. The world is becoming a much better place thanks to your efforts. I've received every issue since HP#1 and look forward to receiving a lifetime more of them. Don't sell out on us like "The Mother Earth News" did (now they call it "The Original Country Magazine").

Presently I am First Officer aboard the hospital ship "USN MERCY" in the Persian Gulf. What a mess we're in. I hope this can end peacefully and we can all get home alive. I wish that I could get a floppy disk to send this to you on.

To help maintain sanity, I sometimes daydream about my future and the things I love; soaring, the outdoors and my partially completed AE powered home in the Tehachapi mountains of California. Your magazine is refreshingly peaceful in this hostile and trying time.

My most recent idea is about converting a conventional gasoline vehicle to electricity. I have bought many of the books available on the subject, but have some ideas of my own.

I want to start with a early 1980s Volkswagen Rabbit pickup truck. They are available with worn out engines at a reasonable cost. This vehicle is sturdy, lightweight and has a large cargo bed for storing a battery pack, solar panels or perhaps a gasoline powered battery charger. My theory is that you can use two battery packs so that one may be removed and be recharging (using wind or solar) while the other is in use. If a long trip is necessary, both battery packs may be used in the bed of the truck at the same time, or carry a gasoline powered onboard recharger running continuously to increase range. The pickup bed arrangement allows maximum flexibility for loading/unloading battery packs and equipment.

I would be interested to hear or see if anyone else has experimented with this VW Rabbit pickup concept.

I have many theories on Life. One is that aviation works like a self cleaning oven. Another is, chance favors the prepared mind.

Sincerely, William S. Brewer, Fresno, CA

*William, get in touch with Michael Hackleman at Alternative Transportation News (ATN), POB 743, Mariposa, CA 90291 or call him at 213-396-1527. ATN specializes in electric vehicle information and access. The Rabbit pickup should be a viable platform for an EV. RP*

### Electric Vehicle

Dear Karen, This is the electric car I was telling you about, by phone, a month or two ago. As I said at that time the range is only about 40 miles (with all the hills we have), but the speed is over 70 MPH (we do not go over 60 or so). We are using 20 Exide GC-4 batteries in series for 120v DC. We will try to write more in detail and include some good black and white photos for your



Above & Below: Debby Henne's electric car.



magazine. Hope you had a nice Holiday and hope your New Year is good and prosperous.

Sincerely, Debby Henne, Robesonia, PA

**Change for the Better**

Dear Home Power Crew, Have been wanting to write for a while now, and here's my opportunity.

Really like and appreciate your magazine. Much useful and inspiring information and access to products. Some of the technical stuff gets beyond my capability, but then I just get other information from books, etc., to help fill in the gaps. Recently took an evening class in electronics to better understand how my system works.

Especially like the nuts and bolts stuff - converted a standard small (7 cu ft) freezer by adding insulation, etc. as your article showed. Would also like to make a solar

cooker and try using it to cook. Would like to ask Kathleen Jarschke-Schultze, how can this idea be adapted to a solar food-herb dryer?

Also like the Things That Work! articles. AE answer to consumer reports.

Use a lot of batteries around the house and recharge them from my PV supply. There are TOO MANY of those AC appliances that are really DC and "recharge" via a power wasting phantom load "cube" or internal transformer. Also use line cord switches for appliances for the same reason. I was amazed when I first hooked everything into the inverter and heard everything humming!

Would like to see an article on outdoor lighting that is either AC or DC and self regulating (timer controlled) or motion sensing that is cheap, easy, DIY potential high and of course energy efficient! Lots of equipment out there - Real Goods, and others. Much is expensive, and what works best with what? DC timers are expensive; so AC means needing an inverter - how much phantom loss? Could use motion sensors - but fluorescent flood bulbs (AC cheaper here, too) going on and off is not good for the bulbs. Get the dilemma? I am from the city, originally, and think outdoor lighting is important to crime deterrence; in town or out in the boonies.

I live in a conventional house with added energy efficiency \_ insulation, low-E windows, high efficiency natural gas furnace, (I know wood is renewable, but the air pollution and fire potential are major drawbacks to its use). Instead I had a solar supplemental heater (T.A.P.) added to the house. This was to decrease my gas bills - They got higher as the years went by. So, what to do to get my increasing electric bills under control? PV to the rescue!

If not for tax credits allowed for renewable energy equipment, I might not have gotten into a PV system because of the initial cost. But now, I'd like to be off the grid in the future by using a natural gas generator in winter when sun is scarce. I have a 30 amp system gel-type low maintenance 12v batteries, Heart 1200 inverter with charger, Sunfrost 12v fridge, and mostly fluorescent lighting.

Keep up the good work, Pat Lambert, York, NY 14592

*Well, your letter got my attention, Pat. I'm experimenting in solar food/herb drying right now. I'll write it up soon.*

KJS

*Hi, Pat. In general, more folks are going to 120 vac use*

*via the inverter. The reasons for this are those you have mentioned (primarily, the appliances are less expensive and more available), and because of recent advances in inverters. See the article on the PowerStar UPG inverter on page 22 of this issue. Inverters are now more efficient and reliable. With an inverter that is efficient at low output power, all manner of 120vac devices that were phantom loads suddenly become faithful servants. In any case, 120 vac security or outside lighting is much easier to install. The large wire needed for long low voltage runs is expensive, and often costs more than the lights themselves.*

*It is less cost effective to use fluorescent lights where they are turned off and on many times daily. The finite life offered by the fluorescents starter is the limiting factor. Incandescents are the best bet for frequently activated lights that spend less than one hour per day operating.*  
RP

### **Ecuador Environment**

Dear Home Power Readers, During a December visit to Ecuador I became aware of some grass roots projects of great environmental and social importance. Doug Ferguson, an Australian, working with the Ecuadoran government asked me about alternative energy possibilities for a long house being built this year for indigenous groups in the Andes. This will be a public meeting space to educate people on resource management, legal rights and perma-culture. Perma-culture would put an end to the slash and burn or yearly burns of fields that so depletes the soil and fouls the air. Solar-cooking information is another premier project they are working on.

I have promised to look into donations, funding or cheap sources of solar and/or hydro equipment. Apparently there is a permanent stream at the long house site for hydro and I have asked for more specifics, but as I am currently in Mexico I have not received a reply yet. All that will be needed initially is some lighting for meetings at night, so they are not talking about much money. These people are at the forefront to a solution to the great social-ecological dilemmas of Latin America. I regret that this letter is so vague, but am trying to initiate things since they hope to install by fall of 1991. If anyone has ideas on funding or resources for equipment or how to approach dealers or wishes to participate in installation please correspond with me at: David Evans. POB 531. Moab. UT 84532

*David, we salute you. KJS & RP*

### **Human Powered Discount**

Dear Home Power Folks, Thanks to Karen for the HPs' to pass around. They went like hot cakes. Interest in renewables is on the rise in our neighborhood. Thanks to Bob-O (& whoever helped) for prompt and safe shipment of our order. On the day bombs flew to Bagdad we disconnected the boat shop from the power grid and hooked up four K-51s and a Trace inverter. This is our demo unit for potential customers of Arcana Solar Sales.

Also, with the onset of fighting in the oil war, we changed the price structure of our roadside oyster market. Customers using human-powered transportation receive a discount of 1/2 off. Transit riders and renewable energy vehicles get 1/3 off. We've had one pedestrian so far who qualified for a discount, and lots of interesting conversations with car drivers. Folk showing interest in the car-oil-war connection are given the enclosed flyer.

One of our best "energy saving appliances" is our homemade passive solar human waste composter. We live in a 24 ft lifeboat (in the background with 2 Kyoceras on a Track Rack) so there is no room for a toilet like a Sun Mar. We use a common marine or RV type porta-potti with reservoir (5 gal), emptying about once a week for 2 people. The composter requires emptying once a year. The 4" vent is 10' tall, carrying about 2/3 of the water vapor out. The rest of the water condenses on the underside of the flat FRP glazing, dripping into a gutter on the lower edge to run off into planters (tire tubs) for irrigating. Grass and straw from the surrounding area is layered on top of each dumping, eliminating odors and insect problems. A 2" foamboard insulates the bottom of the simple box, which is 4'x8'x11" deep. The box is divided into 4'x4' sections for dumping alternately, allowing better dehydrating between loads. I should add that moisture is collected separately, treated with lime and rock phosphate powder to make superphosphate, and fed to the garden (aged 2 weeks and diluted). Willapa Bay (and our one-acre oyster farm) are in the background. The abandoned oyster scow, on which the composter sits, no longer floats, but the composter itself has floated on occasion, when extremely high winter tides flooded the surrounding field. Likewise, our life boat only floats on very high tides, normally resting securely on a pair of bilge keels. We live in the intertidal zone. P.S. Please include us in Ozonal Notes mailing list. Thanks. Keep up the good work.

Pacifically, Larry and Marge Warnberg-Welling, Nahcotta, WA



Above: Marge wading through high tide. The octagonal hunt (floating on five gallon buckets) is used to sell oysters at local festivals.

All of these turntables used magnetic cartridges, which require a pre-amp. (i.e. you need a 'phono' input on the back of your amp, 'Aux' will not do.) In the past Hitachi and JVC made high end component portables with built in preamps. They no longer make them but they may be available used. Look for Hitachi J-3 or JVC PC-11 JW or JVC PC55. At the time list prices of these were high (\$350 to \$500). Sharp made a 'boom box' model GF8585 which had a preamp built in. It was cheaper (\$250) but less versatile and of lower sound quality.

12 volt component preamps, which would allow virtually any portable stereo to utilize a magnetic cartridge turntable through its 'Aux' or 'CD' input, seem to be rare. The only one I'm aware of that is available is an inexpensive TSM kit #34 for \$9.19 + shipping from Prospect Electronics, POB 9144, Allentown, PA 18106 (215)

770-9029. Hope that helps. Bear from Bodega, CA.

*Sounds great to me. Thank you for your participation in educating people to renewables and living THE lifestyle. If you weren't so far away you could bet Bob-O and I would hike on by for few of those oysters. KJS.*

*Thanks, Bear, you are a veritable fountain of useful information. I get the idea that if we don't know the answers, one (or more) of our readers will. KJS*

*Pleased to meet you, Larry and Marge. I'll put you on the OOZIE mailing list. Although I've been working on the OOZIE Backwoods EV steadily, the info is still not ready to print. So, it'll be awhile. RP*

#### **Of Steam and Shavers**

#### **Tables Turned**

Dear HP, In response to the HP letter from Chip Usal, Mt. View, UT in the Dec/Jan 1991 issue, I'd like to let him know that Tecnic's made three models of turntables that were factory wired to run on 12 volts. Models SL-7, SL-10, and SL-15 were all high quality linear tracking turntables that had 12 volt input jacks. All three had stroboscope, pop up 45 adapter, quartz lock direct drive motor, and automatic start, stop, return, repeat, disc size sensing, and speed setting. In addition the SL-15 was programmable and the SL-10 included a preamp for moving the coil CARTRIDGE, which it used. Unfortunately these are no longer made. I got my SL-7 for \$100.00 thru the local want ads.

Dear People, First; I REALLY was surprised and delighted by your 100 pg. issue! 'Nuf said!

Comments: Issue 21, pgs 55 & 56, on fire tube boilers. I know it's talking about solid fuel fed systems, But! Stanley Steamer was a fire tube boiler and the safest also because each tube was itself a safety device. If one tube failed that was all that would happen as the outer shell (which was wrapped in piano wire) and both ends were extremely above the capacity of any of the fire tubes. Incidentally, flash boilers were and are the most dangerous. And these are much like the 'on demand' propane water heaters! 'Nuf.

Locally, one of the stereo stores used to (don't know if they still do) convert turntables for 12v use. The Yamaha P-200 is a model they converted for use by a friend of mine. The store was Golden Ear in Santa Rosa, CA.

Question: On solar panels; is it possible to produce solar panels that work at Infrared frequency? If so, they could be used indoors all the time the wood stoves are going! Walls and ceilings, even the heat shields behind? I don't know anything about the light freqs and solar cells, but what about this void?

Item that does NOT work on an inverter. Norelco electronic shaver (model unknown) does not work on

Power Star 200, but does work fine on 120 VAC generator. Power Star does work fine, but not for the shaver. I expect there to be a problem between the modified sine wave and the electronic control.

Also a cordless Norelco had a percentage meter (0-100%) of Nicad battery charge. I thought I had read somewhere in back issue of HP that the percentage of charge of a Nicad was difficult to determine. If so, then has Norelco figured out something?

Question on refrigeration: I have not seen any references to a RV refrigerator gas/12VDC/120VAC. What efficiency of the electric mode if used on 12VDC or small inverter on 120VAC? Would adding more insulation around increase efficiency? Anybody out there know?

Question on Nicad batteries: Back in HP#4 an article on flashlight sized batteries A,C, and D. I have a Radio Shack Cat. that lists Amp. Hour ratings of their Reg. and Hi Cap. batteries - I have never found anybody else lists theirs - but Radio Shack batteries are well below the amp hour ratings you listed in the article. Just exactly were those you have listed? Not Panasonic or GE or anything I've seen in stores. Does Pacific West Supply carry them? Or who? You also mention 'Ripoffs' of C size in D casing. Is that the regular size D listed in Radio Shack at 1.4 Amp Hour? Etc., etc., maybe can clarify for a lot of HP readers! 'Nuf for now, Bye, Richard Cameron, Dillard, OK

*Hi, Richard. To the best of my knowledge there are no realistic thermovoltaic devices. PVs make power from visible (and near ultraviolet) light because their PV junction is tuned to those particular frequencies. Thermovoltaics are semiconductor junctions tuned to lower frequency radiation like heat. While we heard of several types, none are available for consumer use. The problems yet to be solved in thermovoltaics are : short lifetime, overheat damage, and low power output.*

*Your shaver is probably using a triac or SCR for motor speed control. Anything using these sinusoidal only ac power control semiconductors will not run on mod-sine wave inverters. The battery charge meter on your shaver is strictly ball park. If it says zero, then you're flat. If it says 100%, then you're at anywhere from 60% to full. All other readings are suspect. It is very difficult to determine nicad state of charge by voltage measurement. In general, a sintered plate nicad (flashlight cell) has a voltage of about 1.30 VDC when full charged and at rest. A totally depleted cell will show over 1.1 VDC at rest. Bottom line with sintered nicads is RUN THEM FLAT! Sintered plate cells have a memory and need to be totally*

*cycled, so fully empty them before refilling.*

*On small nicads. While Radio Shack sells many fine things, their nicads aren't one of them. I recommend the Panasonic nicads available from Digi-Key (800-344-4539). They ain't cheap, but I've beat up all kinds for years now and these Panasonics come out on top. My favorite AA is the Panasonic P-50AAR (recharges in one hour, capacity 500mA-h) for \$2.65 each. Digi-Key also sells the 4 Amp-hour Panasonic P-400D for \$11.03 each. The Radio Shack D sized cell rated at 1.4 Amp-hours is indeed a C cell in a D cell case. Radio Shack sells what they term a high capacity D cell rated at 4 Ampere-hours (part #23-140 for \$7.95). I find the Panasonic cells to be of much higher quality, which translates into more cycles. RP*

### **Reject or Rebate**

To Whom It May Concern: I began in October, 1990 to get a mortgage on my home. I live in a rural area, thirteen miles outside of Santa Fe, N.M. city limits, and have no conventional utilities. I was fortunate to install a solar electric system before Ronald Reagan stopped the solar rebates that Jimmy Carter initiated. With the energy state of the world today, I would expect to be cheered for having alternative energy, instead I have been punished.

I have been turned down eleven times and told it is impossible to get a loan from both banks, and private investors. I have tried to get loans in New Mexico, Arizona, California, and Colorado. Still I am rejected. I would not mind if there were other reasons but the only one stated was solar electric. It is difficult to believe that solar energy is so unacceptable a risk.

How can our nation be so blind and backwards considering our energy crisis? How can we, in all conscience be spending billions of dollars on a war fighting for oil without exploring and experimenting with alternative energies? Have we all gone mad? Do you know that not only is solar electric efficient, but is ecologically sound emitting almost no fumes into the air.

Now, as a single woman, I am further penalized by our governmental income tax. Since I cannot get a mortgage I have no deductions and am forced to pay a high premium for defense weapons.

I am outraged! I am a fifty three year old woman, having worked for thirty two years, supporting my government, living with integrity and being an ecologically and humanely aware person.

Where are our priorities? Do we want to save the earth or don't we care? We must turn things around and become a conscience people NOW. Speak out for the earth! Your action to increase energy awareness would be greatly appreciated. Carole Silon, Santa Fe, NM



*Well, Carol, you are not alone in having difficulty finding financing for renewable energy systems. Banks are very conservative and using renewable in a home is radical cutting-edge stuff. Take heart, you are doing the best thing you can do— living on your own power. Your efforts stand as an example and are far more effective than thousands of letter to congress persons. Eventually the financial and political establishment will catch on, and it's the work of folks like you that will make it happen. RP*

**Horse Power**

After seeing the picture of Karen's mare Oozie in issue #21, I was reminded of a subject that has not been mentioned in Home Power. Namely Horse Power - real honest to goodness HORSE POWER.

I would love to have a couple of draft horses and harness and maybe a wagon. Unfortunately the price of all that makes it just a dream. Besides, feeding those giants would run into some bucks.

But if your family is like ours and must always have a horse or two anyway, go ahead and put them to work. They would probably appreciate the extra attention and benefit from the added activity.

First I must say that a light horse cannot be expected to go out and pull a plow or skid heavy loads. It could injure itself and maybe have an accident. Or perhaps become balky and uncooperative at the least.

Our horses, Nipper at twenty-eight years old and Fanny Ann (the kid) at eight, have hauled supplies up to our place when the snow was too deep for our four wheel drive trucks.

All you need is a willing horse, a heavy duty western saddle, a breast collar and a rope. We also acquired an old automotive hood found by the side of the road.

You just tie your supplies onto the underside of the hood. Then attach one end of your rope to this hood and the other end to the saddle horn. Use a quick release knot or just wrap it around a couple of times and hold it just in case of an unexpected occurrence. Get on your horse and off you go. The hood slides over the snow like a sled and it carries a lot.

Our horses have carried feed in, tied on their backs, when it was too muddy to get a truck in. They have hauled oak branches to be sawn up for firewood. As an added bonus, they make a constant supply of organic fertilizer for the neighborhood gardens.

All this and more from a good friend and companion.  
Patricia Walker, Big Bend, CA



Above: Rick Walker and his mare Fanny Ann, hauling in hay.

*Hi, Patricia & Rick. This story sounds familiar. Our Oozie has packed in groceries, firewood, and provided us with compost for years now. KP*

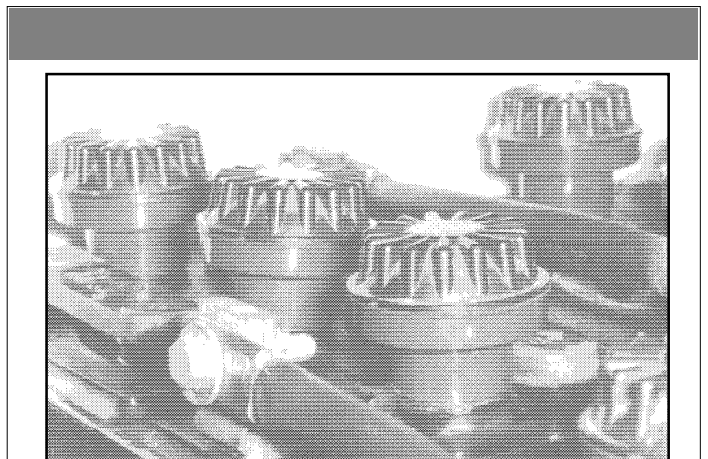

**WE MAKE WATER FROM YOUR GAS**

Hydrogen and oxygen battery gas catalytically recombined into pure water and returned to each battery cell. Keeps battery topped off for extended periods of time and reduces maintenance costs. Explosive hydrogen gas is virtually eliminated from the battery area. Corrosive spray and fumes are contained and washed back into each battery cell. Electrolyte kept strong longer, extending the useful power and life of the battery. HYDROCAP Vents simply replace the battery's caps. Battery maintenance is greatly reduced. Write or call for more information.



305-696-2504  
975 NW 95 St.  
Miami, FL 33150

Support HP Advertisers!

## Solar Energy Workshops

**July – August 1991**

### Summer Solar Technology Workshops

Photovoltaic Design and Installation – Colorado  
Solar Energy for the Developing World – California  
Solar Technology for Rural Health Care – Colorado

**September 1991 – May 1992**

### Solar Home Program Workshops

Photovoltaic Design and Installation – Colorado  
Advanced Photovoltaics for Remote Homes – Colorado  
Solar Home Design and Construction – Colorado  
Energy Efficiency and Solar Remodeling – Colorado  
Passive Solar Design for Professionals – Colorado  
Heating the Energy Efficient Home – Colorado  
Solar Building Skills – Colorado

Solar Technology Institute  
P.O. Box 1115  
Carbondale, Colorado 81623  
(303) 963-0715

**Solar  
Technology  
Institute**

## Tour de Sol Earth Fair

Products, Services and Technologies for a  
Healthy Environment

New England's cutting edge event  
promoting Alternative Energy

Technologies and Environmentally Friendly  
Products and Services for the Home, Office and  
Community

**May 25th & 26th**

**Cordage Park, Plymouth MA**

Educational Exhibits and Displays, 50+ Solar &  
EVs, Workshops, Demonstrations & Entertainment  
A Benefit for the American Tour de Sol; Solar and  
Electric Championship

*For more information contact:*

Earth Rising Productions, Inc.  
P.O. Box 1078, Boston, MA 02272  
617-489-4890

# SEER '91

## SOLAR ENERGY EXPO & RALLY

August 9, 10, & 11, 1991  
Willits, California

ELECTRIC VEHICLE RACES  
DEMONSTRATIONS • EXHIBITIONS

***THE West Coast Energy Fair!***

See Page 76 of this issue.

**SEER '91**  
239 South Main Street  
Willits, CA 95490  
telephone: 707-459-1256

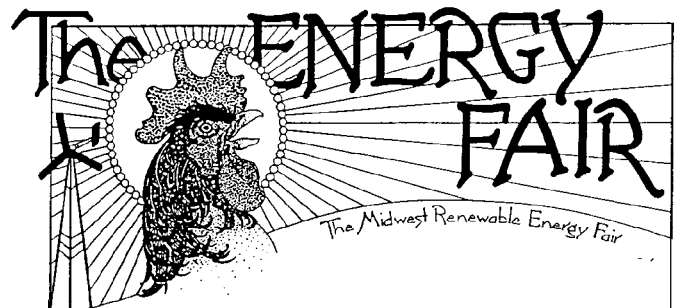

## MIDWEST RENEWABLE ENERGY ASSOCIATION MEMBERSHIP DRIVE 1991

JOIN THE MREA!

- \*Free 1991 Energy Fair T-Shirt
- \*Free Admission to the 1991 Energy Fair
- \*Quarterly Association Newsletter
- \*Reduced Rate Classified Ads in Newsletter
- Annual Basic Membership Rate \$25/person
- \*GIFT MEMBERSHIPS AVAILABLE\***

To purchase your membership or for more detailed  
information write or call:

116 CROSS STREET, P.O. BOX 249  
AMHERST, WI 54406 • (715) 824-5166

# Q&A

## Curie-ous

Dear Home Power Folks, Thanks for a well done and informative publication. Do you folks have any information about there being a small amount of radioactive material used in certain compact fluorescent lights. In particular the Panasonic Light Capsules uses a substance called Prometheum to aid in starting the lamp. Prometheum puts out a certain amount of curies of radioactivity. Does this create any sort of health hazard? Do any other of the compact fluorescents contain this element? If any readers have any info, please pass it along. Keep on spreading the word about renewables. Regards, Larry Brown, Olivebridge, NY

*You are correct in stating that this light uses a small amount of radioactive material in its starter. In order for this amount of radiation to be a hazard you would have to break open the light and eat the contents. Not very likely or appetizing. If you want no radiation in your lights, then consider the Osram EL types which use a switching ballast. RP*

## Fluor-efficiency

Dear Home Power, Enjoyed articles on fluorescent lighting. I have a mostly 24 VDC system, but do have one AC circuit powered by a Heart Interface 300X inverter. There are two 40 Watt tiny spotlights on this circuit, on 2 tracks about 5 feet over the kitchen counter. I use them for maybe an hour a day. Would I save much electricity by replacing them with the EL-R11 lights you describe? I don't have a battery charger, so in the winter I try to use as little power as possible. Use candles and Aladdin lamps and only watch enlightening TV programs. Charles Johnson, Marysville, CA

*The two incandescent bulbs consume about 80 watt-hours daily. Two Osram EL 11-R compact fluorescents would consume about 22 watt-hours daily, and provide 20% more light. You would save 58 watt-hours daily, and that's the average output of about 1/4 of a PV panel. The Osrams with built-in reflectors are just the ticket for track lighting. The parabolic reflector works better than any I have ever seen. It provides even light throughout its beam. RP*

## Desert Pumping

Dear Home Power, You have a great magazine. I read it all the first day I receive it.

My wife and I own a lovely desert camp site in Arizona that we visit every year, sometimes more. We have a well 500 ft. deep and water at about 300 ft. I would like to use solar power for pumping. Could I use stacked submersible pumps in the pipe? One at the lower setting and one half way up and add solar panels for the extra pump? Would this be feasible? Has it ever been tried? Would like to see something in Home Power about this. Robert R. Conn, Rio Linda, CA

*Solarjack (602-428-1092) is making submersibles that will pump 300 feet of well. Solar pumping has reached the state where 300 foot wells can be pumped with a single sub pump. Over this depth, jack type pumps can lift water from over 800 feet down. All run on PVs- from one to eight modules depending on depth and flow. RP*

## Aleutian Hydro

Dear People, We recently bought a self-sufficient homestead in the Aleutians. The past year or so we've been doing a lot of foundation work, backtracking that is, trying to figure out just what we have. I've made some electrical breakthroughs the past few days since finding a few old copies of Home Power. Up to this point we (and the previous owner/creator) had tried to stay away from any electronic gadgetry. Our Tethill water turbine is 100 years old this year. We float 76 Ni-Fe Edison cells (115VDC) and we use the surplus off the generator for electric heat and to charge a 12v system for radios, stereo, etc. I'm awaiting the arrival of a Trace 2012 inverter so we can use a computer and peripherals. Also in the works is rejuvenating a wind system to interface with the hydro. We have a few weeks in the dead of winter and a few weeks in early summer where the creeks are low.

The problem is finding a wind generator that will withstand very volatile Aleutian weather. We've had six 100 knot-plus breezes in just the past six months. We would like to have the extra juice to keep the greenhouse going in the winter. Otherwise, we're quite comfortable living within the confines of the energy budget freely provided here. So you can see I could use the whole gamut of AE information - basic theory/wiring to creative interfacing. I see that is what you offer so I've included some subscription money. I've gotten some good leads, in HP, I'm pursuing concerning efficiency freezers. Salmon and berry season is around the corner and we're looking forward to making a freezer for next season. P.S. Have

you ever reviewed books relevant to AE issues? I'd like to see a page or so devoted to some such reviews.  
Cheers, Buck Laukitis, False Pass, AK

*You bet, we've been doing reviews of books and periodicals for a while now. Check out the back issues. On the subject of wind machines that can take it— talk to Mike Bergey at Bergey Windpower, 2001 Priestley Ave., Norman, OK 73069 • 405-364-4212. Every wind maniac I talk to tells me that Mike's machines are survivors. RP*

### **No Soap Job**

Howdy Folks, The back of the subscription form got me started, and well, I guess I should be more thorough. A couple of years ago I saw an Australian program "Beyond 2000". They featured a vignette about a professor from Hong Kong? Tokyo? Who had developed and applied for some International patents on an ultrasonic clothes washing machine that used billions of agitating microscopic bubbles to dislodge oils, dirt and fatty acids from cloth, while using no soap whatsoever (no ecological effluents) and less water and less electricity than conventional methods. Every major soap company in the world had approached him and offered to buy his technology, at that time, he had refused, - this man should win the Nobel prize for Practical Application of Physics and Engineering - and in no AE catalog to date have I seen even a prototype unit. They do work, today, in the fields of cleaning jewelry and also optics. If pursued by AE folks, our evergrowing market would make this available, slowly but surely to everyone, and the precious resource of clean ground water (which the need of by the year 2005 will double-globally) could be saved and not further ravaged. All life is based on water - land life, fresh water - it's the juice of life. Many people in the conservation group, Trout Unlimited, would jump at the chance to see progress in this area.

If you have any info in this area, please print whatever - mucho important.

Also any info on the fuels cells that were used in Skylab Hydrogen/Oxygen or those being developed north of you, by Ballard Power Systems, in Vancouver, B.C. that have energy densities 2 1/2 greater than previously obtainable.

I will be sending a profile of my residential system soon. For a climate of 4.1- 4.3 mean annual hours of sun per day, with extended periods of overcast in Jan., Feb., usually 9-11 days.

Sorry this letter is so sloppy, but I don't have a computer printer yet. P.S. Although my smarts tell me to be

doggedly pessimistic about city life, city stuff, I still believe in the Green Dream. It is the only choice 4 me. I study electrical engineering and hope to make a life of it. Thanks for your achievements.  
Dan Duffield, Imperial, MO

*Well, Dan, you've got more questions than I have answers. On ultrasonic cleaning of clothing— why not? The savings in water (and hot water at that!) are obvious. How about it readers, anyone got info on giving the jeans a dose of ultrasound? Some info on fuel cells in this issue on page 29. I'd like to know more myself. RP*

### **DHW Parts**

Dear Home Power, Greetings! In light of President Bush's energy policy (what a joke) my wife and I see your publication as the best source of workable and renewable sources of energy. It appears that when the government determines a way to tax non-nuclear, renewable sources of energy, then and only then, will they support alternate sources of energy.

I am writing to you to see if you folks can steer me in the right direction. I have acquired an instantaneous water heater that needs some minor repair and alteration. This unit is manufactured by Thorn EMI and has a model number of TL 200. I need to know if you know where I can get parts for it. In particular, it needs a controller valve and I need to change the heater from its current natural gas set up to propane. I would appreciate any information you can send to me.

I look forward to receiving HP again after a year's absence. Keep up the good work.  
John McGonigal, Ft. Jones, CA

*Sorry, I can't locate that heater in any of my literature. How about it, readers, anyone know where to get parts for the Thorn EMI TL 200? RP*

### **Change of Winds**

As a new subscriber to HP I know you are asked to help prospective users of solar and wind with consultation, leading on to the best or most economical solutions.

This location is open to sun so solar panels (photovoltaic) should provide power for Amateur Radio and a few simple lights. I also have two wind generators at my disposal. One is a 150 watt wind charger (12v) the other an older gear driven 1200 watt (32v). At present I have taken down the 150 watt for maintenance, and have decided that its location is not good for the amount of available wind. The tower is 40' up on a pole. I have a 70' free standing steel tower ready for erection. It will be 200'

circuit loop to this cabin, a double of the distance of the smaller one, but higher, both ground wise and aerial height.

I'm troubled with the incompatibility of 32V to my 12v battery "Ham" radio. I don't want to use the 32v system unless it can be adapted to use directly with the 12v system gear.

It also looks like maintenance, gear box, pull chains, etc. can be a problem, unless a person likes to work at 70'. There are periods up to 30 days when temperatures are well below zero - so batteries sustain these temps while away. The place is remote - too far to pack out gear for warmth. No roads, but a good wind and solar site. This location is as close to a mountain top cabin as you can get in Northern Minnesota.

I will buy new wind gear if my fears of incompatibility (12v vs 32v) and maintenance are as bad as I fear. What to do!

Thor Nordwall, Ely, MN

*You need to talk to the Wind Wizard, Mick Sagrillo at Lake Michigan Wind and Sun, 3971 East Bluebird Rd, Forestville, WI 54213 • 414-837-2267. He can give you straight info about reliable wind power and the equipment you now have. RP*

#### What Questions

Would like information on: What automatic washers work best on Trace 2012? What color TVs, 20" or larger, are the most efficient on 2012? Information on good FM antennas. How far can a 12VDC ballast be mounted away from the tube? What VCRs work well or poor on Trace 2012? Are there 110 AC brush motors available for automatic washing machines? How can radio frequency noise in a telephone caused by Trace 2012 in standby mode be eliminated? Thanks.

Chris Borggren, Weaverville, CA

*See article on page 44 of this issue- its got the straight dope on washers. Look on the back of the TV set for the power consumption figures- that's about what it will consume from the inverter. The top of the line Radio Shack VHF/FM TV antenna (RS#15-1654 for \$59.95) works very well in fringe locations. Keep the 12 VDC ballast as close to the fluorescent as possible, if you don't you'll get RFI. Almost all VCR will work well on the Trace, some are noisy so get return privileges from the store when you buy it. In general, the Mitsubishi and Panasonic models work well. To stop your Trace from getting into your telephone- relocate the phone wiring. You have most likely run the telephone wiring parallel and close to the house power wiring. Keep the two as separate as possible. If the phone line must cross an ac wire, then*

*make it cross at a right angle and then go for at least four feet before running parallel to the 120 vac power wiring. You can also replace your phone wiring with coaxial cable, which will reduce the interference. RP*



**Put your favorite head into a**

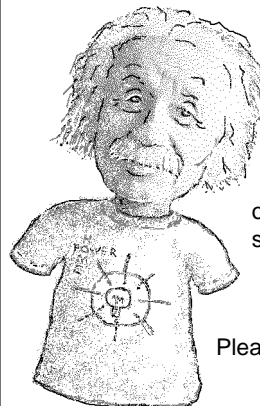

## HOME POWER T-SHIRT

High Quality, All Cotton, Heavy-Duty, T-Shirts with the words **HOME POWER** and our Logo on the front. Electric blue t-shirt with sun yellow logo.

\$14.

Shipped First Class anywhere in the known Universe. Please specify size (S,M, L or XL). Allow 4 weeks for delivery.

Home Power Magazine  
POB 130, Hornbrook, CA 96044

Small Print: Sure HP makes a buck on this deal. Ya want to know where the money goes, well, you are holding it in your hand at this very moment. Thanks, the HP Crew.

# Ozonal Notes

## Trailhead Supply EDTA Recall Alert Stan Krute

In HP#21, I wrote about my experiences using EDTA from the Sigma Chemical Company to help revive tired lead-acid batteries. After the article, on page 39, Richard Perez gave some EDTA access data: three suppliers we had spoken to who said they were selling the same 99.5% pure tetrasodium salt: hydrate EDTA that we had used.

A few weeks ago, I received phone calls from two HP readers who had ordered their EDTA from one of those suppliers, Trailhead Supply. They both said that their EDTA had not dissolved in water. It should have, as my article pointed out. One reader sent me the EDTA he had purchased from Trailhead. His EDTA smelled roughly like mine (pee-yoo!!!), but looked different: mine was like dry white sugar, his like rougher wet white sugar. I heated up two quarts of distilled water to 125° Fahrenheit, put it into two clean mason jars, added 12 Tablespoons of my Sigma EDTA to one, and 12 Tablespoons of the Trailhead EDTA to the other. My EDTA dissolved in 38 seconds. The Trailhead EDTA settled to the bottom of its container, and sat there for a day, until I disposed of it.

Karen Perez and I both spoke with Kent Scott of Trailhead Supply. He receives his EDTA from a local chemical distributor in bulk, then repackages it. That's how he can offer a price that's half the price of the other two suppliers we listed in HP#21. His first bulk batch had been fine, he said. It was from

the CIBA Company, and was 99% pure. For the second batch, he said, he asked the chemical distributor to get him something that was 99.5% pure. He received it in an unmarked, unlabeled bag. He shipped out about 25 pounds of it, he said. After receiving complaints, he had found out what I had: it was not the right stuff, and wouldn't dissolve. He said he'd added some to a battery, and had noticed no ill effects. He said his distributor was trying to figure out what it was Trailhead had been given. He is now using the CIBA EDTA again.

Kent said he will send the CIBA EDTA to anyone who received the funky mystery material. He does not have records of everyone who bought the bad batch, so said he was happy to have HP print a recall notice, which we are doing.

So: if you ordered EDTA from Trailhead Supply, and it doesn't dissolve in water, get in touch with them. **DON'T ADD IT TO YOUR BATTERIES !!!**

My own thoughts here: Kent seemed like a nice enough fellow. He wants to make good on the bad EDTA. And his EDTA price is less than anyone else's by half. I assume he will no longer ship out chemicals that come to him unlabeled. For myself, though, I'll continue to pay the extra bucks and get my EDTA from a supplier who will ship it in the original labeled chemical company container. This may be superstitious of me, but, hey, we're dealing with batteries here, the sine qua non of pseudo-science.

### Access:

Stan Krute, C/O Home Power, POB 130, Hornbrook, CA 96044.



Don't let this Season of the Sun pass you by!

Get the new revised edition of Heaven's Flame,  
a Guidebook to Solar Cookers by Joseph Radabaugh

*Heaven's Flame*

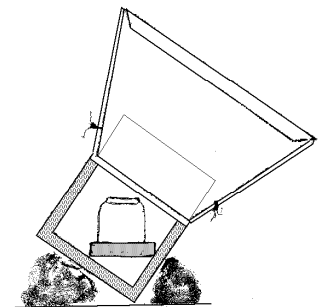
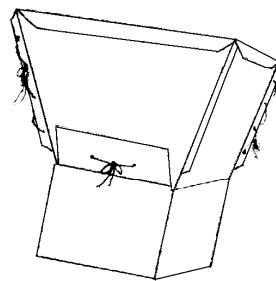

Heaven's Flame gives an in-depth look at solar ovens. It provides plans to build an inexpensive, efficient solar oven from foil, glass, and cardboard boxes. Joseph's fifteen years as a solar oven designer and solar cooking enthusiast have coalesced into an informative primer that will spark your interest and get you cooking with the sun fast. 96 Pages, 5.5" by 8.5" format, 11 photographs, and 50 illustrations. Full color cover and sewn binding. Built to last. Printed with soybean inks on recycled paper. Available for \$10.00 postpaid, please allow six weeks for delivery.

 **HOME POWER** 

POB 275, Ashland, OR 97520



# Home Power's Business

"The man who on his trade relies  
Must either bust or advertise."  
Thomas Lipton - 1870.

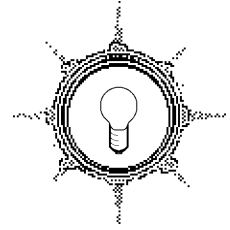

## Display Advertising

|              |         |              |
|--------------|---------|--------------|
| Full Page    | \$1,200 | 67.5 sq. in. |
| Half Page    | \$672   | 33.8 sq. in. |
| Third Page   | \$480   | 22.5 sq. in. |
| Quarter Page | \$377   | 16.9 sq. in. |
| Sixth Page   | \$267   | 11.3 sq. in. |
| Eighth Page  | \$214   | 8.5 sq. in.  |

Maximum Vertical Ad size is 9 inches  
Maximum Horizontal Ad size is 7.5 inches

We can set up and lay out your display ad. Camera ready advertising is also accepted. For full color ad rates and demographics, please call us.

Long term display advertising is discounted, so buy ahead and save 10% on 3 insertions and 15% on six.

Home Power is published bi-monthly. Ad Deadline for the June / July 1991 issue (HP#23) is 15 May 1991.

Call **916-475-3179** for further details.

## International Subscriptions

Due to the high cost of international mailing & packaging, we must charge more for copies of Home Power that are mailed anywhere that doesn't have a US ZIP CODE.

### 1 YEAR- 6 ISSUES

#### INTERNATIONAL RATES:

Canada: Northern Alternate Power Systems, POB 14, Pink Mtn., BC V0C 2B0. \$22. Can.

Mexico: Air- \$16. Surface- \$14.

Central America, Bahamas, Bermuda, Columbia and Venezuela: Air- \$21. Surface- \$15.

South America (except Columbia and Venezuela),

Europe, North Africa: Air- \$27. Surface- \$15.

Asia, Australia, New Zealand, Pacific Ocean Islands,

Africa (other than North Africa), Indian Ocean Islands,

& the Middle East- Air \$34. Surface \$15.

### All payments in U.S. currency ONLY!

Surface shipping may take up to 2 months to get to you.

All issues shipped in mailing envelopes. If you have friends with a US Zip code who regularly send you packages, then we can ship them an extra copy for forwarding to you for \$10 U.S. yearly.

## Mercantile Advertising

One insertion per customer per issue.

We typeset all ads. We do the best we can to make your ad look good. If you send too much copy, then you're bound to be disappointed. Flat Rate \$80.

Advance payment only, we don't bill Mercantile Ads.

Your cancelled check is your receipt.

## Back Issues

Back issues through 20 are \$2 each (\$3 each outside U.S.), while they last. Sorry no more Issues # 1, 2, 3, 5, 6, or 7 are available. Back Issues of #21 & #22 are \$3.50 each (\$5 each outside U.S.). All back issues shipped first class mail in an envelope or box.

Home Power Magazine, POB 130, Hornbrook, CA 96044

## MicroAds

MicroAd rates are 10¢ per character. Characters are letters, numbers, spaces & punctuation marks. \$15. minimum per insertion. Send check with your ad. We don't bill MicroAds.

## Home Power Magazine for Resale

Quantities of Home Power Magazine are now available for resale by newsstands, bookstores, energy businesses, and others. Please write or call for the specifics.

## First Class Home Power

Home Power Magazine (6 issues) via FIRST CLASS U.S. DOMESTIC MAIL for \$20. Many of you have asked for faster delivery of your issues. So here it is: FIRST CLASS HOME POWER. All First Class issues shipped in an envelope.

## Second Class Home Power

Home Power Magazine (6 issues) via SECOND CLASS U.S. DOMESTIC MAIL for \$10. Second Class is forwardable, but please let us know if you move! Please allow eight weeks for processing your subscription.

# Home Power MicroAds

**Rates: 10¢ per CHARACTER, include spaces & punctuation. \$15 minimum per insertion. Please send**

**INVERTER FOR SALE.** Heart model HF12-1200 with 50 Amp battery charger. 12 volts DC in and 1,200 Watts of 120 vac out. Excellent condition. Need bigger inverter. \$695. 916-475-3394.

**JACOBS WIND ELECTRIC** replacement parts, new blades, and blade-actuated governors. We make replacement parts and have new blades for most all wind generators, pre-REA to present models. Many used parts, too. Lots of used equipment available: wind generators, towers, both synchronous and stand alone inverters, and Aermotor waterpumpers. Best prices on TRACE inverters and Bergy Wind Generators. Whisper 1000, \$1260 and we pay shipping. Trade Wind's wind odometer for \$140.00, delivered. Information: \$1; specify interests. Lake Michigan Wind & Sun, 3971 E Bluebird Rd., Forestville, WI 54213 Phone 414-837-2267.

**FOR SALE HEART H12-1200X**, 1200 watt ultra high efficiency inverter. 12VDC input, 120vac output, regulated RNS voltage. Reactive load compatible. Has 50 amp battery charger, standby mode for use as an emergency system. Excellent condition. \$700. 916-475-3428

**THE LAND NEWSLETTER** - Buying, selling, and sharing land with respect. Special opportunities, upcoming events. \$10./year or Sample issue \$1.00. PO Box 849 Glen Ellen, CA 95442.

**CEILING FANS**, 3 and 4 blade models, 12 VDC, draws only 0.4 amp, 44" diam. oak blades. Send S.A.S.E. to R.C.H., 2173 Rocky Creek Rd, Colville, WA 99114

**PORTABLE DOMES AND GREENHOUSES:** 20 min. up! Proven performance. Many models. Cat. \$1. SHELTER SYSTEMS, PO Box 67-HP, Aptos, CA 95001 (408) 662-2821

**1989 GUIDE TO UNUSUAL HOW-TO SOURCES.** Describes 50 periodicals & handbooks on backyard tech, camping, crafts, finding new friends, gardening, home education, low-cost shelters, travel, woodstore, etc. All addresses are included. Free for SASE. Light Living Library POB 190-HP, Philomath, OR 97370

**HOW TO BUILD THE 5,000 GALLON FERRO-CEMENT WATER TANK** that needs no building permit and lasts 7 generations. Complete full sized step by step instructions. \$10.00 RIDGEHAVEN, POB 849, Glen Ellen, CA 95442

**PURE CASTILE & VEGETARIAN SOAPS.** Handmade in an AE environment. We also have hard to find natural bath & body care products. FREE catalog: SIMMONS HANDCRAFTS 42295 AE, Hwy 36, Bridgeville, CA 95526

**HYDROELECTRIC SYSTEMS:** Pelton and Crossflow designs, either complete turbines or complete systems. Assistance in site evaluation and equipment selection. Sizes from 100 watts to 5 megawatts. Manufacturing home and commercial size turbines since 1976. Send for a free brochure. Canyon Industries Inc., P.O. Box 574 HP, Deming, WA 98244, 206-592-5552.

**INVERTER SALE** Before buying your Trace Inverter, check with us. Our prices are hard to beat. Send S.A.S.E. to R.C.H., 2173 Rocky Creek Rd., Colville, WA 99114.

**SURPLUS SOLAR** collectors, liquid, flat-plate, 3' X 8'. \$120 ea. Get info:

Community Builders, 1494 Cedar, Green Bay, WI 54302.

**INEXPENSIVE 12V LIGHTING.** Use car bulbs in 110 fixtures with our nifty adaptors (See HP4 Things That Work). \$5 ea, dealer discounts. AE-powered home industry. Northern Lites, POB 874-HP, Tonasket, WA 98855

**SOLAR MIND** - Newsletter with a holistic view to appropriate transportation, technology, and mind. Also electric vehicles and parts listings. Send \$3 to: Stevenson, 759 S. State St. #81, Ukiah, CA 95482

**STATPOWER PROWATT 600 INVERTER FOR SALE.** Used only two months for testing. List price \$499, will sell for \$350 and ship via UPS free. Home Power, POB 130, Hornbrook, CA 96044 or call 916-475-3179

**CHINESE ONE CYLINDER DIESEL TRACTORS.** \$3595 - China Farm Machinery Co. 23985 Rolling Meadows, Perris, CA 92370, 714-657-0379 Fax 714-657-8120. In MI, IL, IN, OH, SC, & FL. Carl P. Russell 11895 Frost Rd. Freeland MI 48623 Phone (517) 781-0007\*(517) 781-2859\*Fax (517) 781-5999. Need Reps & Dealers. Send \$20 for video, refund on first order.

**COST + 10%!** No price games, just the lowest solar markups in USA. \$5 catalog. Abraham Solar, 14176 Richmond, Amarillo, TX 79118, 806-622-0512 Evenings

**ELECTRIC CARS:** Convert gas car to electricity. \$5.00 catalog or \$37.50 catalog & step-by-step manual, recommended by Electric Auto Assn. & Stanford University. Electro Automotive, Box 1113-HP, Felton, CA 95018

**SOLAR WATER HEATER.** Antifreeze system with photovoltaic pump. You install and save. Illustrated instructions, 96 page manual/catalog \$10.95 (refundable). Save On Solar, Inc., Dept. HP, 6905 White Rabbit Road, Battle Creek, MI 49017.

**GAS REFRIGERATORS**, solar electric systems, kits with complete directions. Photovoltaic modules, inverters, batteries. Great mail order prices, plus expert assistance. Will beat almost any sale price. \$3 catalog. New revised 1991 SOLAR ELECTRIC INDEPENDENT HOME BOOK. 200 pp. 8 1/2"x11", 80 diagrams, 25 photos. Installation guidelines and schematics, design, maintenance, for super-efficient Photovoltaic systems for independent homes. \$18.95 (includes shipping and catalog). Fowler Solar Electric Inc., Box 435, Worthington, MA 01098. 413-238-5974.

**MAKE FREE HYDROGEN FUEL** from rain water and your renewable power source. Send for plans to make your own gas generator or buy a ready made Water Electrolyzer. For plans and information, enclose \$1.00 to - HYDROGEN WIND, INC., Lineville, Iowa 50147

**ELECTRIC FROM WOOD FUEL** using a simple, under \$50 weekend project gas producer to fuel your gas engine generator. Detailed manual \$10.0 Ppd. includes heat cogeneration. Gene A. Townsend, 36515 Twin Hawk Lane, Marana, AZ 85653

**FOREST FIRE WILL DESTROY** hundreds of homes and cabins this year. You can prepare yourself with knowledge most firefighters are unaware of. Send large SASE to: Dragon Slayers Inc., PO Box 669/HP, Selma, OR 97538

**EDTA RESTORES SULFATED BATTERIES**, send \$10/lb. ppd. Catalog and review of unusual self-sufficiency equipment I use myself. \$1 (credited) plus SASE. Trailhead Supply 325 E. 1165 N., Orem, UT 84057

**FOR SALE Solar Water Pump.** Jack type, pump 1000', includes 600 watt current booster, bridle and motor. Built to last a lifetime, \$900. Also many Jacobs parts and assemblies, Larry Elliot, 63600 Deschutes Mkt. Rd., Bend, OR 97701 503-388-2053

**WIND GENERATORS 300 to 5KW**, converters 12V/110vac, motor gen sets, vehicle fuel saving adaptors. Info \$3.50. S. D. Systems, RR#4, Eganville, Ont., Canada K0J 1T0

**FRESOURCE Solar Water Heating Appliance** produces 50% to 80% of any family's water heating needs. Request our water heating factsheet.



FRESOURCE Post Office Box 2001 Charlotte, North Carolina 28247 (704) 542-2808

250+ UNCONVENTIONAL TECHNOLOGIES! Suppressed, Dormant & Emerging Inventions, Discoveries & Experiments! Air Wells (Collect Water from Atmosphere!), Electro-Culture 300% Increased Growth With Battery! High-Mileage Devices For Autos! Amazing Archives Catalog! Send \$2: Rexarch, Box 19250, Jean, NV 89019

JOIN CITIZENS FOR CLEAN ENERGY! Help Promote: Appropriate Energy Technology - Energy Self-Reliance. Support Solar/Hydrogen Energy Demonstration Projects. Solar/Hydrogen - The environmentally safe and politically secure alternatives to fossil fuel. 1991 Charter Membership includes discounts on upcoming Videos, Publications, and Newsletter: Send \$10 to CCE P.O. Box 17147 Boulder, CO 80308

RAM WATER SYSTEMS. Hydraulic Rams use flowing water to pump uphill stream or spring. Send amount of flow, fall, and lift for proposal to Herb Barberie, 8820 Rapid Lightning Rd, Sandpoint, ID 83864 208-263-0366

MT SHASTA AREA 20 ac. unimproved Hwy 97 & Big Springs Rd, out of Weed, CA near Golf Resort 360° view Excel. solar \$12,900 cash or assume 415-985-7082

TWO BEDROOM HOUSE on 2.2 acres within commuting distance of Seattle and Tacoma. Beautiful view of Mount Rainier and the Orting Valley. Completely self-sufficient power system with Solar, Wind and Hydro operating. Has solarium and small orchard. \$60,000, 15 down and owner will carry contract. 206-833-6160 11406 Aub-Blk Dia Rd, Auburn, WA 98002

FINGER LAKES - Seeking minimal gas refrigerator. K. Engel Telmani Farm, RD2 Trumansburg, NY 14886

GLOBAL MARKETING of your renewable energy product or service. We assist you in developing markets and strategies. Visit our hut at SEER in Willits, CA Aug. 9, 10, 11 1991 and/or write/fax/phone Jack Boone & Associates Boone Station, Fort Bragg, CA. 95437. Phone 707-459-0730. Fax 707-459-4420 for a free initial consultation.

HARNESS THE WIND...it's yours and it's free. MORIAH POWER brings you a unique vertical-axis wind turbine of space-age efficiency--combing both the venturi and magnus effects to deliver significant power in low wind speeds. Information packet, \$6; VHS tape \$20. Send check or money order to Moriah Power, 16 North 400 East, Orem, UT 84057. No CODs. (801) 224-4686

BEST POWER INVERTER B32-3000, 32VDC 3000 with load demand and tech documents \$750. Jacobs 10KW Wind Generator with 100' Rohn SSV tower \$8500. Whirlwind 4120I 4KW wind energy system with 60' Rohn SSV tower and utility interface controls \$4,750. Call The Wind Electric Shop, RI • 401-635-4766 • 5-6 P.M. EST

BOOKS. Practical, Affordable Books for Do-It-Yourselfers in Solar Energy and Energy-Efficient Housing. Catalog \$1.00 credited on first order. Save On Solar, Inc., Dept. HP, 6905 White Rabbit Road, Battle Creek, MI 49107.

WANTED: 1800 RPM 8 KW or bigger generator w/o engine. Call Dave collect 808-329-5029

HOME POWER BACK ISSUES. A limited number of the original magazines are available for issue #'s 1 thru 8. Now you can complete your set of Home Power Magazines. USA ppd. prices are \$4 each or \$3 ea in quantities of 5 or more. Kansas Wind Power, RT1, Holton, KS 66436. 913-364-4407

DC-DC CONVERTOR 20-56V in 12V out adj. 85% eff. Brand New (\$469) \$350. 36V adj. transistorized regulator for Jacobs etc. \$150. Heart HF 12-300X as new in box \$275. Aeolian Kinetics Wind Prospector \$150. 614-946-6611.

WANTED "BEST" INVERTERS "M" Series 6000/12000 36/48/120V Working or not Call J. SEIBOLD (702) 597-2245, 241 E. Reno Avenue, Las Vegas, NV 89119

LOOKING FOR 20 TO 40 ACRE mountain homestead in Northern Calif. with creek or spring. Please reply to Woodward, P.O. Box 6771, Malibu, CA 90264

WINCHARGER GIANT - Model 11010, 110VDC, 1500W, Mint Condition Original Machine, Complete, Plus 70' 3-Leg Freestanding Tower, \$3800.00. WITTE DIESEL GENERATOR SET-Model BD 7.5 KW, 900 RPM, 240/120VAC, Burns 1/4 Gal/Hr! Runs Perfectly! \$4500.00 916-265-3713

FREE RENT/ret. couple to share lg. 6 bdrm, log mountain home in exchange for occ. caretaking home/pets. Must like rustic lifestyle, fishing, hunting, pets. Send SASE, RESUME, photo, Ref., to Cossin, Box 56, Holman, NM 87723

JET PUMP 12/24 volt 300 watt McDonald 1500DJ. Barely used. \$750. Heart Interface Inverter 24V 2500 watts Model HF24-2500X. \$750.00 Jean Smith, Star Route Box 55-0, Oroville WA 98844. (509)485 3900

MUST SELL. Husband has progressive illness. Remote mt. home, 3 bdrm 2 full baths. All electric 24V sys run off 12 PV panels on tracker, 8 forklift batteries w/gen. backup. Good house well. TV sat. system. 24'x24' cabin. Water Ram irrigation w/storage tanks. On 40 acres-8.5 mi. from town. Add. 280 acres. opt. Write Roger Erickson POB 337 Del Norte CO 81132 NO Phone

FOR SALE used Bowli N.E. composting toilet, good condition \$575 including shipping. GES, 8811 Breeding Rd., Edmonton, KY. 42129 (502) 432-2858

PORTABLE COMPUTER FOR SALE Zenith SupersPort; 20M hard disk; 640K RAM; 3.5" DS/DD disk drive; Supertwist LCD screen; 12.5V 2.5AH battery pack; carrying case; \$1600 firm. Joel Davidson 213-202-7882.

40 ACRES, NEAR ASHLAND OREGON, view, solar, hydro potential, springs, creek, road in, utilities avail., nice property 65,00/terms. Also, 40 acres near Grants Pass, new 3 bdrm passive solar home, lg. shop, organic garden, fruit trees, satellite dish, springs, creek, solar hydro potential, more 170,000/terms. INFO write Eric Weiss, POB 1226, Grants Pass, OR 97526 503-488-2614

USED M51 36W PV panels in boxes of 4 - \$175 ea. Other panels available new & used. Also new & used Trace & Heart inverters. We specialize in PL QH & compact fluorescents. Send SASE for current listing of used equipment. DC compressors for refrigerators also available \$240.00 Complete catalog \$5.00 includes used listings. Write: Alternative Power & Light Co., 128 Weister Creek Road, Cashton WI 54619

MOVING SALE Natural Power is moving to a new facility. Must dispose of the following cheap: (2) 8KW Gemini inverters; (10) NPI Model A25 Wind Energy Monitors (unit estimates wind turbine energy production given input by anemometer, included); (1) 60 foot four leg turbine tower, requires disassembly; parts to build (50) one KW alternators; misc electronic parts. Natural Power Inc. 342 Lyndeboro Rd. New Boston, NH 03070 • (603) 487-5512.

12 VDC HAS ADVANTAGES. Complete, working system. Two banks of Kyocera Solar Panels, (16 total at 59 watts each). One Tracker. Two inverters, 120 VDC in, 3000+ watts out. 120 VDC charger. 20 batteries, 6 volt. All or part. SW Ore. (503) 899-1226

JACOBS WIND ENERGY SYSTEM 10KW 2-Industrial battery chargers 40-Trojan L-16 batteries 10KW inverter all controls including remote control and 100 amp rollover switch. Complete system \$15,000. Call Bill Thomas (916) 832-5607 or (916) 832-5106



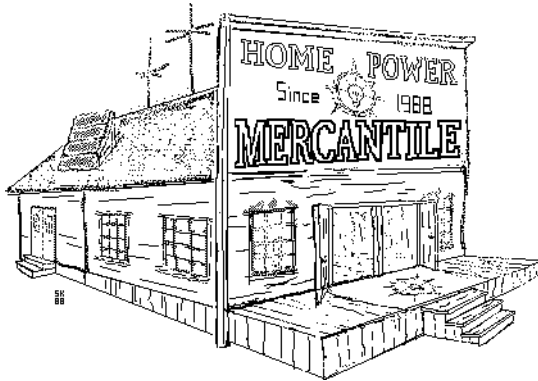

One insertion per customer per issue. We typeset all ads and do the our best to make your ad look good. If you send too much copy, then you're bound to be disappointed. Flat Rate \$80. Advance payment only, we don't bill Mercantile Ads. Your cancelled check is your receipt.

**\* CUT YOUR ENERGY COSTS \***

OSRAM DELUX EL COMPACT FLUORESCENT LIGHTS

EL-11 \$21.50 EL-15 \$22.50 EL-20 \$22.50

KYOCERA 51 WATT PV MODULES \$319.00

INVERTERS - PV SYSTEMS - CHARGE CONTROLLERS - BOOKS

CATALOG/GUIDE \$4.00 (REFUNDABLE) VISA-MC

SOLAR ELECTRIC P.O. BOX 934 TRAVELERS REST, SC 29690  
(803) 298-0209

**SUNICA NICAD BATTERIES**

*"As dependable as the rising of the sun"*

FLUKE MULTIMETERS

AC/DC CLAMP-ON PROBES AND ACCESSORIES

**•NO SALES TAX•**

Off the grid since 1974. Workshops & Seminars on AEPower.

**Holistic Institute of Montana, Inc.**

3000 Mill Creek Road, Niarada, Montana 59852 • 406-883-4009

**INEXPENSIVE 12 VOLT LIGHTING**

Use car bulbs in 110VAC fixtures with our nifty adaptors

See HP#4- Things That Work! \$5 each, dealer discounts.

*AE-powered home industry.*

Northern Lites, POB 874-HP, Tonasket, WA 98855

**Sunrise Coffee**

*True Solar Energy for your Cup!*

I custom roast the finest class coffees to the peak of perfection.

Types to choose from: French, Columbian, Kenyan, Sumatra, Guatemalan, Panama, Mexican, Costa Rican, Viennese, Sunset Rose, Fire Mountain and may more.

Five pounds of your choice, roasted the way you want it for \$32.50 postpaid.

**Sunrise Coffee Company**

POB 319, Port Townsend, WA 98368 • 206-385-4117

## Index to Advertisers

- 12 Volt Products - 67
- Active Technologies - 58
- Alternative Energy Engineering - 100
- Alternative Power & Light - 67
- Alternative Transportation News - 83
- Ample Power Company - 72
- Atlantic Solar Products - 10
- Backwood's Solar Electric - 37
- Bergey Wind Power - 34
- Bobier Electronics - 49
- Burden's Surplus Center - 31
- C. Crane & Company - 67
- Cimarron Mfg. - 48
- Cruising Equipment - 66
- Drake Services - 43
- Earth Rising Productions - 90
- Electron Connection - 99
- Energy Depot - 13
- Energy Specialists - 82
- Energy Systems & Design - 78
- Folk Water Ram Pumps - 58
- Great Lake Renewable Energy Assoc.- 93
- Harris Hydroelectric - 82
- Heaven's Flame - 94
- Heliotrope General - 40
- Home Power Magazine - 95
- Hydrocap Corp. - 89
- Hydrogen Wind, Inc. - 34
- Independent Energy Systems - 30
- Kansas Wind Power - 66
- Kyocera America - 25
- Lake Michigan Wind & Sun - 54
- Lil Otto Hydroworks - 78
- Midwest Renewable Energy Assoc. - 90
- New England Sustainable Energy Assoc.- 50
- Offline - 67
- Pacific West Supply - 14
- Photron - 31
- PowerStar Products - 14
- PV Network News - 78
- Real Goods Trading Co. - 2
- Renavair - 74
- SEER '91 - 90
- Simmons Handcrafts - 82
- Skyline Engineering - 40
- Soda Mountain Company - 50
- Solar Technology Institute - 90
- Solarex - 5
- SunAmp Power Company - 56
- Sunelco - 58
- Sun Frost - 56
- Sunlight Energy - 31
- SWRES - 69
- System Electric - 54
- The Power Company - 25
- Trace Engineering - 34
- Utility Free - 48
- Wattever Works - 48
- Wm. Lamb Corp. - 21
- World Power Technologies - 10
- Zomeworks Corp. - 56



Support HP Advertisers!

# PowerStar Upgradable Inverter!

Things that Work!  
Tested by Home Power

**UPG400-\$395.00**  
380 Watt Continuous!

**UPG700-\$495.00**  
700 Watt Continuous!

**UPG1300-\$795.00**  
1300Watt Continuous!

**Shipping included**  
**in Continental USA**

**PowerStar POW-200**  
**Inverter**

12 VDC to 120 vac up to 200  
Watts (140 Watts continuous).  
House current from your  
car/truck/RV/boat...

**Without a generator!**

**Our Price- \$ 129.00**

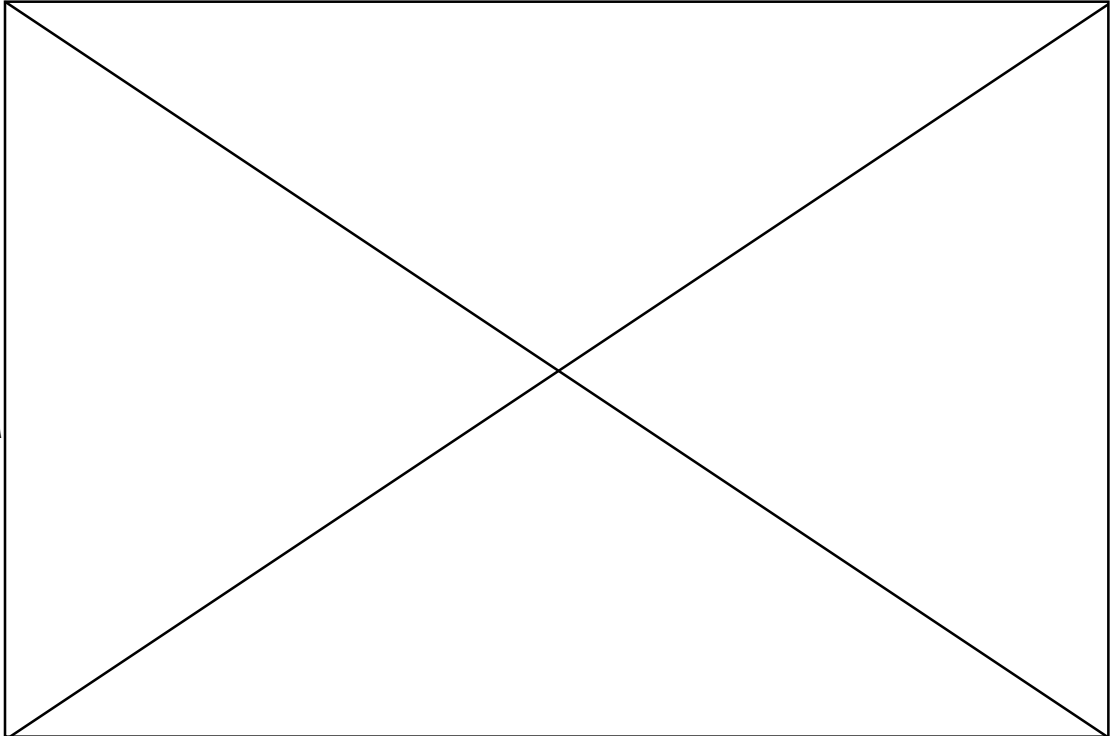

## TROJAN BATTERY

*America's most dependable batteries  
since 1925.*

**Trojan Deep-Cycle Batteries for home power systems**

**T-105 6Volt 217A/hr\* \$65.00**

\*20Hr. discharge rate

**L-16 6Volt 350A/hr\* \$165.00**

F.O.B. Sacramento, CA.

**L-16W (wrapped) \$215.00**

free delivery to outlets in  
Redding or Chico, CA and Reno, NV

**Power Inverters-Charge Controllers**

Trace Engineering-Heliotrope General-PowerStar

**Microhydro Electric Powerplants**

Lil Otto Hydroworks!-Harris Hydro-Powerhouse Paul

**Ample Power Company**

**Energy Monitor**

List Price- \$299.00

**Call today for Special Price!**

CA residents please add 6% Tax.

**SERIOUS DEALER INQUIRIES INVITED**

Join Electron Connection's growing network of home power dealers.

Write or call today for your dealer application.

**Electrical Usage Analysis and Power System Design**

We design, build, and install custom systems for your situation and lifestyle.

**CA Electrical Lic.#613554**



**ELECTRON CONNECTION**

**POB 203, HORN BROOK, CA 96044**

**916-475-3401**



ALTERNATIVE  
ENERGY  
ENGINEERING  
FULL  
PAGE

BACK  
COVER