

Simple and Reliable Solutions For Global Power Problems!

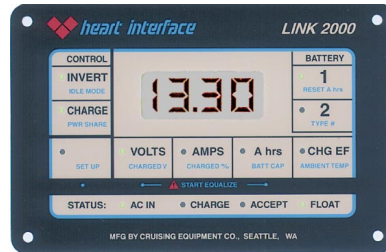

Millions of people lose AC power daily. Earthquakes, floods, hurricanes, ice storms, tornados, and other disasters can cause the grid to fail. In many countries the grid is so unreliable that there are a dozen power outages a day. The result...systems crash and business stops. A back up power system is the only insurance. Our system is simple: A Freedom Inverter/Charger supplies reliable AC power during outages and quickly recharges the battery when power is restored. The Link 2000, or the popular E-Meter, is used to monitor the system so you know exactly how much energy you have consumed and how long your battery will last.

Inverter Features

- ◆ UL Listed Models 750 - 2500 Watts
- ◆ Charging rates from 25-130 amps
- ◆ 120V & 230V, 50 & 60 HZ Models

Instrumentation Features

- ◆ Volts, Amps, Ahrs, and Time Remaining
- ◆ Learns Charging Efficiency
- ◆ Simple to Use and Install

Typical Back Up Power System

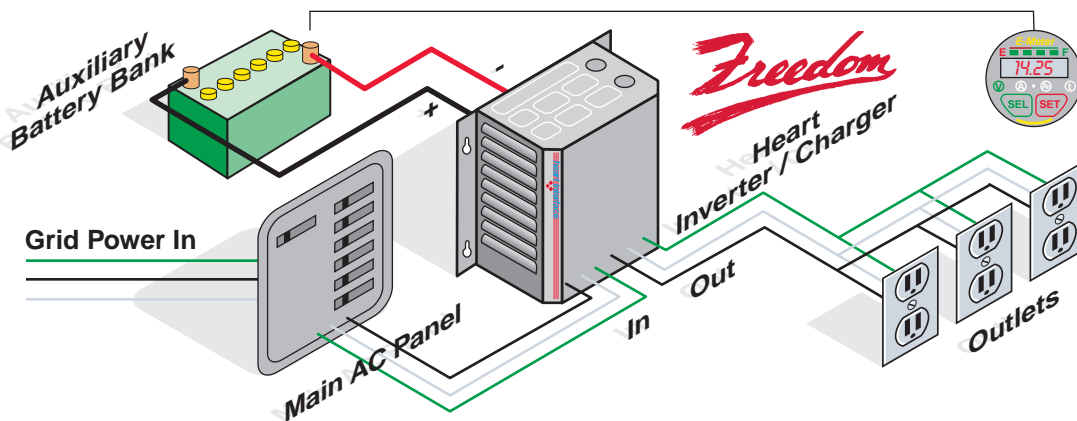

Things that Work!
tested by Home Power

heart interface World Leader in Back Up Power™

21440 68th Ave. S. Kent WA 98032 (206) 872-7225 Outside WA (800) 446-6180 Fax (206) 872-3412

Cruising Equipment

Visit our Web page at: <http://www.cruisingequip.com>

6315 Seaview Ave. N.W. Seattle, WA 98107 usa Phone: (206) 782-8100 Fax: (206) 782-4336

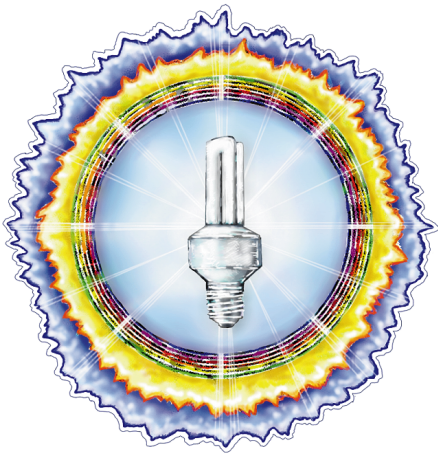

HOME POWER

THE HANDS-ON JOURNAL OF HOME-MADE POWER

Issue #54

August / September 1996

Features



- 6 On The Air**
Don and Sylvia Leutz power their FM radio station, KBYN, in the Sierra Nevada with photovoltaics. Don Loweberg details the decisions made during design and installation of this remote communications system.



- 12 Solar-Powered Cattle Saloon**
Saloon!? Well sort of. Rancher Don Golder uses a portable solar-powered jack pump to provide water for the cattle on his ranch in southern Montana.



- 16 Rolling PV...**
Don Kulha has equipped his Volkswagen bus with enough PV to run a good sized cabin. But his reasons are pure, clean computer camping.



- 60 Riding the Rails**
Thousands of miles of scenic, smog-free, shallow-grade fun. And you don't even need to bother with steering.

- 50 Prototype Flexibility**
Michael Hackleman exposes some trade secrets for designing EV projects from the chassis up.
- 53 Race Series**
Shari Prange begins a series exploring the details and classifications of the various electric racing events. Part one: Phoenix.

Fundamentals

- 34 The Grid**
Michael Perez lets us in on the workings of the big guys. This is the technical scoop, no politics here.
- 64 Confessions of a Battery Abuser**
We won't say who, but someone learned hard lessons about RE systems and the treatment of batteries. Maybe, if we're smart, we can learn from his mistakes.

GoPower

Features

- 22 You Can Do It!**
Greg Krush helps us keep it all in perspective. Everything you need can be provided simply and cheaply. He got started for under \$3,700.

Cover: The PV panels that power KBYN-FM and the broadcast antennae that gets it to the people. Story on page 6.

Homebrew

- 40 Slave Charge Controller** 
Wow! This circuit will use the brains of your existing charge controller while doubling the current output capacity.
- 44 Sundown Timer**
This timer project is triggered by nightfall then runs for a specified number of hours before resetting. Perfect for outside area lighting.

Things that Work!

- 68 ZANE International Fan Controller** 
This unit controls the speed, and direction, of 12 Volt ceiling fans.
- 71 Thermal Art**
Electric heater? Yup, and it fits almost any motif.
- 73 TriField EMF Meter**
Find those fields before they find you.

Columns

- 76 Independent Power Providers**
The utilities' policies on net metering change faster than we can publish magazines.

- 82 Code Corner**
John Wiles brings to light a potential for overcurrent on ac neutral lines in a multiwire branch circuit.
- 86 Power Politics**
We hear alot about California, but there is progressive energy activism happening throughout the country. Michael Welch discovers Wisconsin.
- 89 Home & Heart**
Kathleen is initiated into the world of alternative building materials at the Women's Natural Building Fair.
- 94 Book Reviews**
Aunt Carrie's War Against Black Fox Nuclear Power Plant by Carrie Barefoot Dickerson.
Energy Possibilities by Jesse S. Tatum.
- 96 the Wizard speaks...**
Who's Driving?

Regulars

- 4 From Us to You**
- 80 HP's Subscription form**
- 81 Home Power's Biz Page**
- 91 Happenings — RE events**
- 97 Letters to Home Power**
- 107 Q&A**
- 109 Micro Ads**
- 112 Index to Advertiser**

Access and Info

Access Data

Home Power Magazine
PO Box 520,
Ashland, OR 97520 USA

Editorial and Advertising:
916-475-3179 voice and FAX

Subscriptions and Back Issues:
800-707-6585 VISA / MC

Computer BBS:
707-822-8640

Internet E-mail:
hp@homepower.org

World Wide Web:
<http://www.homepower.com>

Paper and Ink Data

Cover paper is 50% recycled (10% postconsumer and 40% preconsumer) Recovery Gloss from S.D. Warren Paper Company.

Interior paper is recycled (30% postconsumer) Pentair PC-30 Gloss Chlorine Free from Niagara of Wisconsin Paper Corp.

Printed using low VOC vegetable based inks.

Printed by

St. Croix Press, Inc.,
New Richmond, Wisconsin

Legal

Home Power (ISSN 1050-2416) is published bi-monthly for \$22.50 per year at PO Box 520, Ashland, OR 97520. International surface subscription for \$30 U.S. periodicals postage paid at Ashland, OR, and at additional mailing offices. POSTMASTER send address corrections to Home Power, PO Box 520, Ashland, OR 97520.

Copyright ©1996 Home Power, Inc.

All rights reserved. Contents may not be reprinted or otherwise reproduced without written permission.

While *Home Power Magazine* strives for clarity and accuracy, we assume no responsibility or liability for the usage of this information.



Recycled Paper



Recyclable Paper



Lights at Night!

I've been living with solar electricity for over eleven years now. I am continually amazed at what can be accomplished with just a few PV modules. Don's bus (see story on page 16) is a perfect example of the freedom offered by solar energy. Don can go just about anywhere and he can take his energy source with him. There is no noisy generator, no pollution, and, once the system is paid for, no electric bill. Freedom is what solar energy is best at. The Sun gives us the energy to live where we want, the freedom of new energy delivered daily, and the freedom to will a working ecosphere to our descendents. Who could ask for more?

Richard Perez for the Whole HP Crew



People

Sam Coleman
Steve Crise
Jeff Green
Michael Hackleman
Kathleen Jarschke-Schultze
Stan Krute
Greg Krush
Don Kulha
Mike Lapointe
Sylvia Leutz
Don Lowebug
Harry Martin
Bob Mellin
Karen Perez
Michael Perez
Richard Perez
Shari Prange
Benjamin Root
Bob-O Schultze
Richard Smart
L. A. Wallin
Michael Welch
John Wiles
Myna Wilson

"Think about it..."

"Everything has an end, but a bratwurst has two."

Overheard at this year's
Midwest Renewable Energy
Fair



- **Complete Functional Solar Electric Generators** •
- **Pre-assembled, Pre-tested, Code-compliant Systems** •
- **Standardized Designs for Easy Deployment and Troubleshooting** •
- **Transportable Design for Easy Removal and Redeployment** •
- **Lockable Enclosures to Limit Unauthorized Access** •
- **Optional Back-up Engine Generators with Automated Controls** •
- **10 Year Module Warranty, 2 Year System Warranty (5 Yr. Optional)** •
- **Optional System Performance Data Logger with Remote Phone Access** •
- **Many Models and Sizes for Commercial & Residential Applications** •



We Also Distribute System Components:

Solarex PV Modules, Batteries, Regulators, Trace Inverters, DC Switchgear
Check out our web site: <http://www.solardepot.com>



San Rafael, CA 94903

61 Paul Drive
Phone: 415-499-1333
800-822-4041
Fax: 415-499-0316

Sacramento, CA 95826

8605 Folsom Blvd.
Phone: 916-381-0235
800-321-0101
Fax: 916-381-2603



Qualified Dealer Inquiries Welcome. Hands on Training Seminars for New Dealers

KBYN-FM

Solar ON THE AIR



Don Loweberg

Photos by Silvia Leutz ©1996 Don Loweberg

About 10 years ago Don and Sylvia Leutz, both broadcast professionals, moved from the San Francisco Bay Area to Twain Harte, California, a small, prospering mountain community in the central Sierra Nevada.

They dreamed of owning their own FM radio station. That dream materialized two years later when KKBN went on the air. The station did well in providing a mix of national and local programming. About two years ago, propelled by the success of the station and the growth of the surrounding area, they began planning a sister station. Many factors must be dealt with in establishing a station. One of the most challenging turned out to be finding a transmitter site. It had to give good coverage of the desired customer areas but not interfere with other broadcast frequencies used in the region. The best site for the new station did not have utility power and the cost of providing it was excessive. So began their self education about photovoltaics (PV) as a power source for the new station.

PV communications research

Don researched PV for some time. He talked to local phone company personnel about their cellular repeaters that used PV. He also talked with local residents using PV for home electricity. One person suggested that Don subscribe to Home Power Magazine. Reading Home Power, Don felt well enough informed to begin making contact with various PV companies and solicited bids for his project. That phase ended when Don selected Offline Independent Energy Systems to do the job.



Above: Author Don Loweburg in front of the power center and inverter

Design

The initial design was based on 500 Watts of continuous DC load at 48 Volts. Complex projects like this are often in a state of flux and it developed that a different transmitter would be used requiring 72 Volts DC and with a higher load of 700 Watts. Our initial design included battery chargers with propane generator backup. The new 72 Volt DC requirement meant that more costly chargers would be needed. At this point we rethought the basic approach and shifted

to 120 volts ac using an inverter. One immediate benefit was that the broadcast equipment cost less when "off the shelf" 120 volts ac was the power source. A sinewave inverter was a must and we decided on the Trace SW4048. Though the Trace's 4000 watt output maximum is overkill for this load, the inverter's efficiency peak at 700 watts was perfect. The built in metering, battery charger, genstart function, and three programmable status relays would be useful features for this application.



Above: Owner Don Leutz checks the power systems status on the Trace 4048's control panel.

The winter snowfall in the Sierra Nevada and the 24 hour per day broadcast schedule made it imperative that this system have generator backup. Trackers were also chosen for the extra kwh output, ease of installation, and because we had plenty of space at the site. The sizing of the array was based on standard assumptions for battery charging systems with generator backup.

Installation

Don acted as project coordinator and directed the different phases of the project. On my initial visit to the site I staked out the array locations. Don was able to do the array support work while the concrete and earth work was being done for the broadcast antenna. Don also took responsibility for getting the PV equipment on site. By being personally involved, Don was able to keep his costs down.

KBYN's Power System

Thirty-Six PV modules, Solavolt SV8500, mounted on three Zomeworks Trackers
Wired for 48 Volt, 3060 Watts

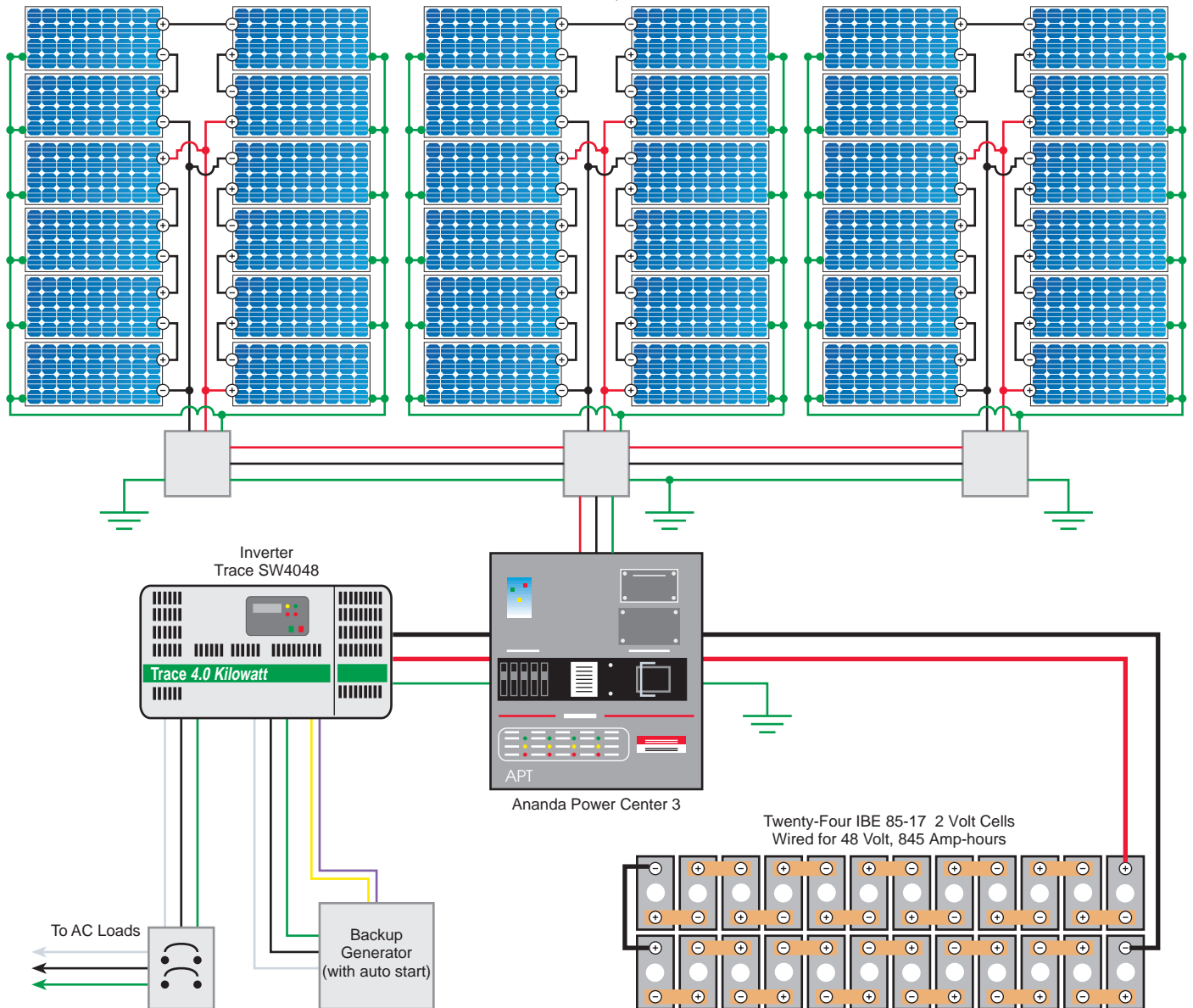

Offline's return on site began with lifting the racks onto the support poles. This was definitely a team effort. The mounting and wiring of the modules went very smoothly and we interconnected the arrays using conduit pre-installed earlier by Don. A junction box mounted on each array support pole serves as array combiner, parallel junction point between arrays, and houses lightning protection for each array. An insulated cargo container provided housing for all equipment. Again, on site work responsibilities were shared. Don took care of ac wiring, ventilation, and generator installation. Offline took care of the PV, power center, battery, and inverter setup.

Testing

Prior to installing the broadcast equipment we did a power test for the array and inverter and also tested the genstart. Everything worked as expected. The broadcast equipment was installed and we powered it up. The actual load came to 766 watts, a bit more than predicted. We had installed an extra pole for another rack of modules anticipating the need to increase power. This will probably happen next spring. At this time the array supplies all transmitter power during summer months. Generator backup begins in mid fall and increases to 3 to 6 hours per day in winter.



Above: KBYN's transmitter.

On air

With 500 watts of RF this is a very efficient station. Because everything is new, the station has state of the art broadcast quality. "Better than most of the big guys out there" states Don. The studio is linked by ISDN phone line to a relay site from whence the programming is sent as a wireless digital signal to the transmitter site. This is a two way link with critical transmitter information sent back to the studio. In the studio Don can monitor station performance, temperature, battery voltage, and start the generator if necessary.

Oh, oh!

About two weeks after initial power up we got a distressed phone call from Don informing us that the station was off the air. In the broadcast industry this is indeed a high adrenaline situation. After a few phone calls to Trace and our supplier, we were able to arrange for next day inverter replacement. In about 24 hours we had the station back on the air. Not bad if we may look for the good in a bad situation. We credit Trace with being able to do the right thing and working with us to get the station back on the air with a minimum of down time. Follow up with Trace's technical support department determined that an output transistor had failed.

There was one later glitch involving the generator start function. As winter approached, the generator needed to run every day for a few hours. The auto genstart function of the Trace failed after a month or so of successful operation. After reset the inverter again successfully started the generator. Following several conversations with Trace's engineering staff it was determined that the problem was with the programmed values in the generator start set up and the inverter's interaction with the genset while warming up. We changed some programming values but continue to have occasional start problems. This is not a major problem since Don can start the generator remotely from the studio. Our understanding is that the next software upgrade by Trace will address these issues.

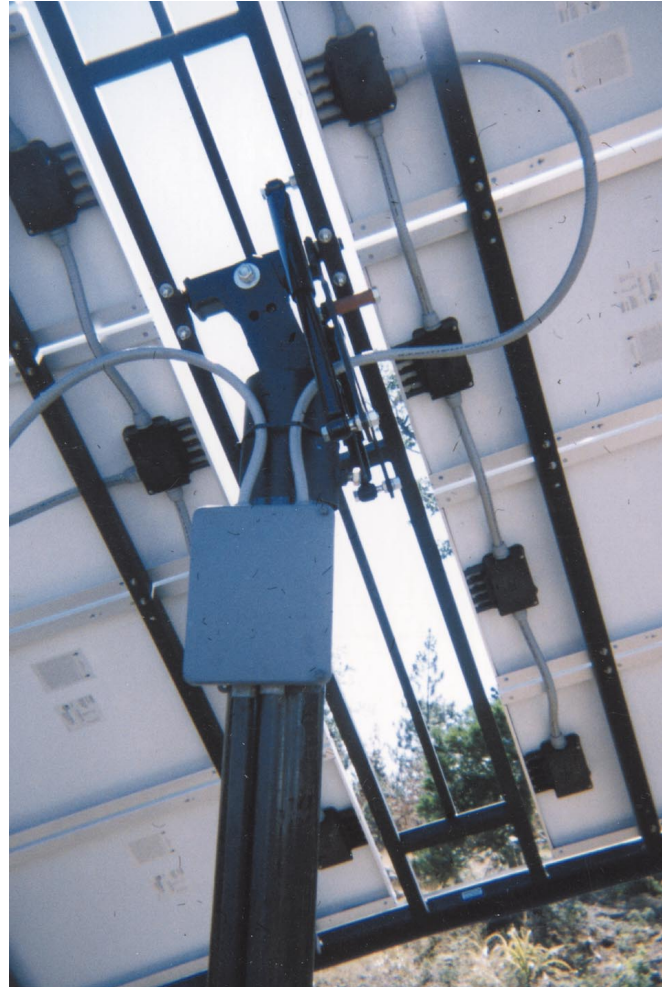

Above: A view of the PV's from beneath the Zomeworks tracker shows the flexible conduit and combiner box.

Below: Sylvia Leutz in front of the three tracked arrays of twelve Solavolt modules each.



Systems

Radio Station PV System Cost

<i>Item</i>	<i>Cost</i>	<i>%</i>
36 Solavolt SV8500 3,060 W peak	\$16,222	46%
IBE L-A Batteries, 845 Ah @ 48 VDC	\$7,200	21%
3 Zomeworks Trackers	\$3,900	11%
Labor	\$3,000	9%
Trace SW 4048 Inverter	\$2,680	8%
APT Power Center 3-48-202	\$1,095	3%
Miscellaneous Electrical	\$900	3%
<i>Total</i>	\$34,997	

This project had it's rough spots, but on the whole it is a success. A critique of the design indicates that the system was sized a bit too small for the actual load. We did have premature and unexpected equipment failure. However, with good manufacturer's support we minimized the down time . It's important that this kind of support be available within the industry. Knowing this we can comfortably expand ac photovoltaic applications to include "mission critical" projects.

Access

Author: Don Lowebug, Offline Independent Energy Systems, PO Box 231, North Fork, CA 93643
209-877-7080 • Internet E-mail: ofln@aol.com



MORNINGSTAR

four color
camera ready

3.5 wide
4.5 high

TROJAN BATTERY CO

camera ready
four color
7.2 wide
4.5 high

TRACE ENGINEERING

camera ready

full page

four color on film

This is page 11

Solar-Powered CATTLE SALOON

L.A. Wallin

©1996 L.A. Wallin



Cattle were first trailed to Montana from Texas in the late 1800's to help feed hungry miners working in the precious minerals boom then in full swing. On the vast open range the critters multiplied into huge herds. With the arrival of railroads from the eastern states and advent of transport refrigeration, both livestock and swinging meat grown in the Big Sky found their way to distant markets.

In the 1950s, REA lines made big inroads into the area bringing electric power to isolated ranches and farms. There are still many ranches with pastures which are as large as counties in many other parts of the nation. Often the cost of installing service at remote livestock water wells makes it uneconomical to consider. Sharp fluctuations in prices received from the sale of animals has continued to stab into the pocket books of ranchers.

Runoff from snow melt and rainfall gets channeled into dugouts on some spreads. There are some artesian wells which flow on their own, thus avoiding use of power for pumping. Very high winds can often turn water pumping windmills into heaps of scrap metal if not carefully maintained. On many ranches cattle are rotated from winter pasture to summer pasture. Alkaline water damages submersible pumps which stand unused for long periods of time. Jack pumps hooked to sucker rod-driven cylinders are viable options. Petrol-fueled engines are often unreliable and are a bigger pain than saddle sores.

Rancher Don Golder, whose place is northeast of Billings, put together a portable outfit to use year around for pumping fresh drinking water for his grass

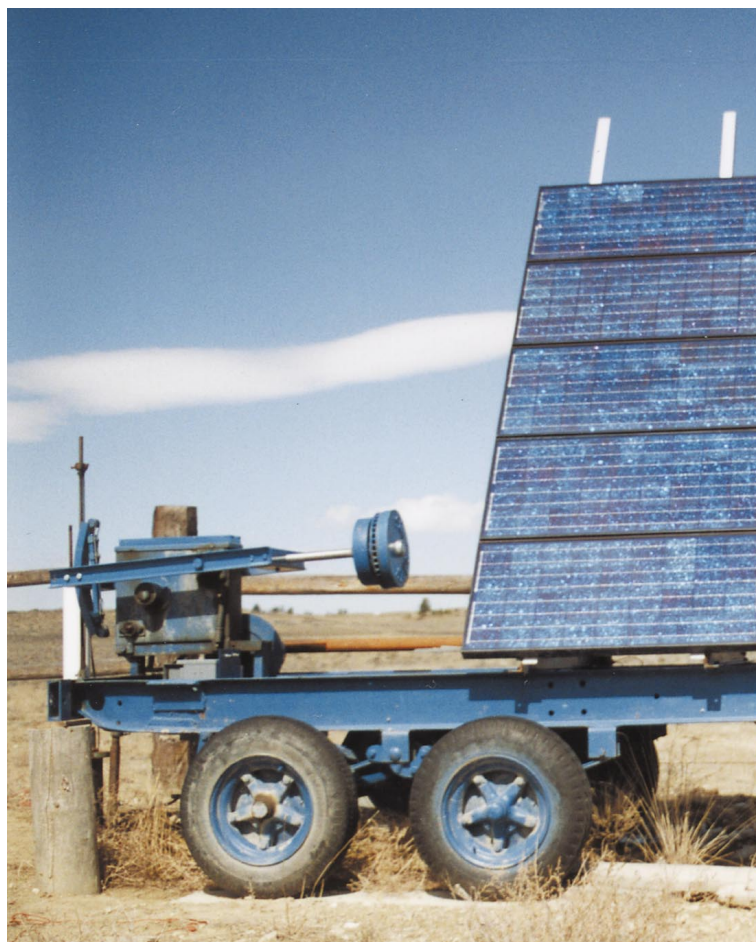

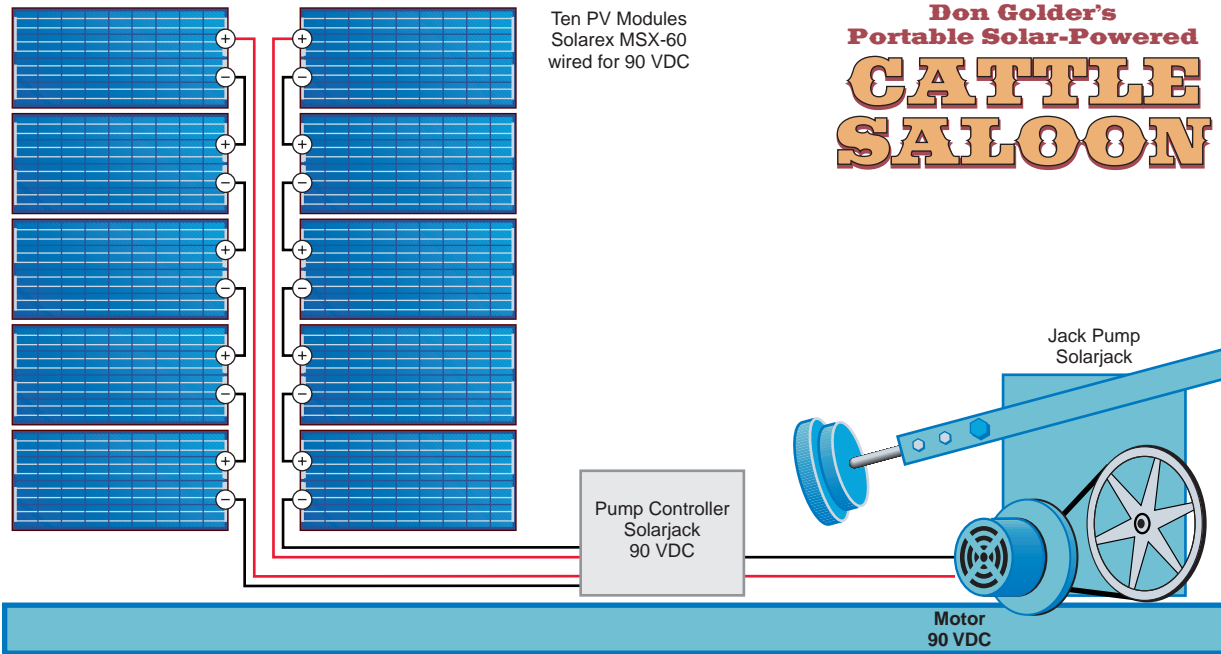

Below: Don Golder's portable PV-powered jack pump provides water for cattle from two different wells, each over 400 feet deep.

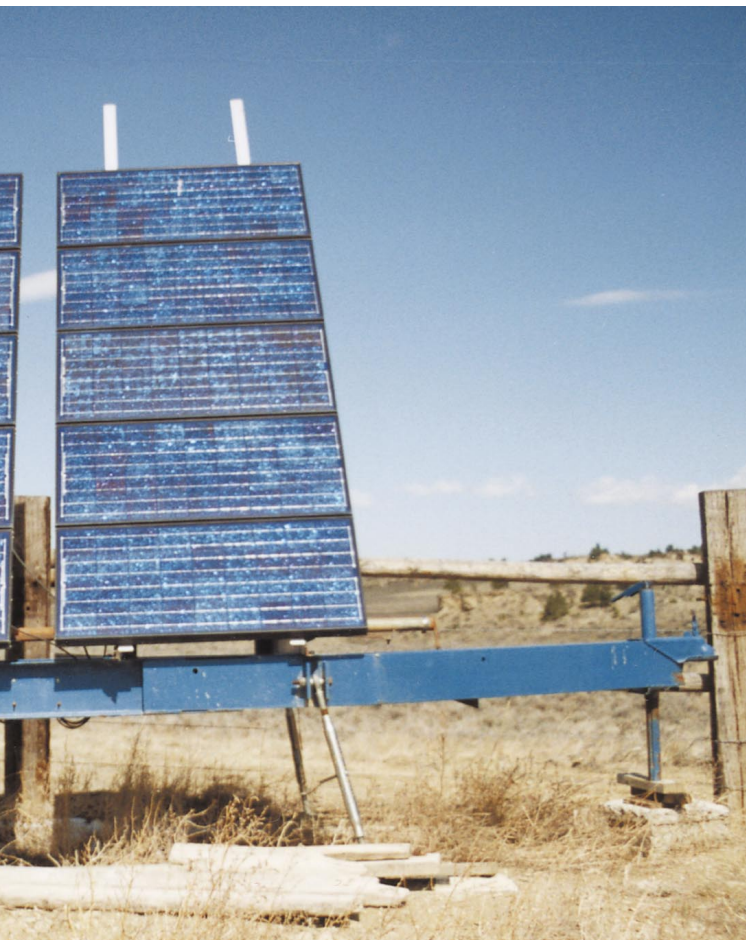

fed cattle. He erected a stationary module mounting rack onto the frame of an abandoned house trailer. Don's quiet generator uses Solarex modules wired in two series/parallel arrays. After passing through a controller the current powers a DC motor which turns a Solarjack pump jack. The unit is used at two separate locations during all kinds of weather. Heavy turnbuckles latch the trailer firmly in place. Each water well is fenced to keep cattle at a safe distance.

The controller on the DC system allows it to operate at reduced but viable water production even on cloudy days. The system is sized so that the cylinder should never have to run dry. Working with his local well driller, Don decided to leave a submersible pump previously powered by a gasoline generator in place below the new pump cylinder. Harnesses were built to keep sucker rods from tangling with pump wires. Since the trailer-mounted modules were put on line, only a few rare occasions have necessitated bringing back the gas belching monster.

Solar hardware was purchased through Tom Bishop at Sunelco in Hamilton, Montana. Don figures that the unit has more than paid for itself. At current prices it could be replicated for about \$11,000, compared to over twice that for bringing in public power lines to each of the wells. Mighty fine looking on a balance sheet.

400 Feet

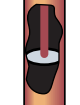

Water Pumping



Above: Detail of the jack pump assembly and the 90 Volt DC motor.

Water is brought up from about 400 feet through a pit less adaptor and stored in underground cisterns. Gravity carries the water to the cattle bar via a float valve. At his winter pastures on the windswept high plains, when temperatures are expected to drop below nothing, Don adjusts the float valve so that a small

stream trickles all night, exiting through an overflow tube to the coulee below. No expensive stock tank heaters are used.

It's many miles of hard riding in unbelievable chill factors from the main ranch house to either well. The winter range normally has plenty of grazing and shelter for cattle. With ground heat stored in the massive concrete cisterns and trough, seldom does Don have to chop ice for livestock. Critters need water even in cold weather. They do much better when their drinking water is reasonably warm.

The quiet power station has held up very well under adverse conditions, including twice yearly commutes over rough stock trails.

Access

Author: L.A. Wallin and her husband live in an earth bermed, rock and turf roofed, solar electric-powered log home. They lived in a tent for three years while building their present structure. Not fancy, but it's theirs.

Country hard-scrabble raised, during the past fifteen years they have developed many alternate methods of surviving tough times.

Box 356 Roundup, MT 59072 • 406-575-4395



Can this small PV system lift this much water from 500 feet down?

These pictures tell the story!

Introducing

SunRise™

Submersible Pump
by Fluxinos

4 GPM at 150 Feet

2 GPM at 350 Feet

1 GPM at 600 Feet

with a 300 watt array!

Exclusive USA Importer:

Dankoff Solar Products, Inc
(505) 820-6611 fax (505) 820-3160
sunrise@danksolar.com

Dealers & Distributors Invited!



ANANDA POWER TECHNOLOGIES

four color on film negatives

full page

This is page 15

Don's Rolling, PV-Powered, Computer Laboratory...



...& Coffee House

Richard Perez and Don Kulha

Don's 1969 Volkswagen bus reminds me of Tom Swift's flying lab, only better. Don is a high-tech kinda guy, he's worked on everything from NASA's AXAF space telescope project to mastering Home Power's renewable energy on CD-ROM projects. Much of Don's work involves computers and he sees no reason why leaving home should interrupt the flow of data....

Why a solar electric system on a VW bus?

When Don's last job, the telescope mirror project ended, he decided it was time to hit the road for a while. Two of his major missions were a search for an independent country homestead and completion of the Solar2 CD-ROM. Don figured that he'd use many of the solar electric components in his new homestead. Meanwhile, the PV system could provide power on the road and at HP Central on Agate Flat for CD-ROM production.

This system is flat out amazing. I have never seen such a large system attached to such a small vehicle. Don's power requirements for computers, lighting and cooking far exceeded the energy produced by a couple of PV modules. We're talking big time energy usage that rolls down the road. When Don first told me about his system I was skeptical. I knew he could mount all this stuff on a bus, but I wasn't sure it would survive. After 2,000 miles on the road and four trips up the impossibly rough roads to HP Central, I'm convinced.

Here's a direct quote from Don on why he made his rolling solar power station.

"A few things combined to bring about solar on the van. Foremost I wanted to do it. It's convenient having a portable source of clean, dependable and quiet power. Previously I'd used a small 200 watt Powerstar inverter, the vehicle battery and an oversized 50 amp Bosch alternator. While this worked fine for running my laptop, Deskjet printer and a couple lights, after 5-6 hours I needed to recharge. That meant running the engine about an hour before the battery got back to even. That was such an inefficient and obnoxious way get a few hundred watts it didn't happen often. I feel much better about the power I'm using now."

"Another reason was education. I've learned a lot from building and using the system but its biggest impact is on people that see it and learn how it works. I've found that a lot of folks like the idea of using solar energy and understand it conceptually but getting close to a working system makes it real for them. Many of them have never noticed a solar cell besides the one on their calculator. Now here's one that can run computers, a TV, a microwave and lights. Most go away with a new appreciation for solar and more importantly now think of it as something that works, something they can do."

Energy Use

Don's primary energy needs are computers, lighting, communications, and cooking in the microwave oven. The various appliances are detailed in the table shown here. Note that the energy consumed is about 1,400 Watt-hours per day. This is enough energy to run an efficient country homestead. So far Don reports no problem running any of this equipment from inverter-produced 120 vac electricity. Don says that the motorized loads (like the coffee grinder and a drill) work

Don Kulha's Loads

Item	watts	Hrs /day	w-hrs /day
486 Computer w/ 15" Color CRT Monitor	170	3.00	510
2-15w Compact Fluorescent Lights	36	6.00	216
486 AST Color Notebook Computer	32	6.00	192
Sharp Carousel 600w Microwave Oven	1030	0.10	103
2 Meter Ham Radio / Scanner / Cell Phone	24	4.00	96
HP Deskjet 660CSE Printer	11	4.00	44
Coffee Grinder	180	0.05	9
Inverter & Battery Inefficiency			234
		Total	1404



Above: Don, at his computer system, can work on the upcoming Home Power CD-ROM while camping anywhere he wants.

better on his sine wave inverter and that his compact fluorescent lights don't buzz like they did on modified sine wave inverter power. Don's communications equipment (2 meter ham transceiver, a CB radio, and a cellular telephone) are all powered by 12 VDC directly from the system's battery. Other than the communications gear, all other loads are powered by the inverter.

Energy Production

Don uses five Siemens PC4JF photovoltaic modules to produce his electrical power. The array is wired to provide 24 Amperes of current at around 14.5 VDC. In terms of power the array produces around 375 Watts. In terms of energy, the array makes about 2,000 Watt-hours per day.

Don and his friend Joe Peterson built the PV mounting rack from 1 inch by .060 inch wall mild steel square tubing. All the joints were welded. The rack needs to be sealed from moisture otherwise it will rust from the inside out. Don is adding rubber washers between the PV modules and the mounting rack. The rubber washers will keep water out and prevent noise from vibration on rough roads. Small stainless steel aerodynamic spoilers on the front of the rack help eliminate lift and vibration. All of the hardware used on this rack was stainless steel

except for the critical mounting bolts which are grade 8 steel for strength and some self locking nuts.

Energy Processing

This system uses three pieces of energy processing hardware. First is the 1,000 watt Exeltech inverter which converts 12 VDC into 120 vac, 60 Hz. power. Second is the Trace C30A which regulates PV power production and prevents overcharging the battery. The third energy processor is a Cruising Equipment E-Meter which provides detailed information about the battery's state of charge and system performance. Here's are Don's comments on this energy processing hardware.



Above: Don's van produces enough solar electricity to run an efficient homestead and has no trouble powering a tent full of computers.

"The Exeltech inverter is wonderful. I bought it on the strong recommendation of friends and thought I was being kind of extravagant at the time. Now that I see how it handles my loads and how much happier they seem to be on sine wave power I know it was a good move. Friend Tim Porritt helped install it and after confirming voltage and frequency gave it his ultimate test bringing out some vintage audio gear. His expert ear pronounced the Exeltech very clean and stable. I could have gotten by with a 500 watt but the 1 kW Exeltech lets me run the microwave in the van. Just the thing for a mug of fresh ground and brewed French roast coffee."

"I'd like to upgrade from my Trace C30A to their new C40. The C30A works fine but a PWM controller is going to get my batteries filled earlier in the day and be quieter in the bargain. I don't want to bet on the afternoon sky staying clear."

"I love the E-Meter. Watching it has taught me a lot about system performance, the characteristics of my loads and energy use patterns. The rolling display setting where it cycles through its various readouts is very handy. I'll admit to wasting a couple of watts by not letting the display automatically dim itself. I like watching it and knowing what's going on at any given time without having to walk over and press buttons."



Above: A reinforced battery box holds the two 6 Volt, 350 Ah batteries.

Right: A view towards the front of the bus showing a computer workstation and RE control center.



Don's Rolling..Coffee House

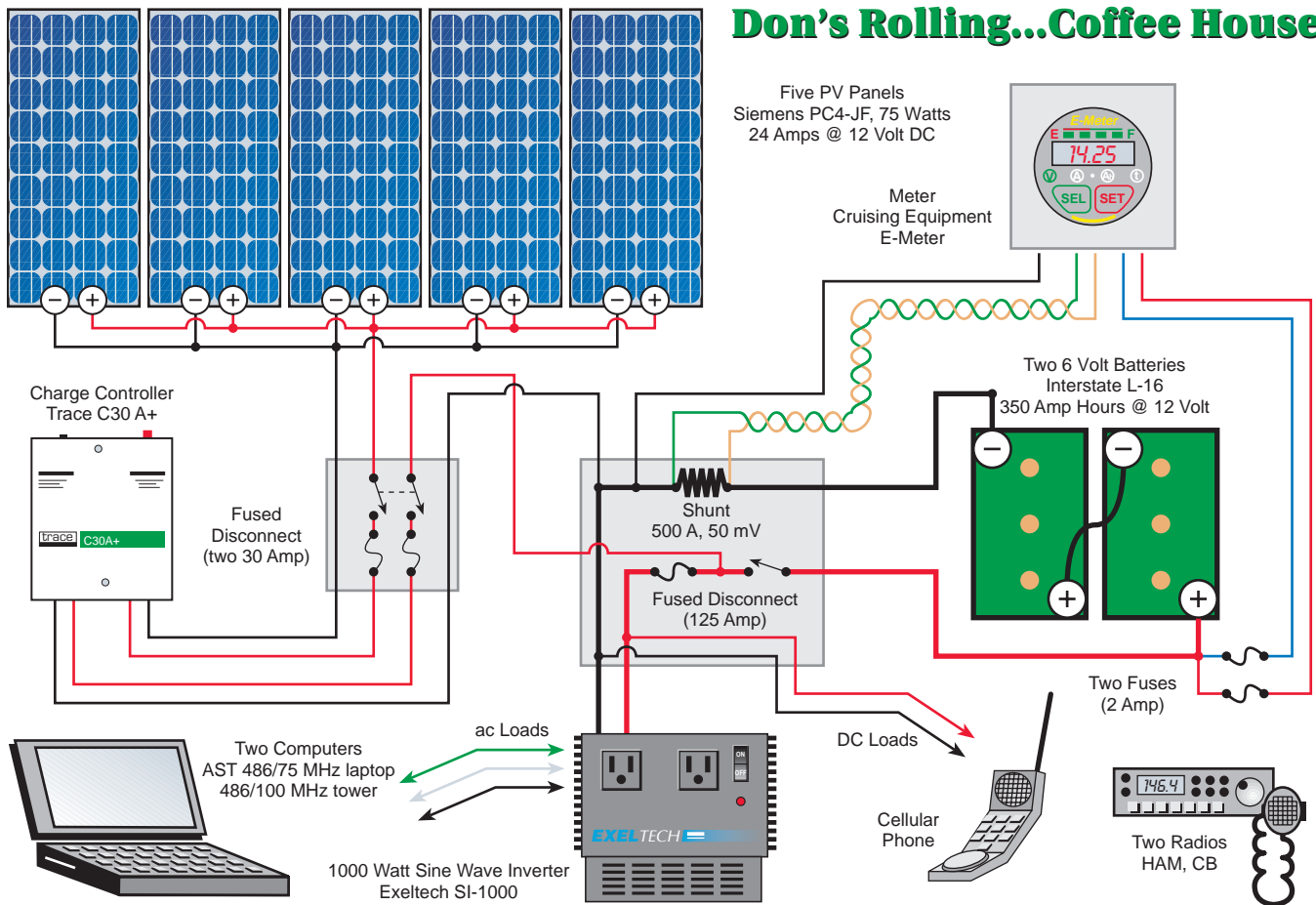

Energy Storage

The solar electric system in Don's bus uses two Interstate L-16 lead-acid batteries for energy storage. Each six Volt battery has a capacity of 350 Ampere-hours. Don wired the two batteries in series to get 350 Ampere-hours at 12 Volts DC. This battery provides about three days of stored energy for the system. Don

Don Kulha's PV System Cost

Item	Cost	%
5 - Siemens PC4JF 75w Panels	\$2,200	50%
Exeltech SI 1000 Inverter	\$1,150	26%
2 - Interstate L-16 Batteries	\$330	7%
Cruising E-Meter w/Shunt	\$200	5%
Roof Rack/Material & Labor	\$140	3%
Conduit, Fittings, Wire, Boxes	\$130	3%
Trace C-30A Controller	\$90	2%
Disconnects & Fusing	\$88	2%
Miscellaneous Material	\$50	1%
Fasteners/Grade 8 & Stainless	\$43	1%
Total	\$4,421	

built a wooden box to house and secure the batteries which weigh about 240 pounds. The box has steel corner braces, large butterfly clamps holding the lid and 7/16 bolts securing it to a metal bulkhead. It is very important to secure batteries in mobile solar electric systems. Think about having the heavy batteries (and the 18 quarts of sulfuric acid they contain) jump in the front seat with you during an accident.

Driving the bus

Don figures that the entire PV system added about 400 pounds to the weight of the bus. This includes the battery box and ancillary equipment like disconnects, wiring, and NEMA boxes. The system could actually use twice the battery capacity it now has, but the bus will support no more weight. Don's gas mileage dropped about 15% due to the additional weight and wind resistance. The bus was retrofitted with front disc brakes and oversized rear drum brakes to stop the added weight of the system. Don also beefed up the suspension by adding gas shocks and heavy-duty 6-ply Michelin LTX tires. The handling of the bus actually improved because most of the added weight (batteries) went up front.



Above: Detail of the custom-welded tilt-up rack and its five Siemens PC4-JF photovoltaic modules. Note the flexible conduit between the modules.



Above: A close-up view of the non-metallic flexible conduit and the bulkhead fitting into the bus.

Don and his bus meet the public

One of the great things about Don's bus is public relations. Folks love it. Here is how it goes in Don's own words.

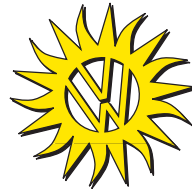

"People will walk past the van parked on the street, stop cold and turn around to stare at the panels. If they stop to ask questions the conversation will often turn to the cabin or RV they've thought about outfitting with PVs."

Once while parked in the lot of a large hardware store, a guy had asked me about the panels and I'd tilted them up so he could get a better look. Shortly I was surrounded by about a dozen curious folks and you could see others making a beeline across the parking lot towards us. They thought it was one of the manufacturer's demos the store often runs. I put the panels down quickly but it still took an hour to get out of there. I get the sense that solar electricity is one of the best kept secrets. Many folks are intensely curious about it. We need more applications of solar power out in plain sight, doing real-world stuff, for folks to learn that it's possible.

I'm going to put together a simple hand-out describing how the system works, what the bits and pieces are, plus where to get them and more info. This is too good an opportunity to pass up."

Access

Don Kulha, PO Box 7518, Santa Rosa, CA 95407 •
Internet e-mail: dkulha@wco.com

Special thanks to Bob-O Schultze, Ken Munc at Vintage Tech VW and Craig Wells at Interstate Battery.



Above: Don's rear bumper sports a badge of his commitment to renewables and a message of encouragement to the rest of us.



SOUTHWEST WINDPOWER

camera ready, four color, on negative

7.125 wide
4.5 high

Join us and get your hands-on *Learn the practical use of solar, wind & water power.*

Hands-on Workshops **NATIONWIDE**

CARBONDALE, CO

- PV Design & Installation August 5 – 16
- Advanced Photovoltaics August 19 – 30
- Solar Home Design September 16 – 27
- Env. Bld. Tech.

Strawbale, Adobe, Cob Weekends – September
WOODSTOCK, NY

- PV Design & Installation October 14 – 19
- Wind Power October 21 – 26

TUSCON, AZ

- PV Design & Installation November 4 – 9

Call for a complete schedule.

Solar Energy International

Renewable Energy Education and Sustainable Development

BOX 715, CARBONDALE, COLORADO 81623

(970) 963-8855 • FAX (970) 963-8866

e-mail: sei@solarenergy.org

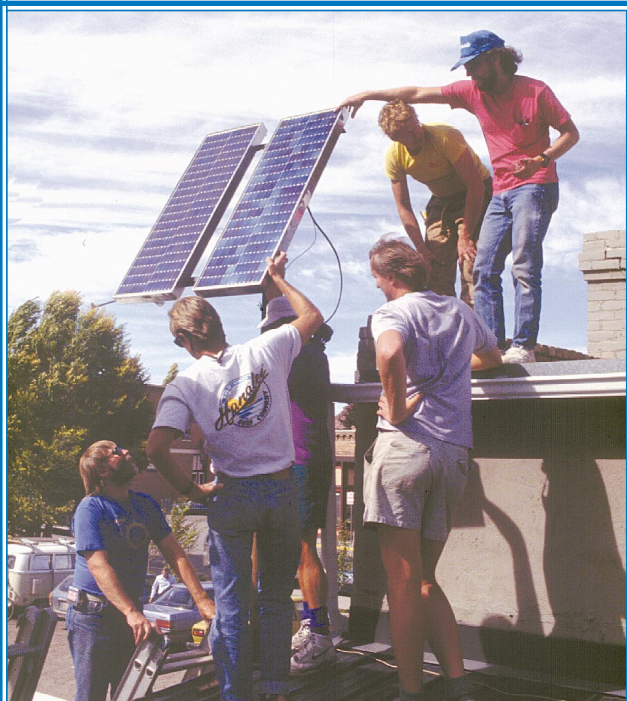

You Can Do It!



Greg Krush

©1996 Greg Krush

Above: The author enjoys the front porch of his 12 Volt DC-powered home in Colorado.

This article is written to let people know how simple and inexpensive it is to install a photovoltaic (PV) system. Although I've been interested in alternative energy for some time, I had only examined two other PV systems before I installed mine. Most of my knowledge came from *Home Power Magazine*.

In July 1993, I purchased 160 acres along with an abandoned homestead. The house is 24 by 24 feet with two stories and a full basement and had not been lived in for forty years. There was a well with a windmill pump. The house had never been wired or plumbed and needed to be totally redone with a new roof, windows, plaster, and fixtures. I never considered REA as the cost would have been \$18,000 to bring in power 1 1/2 miles. The total cost of my system was \$3,691.

I haven't included costs for wiring and plumbing in the house in my system's cost figures as this had to be done regardless of my power source. The only extra costs for deciding on an AE system was using a heavier gauge wire for 12 Volts, using 3/4 inch diameter pipe for the low pressure water system, and the purchase of a propane refrigerator.

Electric system

I started with four sets of ARCO quad lams that I mounted on a homemade wooden frame, adjustable for the seasons. I didn't consider the use of a tracker because of the high winds along the front range and my desire to keep things simple. The quad lams will produce 15 Amps consistently and 30 Amps in full sun. Each panel is connected in series to form sets of four then wired in parallel and connected to 2/0 cable that runs to a Backwoods Solar Electric PV controller. I found a dozen thirty year old, two volt, deep cycle lead acid batteries at a local battery recycling center. Two series of six batteries provide 640 Amp-hours of storage at 12 Volts.

I wanted to keep the batteries out of the house, so they are located in an insulated outbuilding near the windmill. This building also houses my water storage tank and doubles as a greenhouse to start plants in the spring.

Power runs from the outbuilding through a 2/0 cable to a 60 Amp main fuse. In the house I have ten auto type fuse holders mounted in a standard electric box that are connected to individual house circuits. All house circuitry is 12 Volts with compact fluorescents for most lighting. I also use some halogen bulbs.

I have a 100 watt inverter connected to a wall switch to power the stereo, CD player, and tape player. Another 150 watt inverter powers the sewing machine, TV,

Greg Krush's PV System

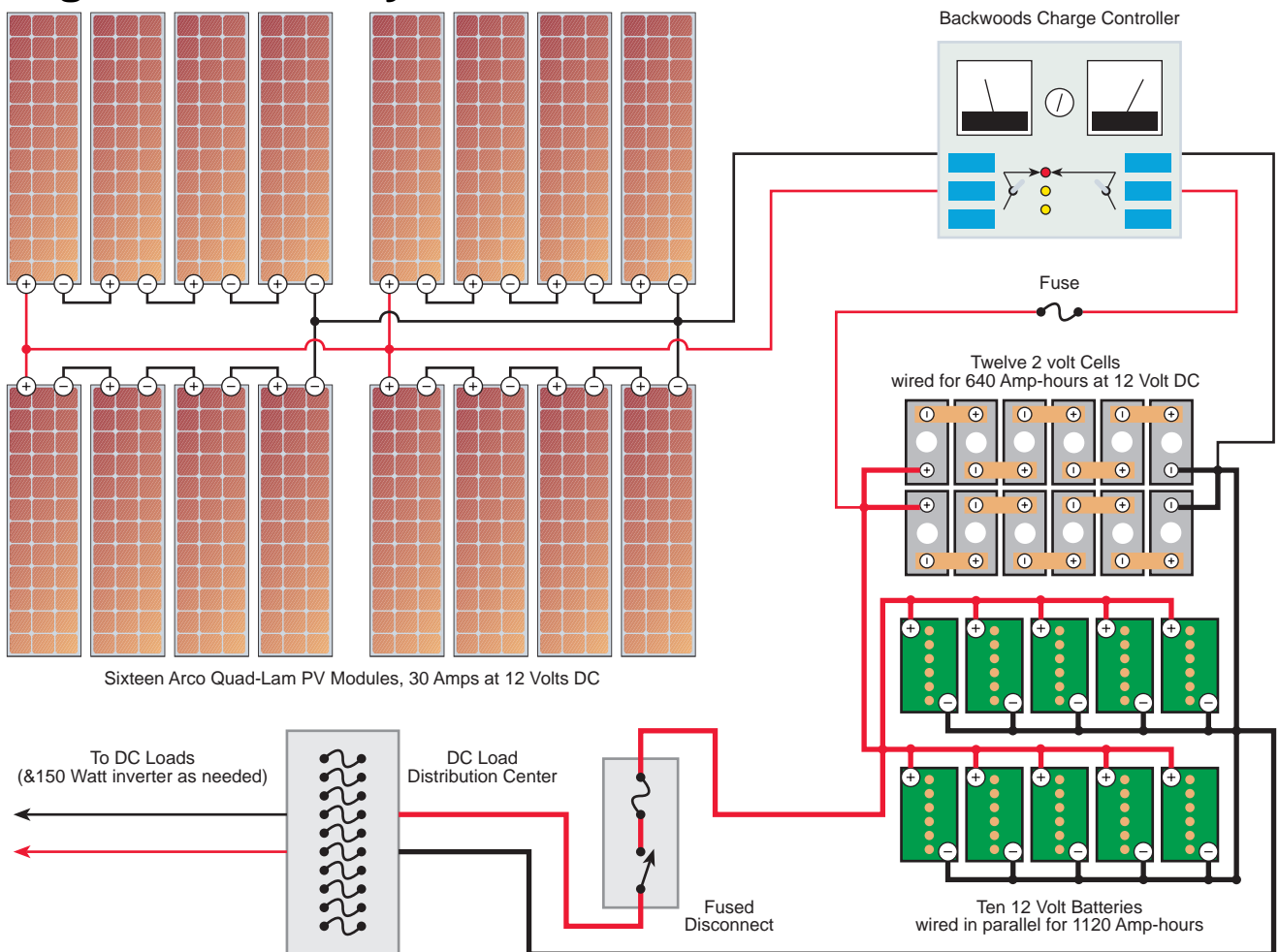

computer, printer, and charger for my cordless drill. This inverter is moved around the house as needed. I use a Phonemate answering machine. I bypassed the transformer and connected it directly to the 12 Volt wall circuit.

My biggest electrical load is the freezer, where I store meat and garden produce. I installed a NovaKool freezer unit into an old 14 cubic foot chest freezer and lined it with four inches of insulating blue board. This reduced the interior capacity to about 6.7 cubic feet. It has worked great although it does run a lot during hot spells. When I added the freezer to the system I added ten Trojan 112 Ah batteries giving me 1760 Ah total. I couldn't find any more good used batteries so I purchased these new. I also run three water pumps on 12 Volts.

Water

My water is pumped from the 100 ft well by the windmill. The water flows by gravity to the outbuilding where it goes into a 400 gallon storage tank. Overflow

runs out the other side of the outbuilding to a 1000 gallon storage tank used in summer to water plants. Further overflow runs on the garden. From the 400 gallon tank the water is piped underground to two places, a Mirafount energy-free waterer for the cattle and to a pump in the basement of the house.

From the basement the water is pumped by a 12 Volt Flowjet to two fifty five gallon plastic barrels in the attic equipped with a float switch. Water flows from there to the house system. The system's 3/4 inch pipes provide plenty of volume. Grey water is plumbed to drain to the flower gardens adjacent to the house. The toilet is connected to a septic tank with a leach field.

I also have another Flowjet pump that I attach to the 1000 gallon tank in the summer to water trees and shrubs I've planted around the homestead.

Hot water

My hot water system consists of three parabolic concentrator panels mounted on the roof. I bought 10 old panels at an auction and combined them to make

Systems



Left:
Greg's PV array,
battery shed /
greenhouse,
water storage
and wind
pumper.



Right: NovaKool
unit & extra
insulation
installed in an
old chest freezer.

three good ones. I run antifreeze through these panels and up into a copper loop that I soldered into a 120 gallon steel tank. The system was slow to start thermosyphoning because I only had a 12 inch rise from the collectors to the tank. To solve this problem I installed a 12 Volt circulating pump and a thermostat. This system has provided all my hot water during spring summer and fall. During the winter months when the days are short I use a backup system through a propane heater to ensure a hot shower. During this time the solar system will preheat the water to at least 80°.

Other Power Needs

Currently I use the gasoline generator to run the wringer washer, power tools, and the welder. I intend to convert the washing machine to 12 Volts. I would also like to put in a wind generator to power the shop.

Conclusion

I had very little experience with PVs before I started this project. It has run flawlessly except for two 2 volt cells going bad, which isn't bad for 30 year old cells, and a bad relay on the controller which was replaced by

Greg Krush's PV System Cost

<i>Item</i>	<i>Cost</i>	<i>%</i>
4 Sets used ARCO Quadlams	\$1,021	27.7%
Freezer Nova Kool, insulation	\$734	19.9%
Batteries: new Trojans	\$688	18.6%
Batteries: used 2 V cells	\$380	10.3%
12 V Lights	\$300	8.1%
Backwoods PV controller	\$297	8.0%
Inverters	\$186	5.0%
2/0 Cable	\$45	1.2%
Mounts, lumber, hardware	\$30	0.8%
Fuses and switch boxes, used	\$10	0.3%
<i>Total</i>	\$3,691	

Greg Krush's Domestic Water System Cost

<i>Item</i>	<i>Cost</i>	<i>%</i>
Repairs to windmill	\$389	45%
2 Flowjet pumps	\$193	23%
1000 gallon storage tank	\$125	15%
400 gallon storage tank	\$100	12%
Miscellaneous valves and pipe	\$50	6%
2 @ 55 gallon barrels	\$0	0%
<i>Total</i>	\$857	

Greg Krush's Hot Water System Cost

<i>Item</i>	<i>Cost</i>	<i>%</i>
Hartel circulating pump	\$112	36%
Collector panels, used	\$100	33%
Hose	\$30	10%
Insulation	\$25	8%
Thermostat	\$20	7%
Antifreeze	\$20	7%
Storage tank	\$0	0%
<i>Total</i>	\$307	

Backwoods Solar. I've never had to charge the batteries with the generator.

Since September of 1993, my system has provided all the power needed for my home at a very low cost. If you have further questions please feel free to contact me.

Access

Author: Greg Krush, 10450 Weld Co. Rd. Nunn, CO 80648 • 970-897-2281



We sell them all...

Because we've flown them all!

Write or call for the world's best prices on...

- BWC 850
- BWC 1500
- 10 kW Excel from Bergey Windpower Co.
- Wind Baron 750 from Wind Baron
- Rutland Windcharger from Marlec Engineering
- Jacobs 29-20 from Wind Turbine Industries
- Whisper 500 & 600, 1000 & 1500, 3000 & 4500 from World Power Technologies
- Windseeker 500 & "AIR" from Southwest Windpower
- Towers for Wind Generators
- Tilt-up tower kits

SPECIALIZING IN WIND/PV HYBRID SYSTEMS & DESIGN



LAKE MICHIGAN WIND & SUN

3971 E. Bluebird Rd.,
Forestville, WI 54213
414-837-2267

FAX 414-837-7523

"Wind generators & parts made with wind-generated electricity"

Solar Electric Systems

From a Company Powered by Solar!



124 pages of Answers...

Our publication begins with basic load analysis and sizing information and includes case histories, design guidelines and useful in depth data required for system layout. It offers detailed descriptions of solar components and packages, paying little attention to consumer products. A must for every energy library.



Our shop utilizes its own 2.5 kw array and 35 kw battery bank for daily power needs and testing of new products.

Whether you are looking for one module or a 90-module state of the art, turn key system — Sunelco can be of help.

Sunelco puts the customer first. We offer fast service, factory trained technicians, personal assistance and answers to your questions.

Our large inventory and factory direct distributorships allow us to provide our customers with good pricing and excellent service. We stand behind the products we sell!

- Comprehensive selection of solar and system related components
- Experienced, professional technical assistance
- Support unsurpassed in the solar industry
- Largest inventory and the fastest shipping department in the industry allows shipping in 24 hours if not the same day.

For the home owner who is working with an Architect or Contractor, we can work directly with your technical people. As well, our installation crew can handle the complete job, just like your plumber or roofer.



P.O. Box 1499HP • Hamilton, MT 59840

order line 1-800-338-6844

technical assistance line 1-406-363-6924

GYROKITE

camera ready
b&w
4.5 wide
2.4 high

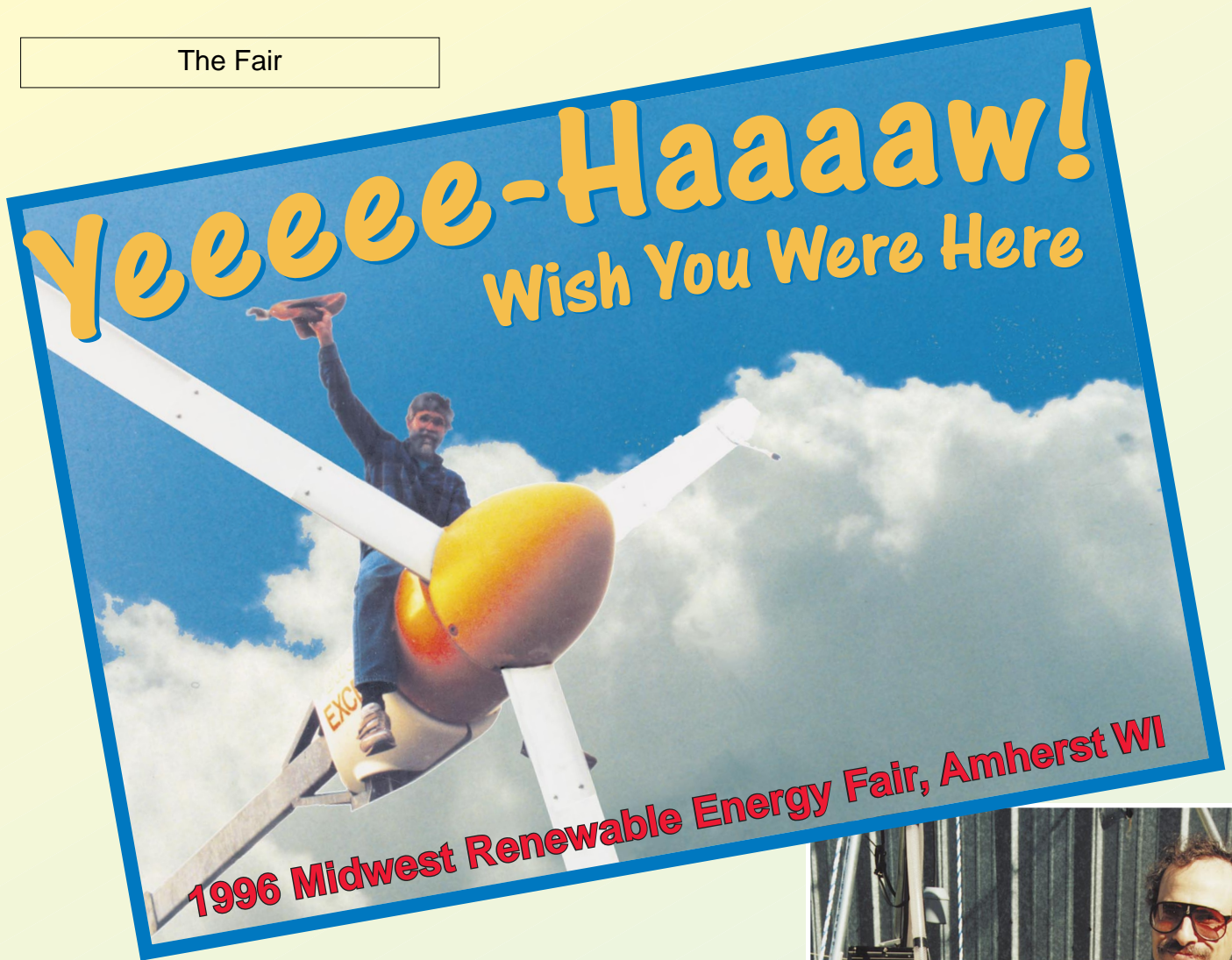

WOW! This seventh annual fair was the best yet. The biggest renewable energy event in the known universe offered 86 different workshops, 80 exhibitors, food, music, and fun! 9,300 people attended from all over the midwest and the world.

Here is Home Power's Photo Album; (this is the closest we get to a vacation). We hope to see even more of you there next year. Don't miss it!

A chance to meet with those in the know: Steve Willey of Backwoods Solar talks biz while Elizabeth smiles out of focus.



New product debuts abound: Windy Dankoff says "see the gauge" on his new PV-powered, deep well, submersible pump.



Everything solar: Even the workshop schedule was mounted on a huge sun dial in the center of the fair grounds.



Paradigm shift: Paul Collard of Midway Labs (and son Aaron) explain the advantages of concentrator photovoltaics.



Art: Vladimir Nekola's PV-powered fountains are fun, beautiful, and one of a kind.



Only some of the many exhibitor tents in the foreground. Workshop tents can be seen through the trees and EVs at the upper right.



Do it yourself: James Machacek sells plans and custom manifolds so you can build these simple thermosyphon water heaters.

Variety: Exhibitors covering every aspect of renewable energy and energy efficiency showed their wares at the fair.



Answers: Dave Calley of Southwest Windpower discusses the engineering of the Air 303.



Low Tech: Water pumps are still a viable solution says LoTec Windmill Service



Tower of power: A grid intertied 12.5 KW Jacobs wind generator on an 80 foot tower was erected by workshop participants and helped provide power for the fair.

Getting Together: Cooperation is what it takes for the Lake Michigan Wind & Sun crew to stake a claim to an exhibition space.

High Tech: Chuck Bennett of Vanner and Joe Bobier of Sun Selector can boggle your mind with the new communications features on their power center and sine wave inverter.



Whozat?: Small Bear looks even smaller from the top of the wind tower.



Goin' to the Fair: In Amherst even the highway rest areas provide recycling. The parking barricade is recycled plastic. Here Here!



The crowd goes wild: The kid's had a blast. We grown-ups are looking forward to our own category next year.



There Off: Carol Welling and Kurt Nelson act as race officials for the kid's Solar Sprint competition.

The Scoop: Chris LaForge of Great Northern Solar answers questions in the model home.



A question of fuel: Exhibitors educate us to options for home grown heat.

Solar ice cream:
Lots of activities were provided for the kids.



Model home: A whole house was built on site to show the integration of multiple systems in an energy efficient dream home.



Vehicles



No Sweat: Bob Turner shows off his hybrid human / electric trike. Look for a detailed article coming to *Home Power* in the near future.

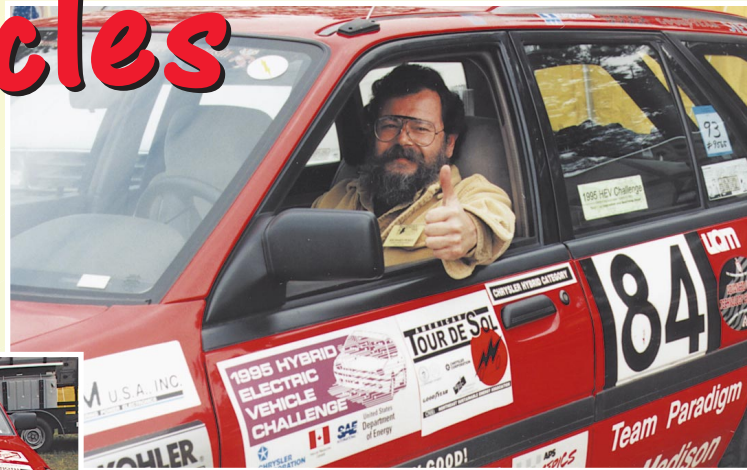

Not Mario Andretti: Richard Perez checks out the University of Wisconsin's Hybrid electric, winner of the 1996 Tour De Sol in the Hybrid class.



The Lowdown: Michael Ryan, a research engineer at the UW gives Richard Perez the technical details on this hybrid race machine.



Utopia!: Michael Hackleman test drives Jim and Claire Kerbel's electric Geo Metro and proves how well EV's fit in to the American dream.



Education

The batts: eight of the sixteen 220 amp hour batteries in Sun Chaser's hold.



Portable power: Sun Chaser's power control center, with 3.2 kW sine wave inverter and computer interface.

Sun Chaser: The Midwest Renewable Energy Association's newest project will provide power for special events while educating the public about renewable energy.





The Fair

Us and Our's: The home power crew and friends. It just keeps getting better!

People



Keynote Speaker: Wisconsin State Representative Spencer Black was Saturday's keynote speaker.



Environmental Excellence Award: Phyllis Peri receives an award for the Wisconsin Center for Environmental Education.



Renewable Energy Promotion Excellence Award: Goes to Don Wichert of the Wisconsin Energy Bureau.

We couldn't get MREFCo-Executive Directors Susan Stein and Terhi Parker to hold still long enough for photos; they were so busy making everything run smoothly. Special thanks to them and all the many others who made this event such a great success!

Access

The Midwest Renewable Energy Fair, P.O. Box 249, Amherst, WI 54406 • 715-824-5166



A Winner: Aaron Collard points to the roof of the model home where lies the 83 Watt BP photovoltaic module that he won in a drawing from Alternative Energy Engineering.



Web Master: Michael Welch helped man the Home Power booth and fielded all the high tech internet questions.

The good 'ol days?: Nah, Richard Perez and Richard Komp discuss the future of renewable energy.

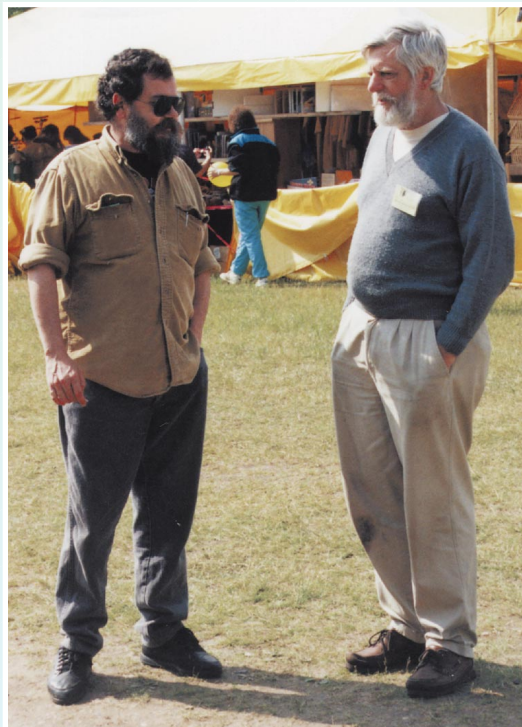

No Power? No Problem!

From System Design to Installation...
Renewable Energy systems for your home, RV, and lifestyle.
Electron Connection - Call Toll Free 1-800-945-7587
Photovoltaics • Microhydro • Windpower • Water Pumping
Consultation • Site Survey • Installations
CA Electrical Lic #613554



Authorized Distributor

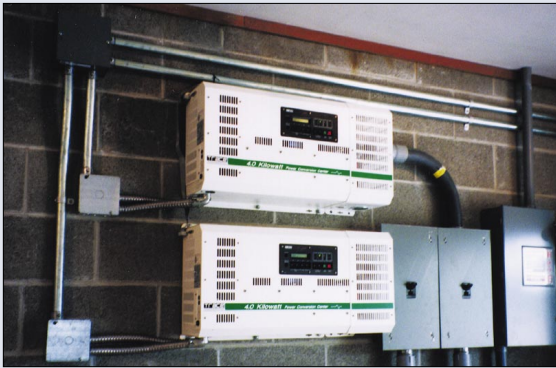

Trace 4,000 watt Sinewave Inverter
Equally at home on or off the grid!
Utility intertie and battery — the best of both worlds!
Sophisticated, high output battery charger
Clean and quiet sinewave power
Over 90% efficiency and low idle power
Now available optimized for alkaline batteries.



Sun Spot™ Solar Oven
* Lightweight — 1¼ pounds!
* Portable — Backpackable!
* Expandable cooking chamber!
* Heats to 350°F!

\$30 shipped free in USA

CA Residents please add 7.25% tax.

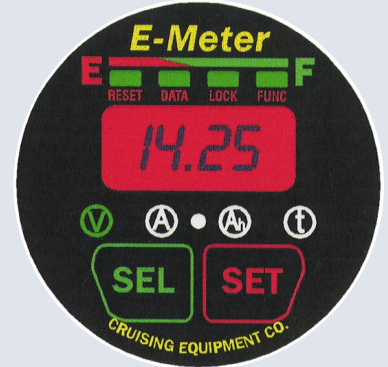

Graphic and Digital Displays

- * Digital Volt, Amp, Amp/Hr Meters
- * Battery Temperature Compensation
- * Monitors Battery Systems 12 to 500VDC
- * Discharge Time Remaining Display for EVs
- * Perfect for EVs, RVs, Marine, and AE Systems
- * Stores Discharge Data, Efficiency, More!
- * User Customizable Setup
- * Price INCLUDES 500A Shunt
- Options
 - * RS-232 output for computer interface
 - * Remote relay output based on A/hrs

In Stock — Call!



- **Photovoltaics** — Solarex - Siemens - BP - Midway Labs
- **High-Quality Batteries** — Trojan - US Battery
- **Power Inverters** — Trace Engineering - PowerStar - Exeltech - AC Genius
- **Instrumentation** — Cruising Equipment - Fluke - Wavetek
- **Charge Controllers** — Heliotrope General - SunAmp - Trace
- **Trackers & PV Mounts** — WATTSUN - Zomeworks - Direct Power
- **Microhydro Electric Powerplants** — Harris Hydro - Lil Otto Hydroworks! - ES&D
- **Pumps** — Solar Slowpump™ - Flowlight - Solarjack - SHURflo - A.Y. McDonald
- **Water Heaters** — Myson - Aquastar
- **Efficient Lighting** — Phillips - Osram
 - Sun Frost • APT • Heinemann • Cutler & Hammer • Square D Products



OptaPhone+
OptaPhone STAR

SOLAREX

SIEMENS
ProCharger 4JF



PowerStar
PRODUCTS • INCORPORATED

Trojan
The Better Battery

SUN FROST

EXELTECH

••• DEALER/INSTALLERS! •••

Anyone can sell you parts. We use and install the components we sell. We KNOW how they work and offer technical support, system design assistance, prompt shipment, fair pricing, and NO BULL. Electrical competence required. Find out why Electron Connection's dealers are prospering!
Write today for your dealer application.



Electron Connection

POB 203, Hornbrook, CA 96044 USA



VOICE • FAX 916-475-3401

Internet: econnect@snowcrest.net

Web Page: <http://www.snowcrest.net/econnect>

A "Turning Point" in Solar Tracking
WATTSUN™ AZIMUTH TRACKERS



Get The Most From Your PV's

- ◆ Positive Gear Drives Deliver 180° Tracking ◆
- ◆ Precise, Battery-Less Controls (PATENT # 5,317,145) ◆
 - ◆ Dual Axis Tracking Optional ◆
 - ◆ 10 Year Limited Warranty ◆

ARRAY TECHNOLOGIES, INC.
3402 Stanford NE, Albuquerque, NM 87107
Tel: (505) 881-7567 Fax: (505) 881-7572

BP SOLAR

b/w
camera ready

3.5 wide
9 high

**THE
POWER
VENT**



**BATTERY BOX VENT
AND
BACK DRAFT DAMPER**



- ◆ Stop cold back drafts.
- ◆ Increase battery capacity.
- ◆ Positive hydrogen venting.
- ◆ Minimal power usage.
- ◆ Uses 1 1/2" or 2" PVC vent pipe.
- ◆ Retrofit to existing systems.

Power Vent \$74.95 plus \$6.00 S & H cont. U.S.
Controller \$49.00 Colo. residents add 3%
(Controller not required with TRACE SW inverters)
Specify 12 or 24 volt DC

Cone Construction ~ Solar Technologies
POB 52, Salida, CO 81201
E-Mail: coneco@rmii.com

719-530-0718

**Dealer Inquiries
Invited!**

The Grid

Michael Perez

©1996 Michael Perez

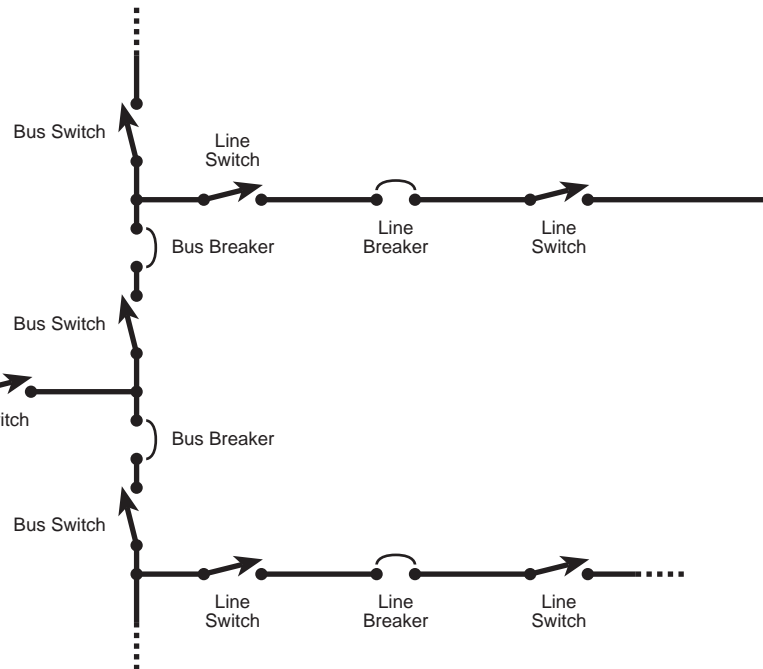
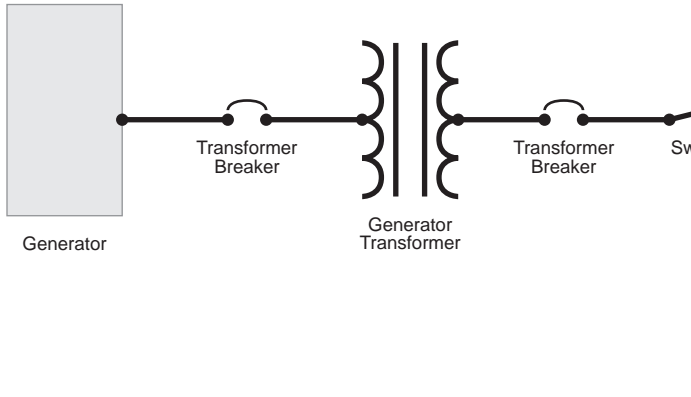

As a long time *Home Power* reader and one who is involved with electrical power, I thought an article on how the “big boys” do it would be informative. Many people are interested in selling alternatively produced energy to their local utility, and many articles have been written on this topic, but I am not sure how many of the readers are familiar with how utilities produce and transfer power through an electrical grid. With increased knowledge comes increased understanding. The description of a system given here is basic and typical, but accurate. Let’s start at the source, the power plant.

The power plant

The typical power plant is large, noisy and, if stream driven, hot. The generators can be stories high and multiples of hundreds of feet long. They vibrate and require lots of auxiliary equipment, electrical and mechanical, to operate. They are staffed continuously, and require ongoing routine maintenance.

Most utilities generate 60 hertz, three phase alternating

current via externally driven turbines coupled to generators. Two popular ways to make the generator’s turbine spin are steam and hydro systems. Hydro, or water, driven turbines consist of large turbine wheels coupled to the electric producing generator unit by a sealed shaft or shaft and gear arrangement. The turbine could be a vaned wheel type with the vanes looking similar to the intake on a jet engine, or the old twirling propeller on the stick toy type, or a paddle wheel type, or squirrel cage wheel type. Water flows over the turbine vanes and the attached shaft is turned, which in turn spins the generator, producing electricity. The same basic idea as some of the home systems detailed in *Home Power* articles, only on a much larger scale. These large units require a steady, non-turbulent water source like a dam with a lake behind it and an abundant supply of water.

The advantages of this system are very low to non-existent fuel costs, low to non-existent pollution, if lake fed, the parallel creation of lakes for irrigation and flood control, low maintenance of the system, and the generator can be “brought on line” (providing power) quickly. The disadvantages are the creation of the lake’s environmental impact including disruption of fish spawning and flooding of land mass, the effect of drought on water supply available for power production, and the high cost of construction and licensing of dams and lakes.

The steam driven turbine, is similarly constructed. The vaned wheel type of device is coupled to a spinning generator via a sealed shaft, but what is different is the power source and turbine construction. Super high

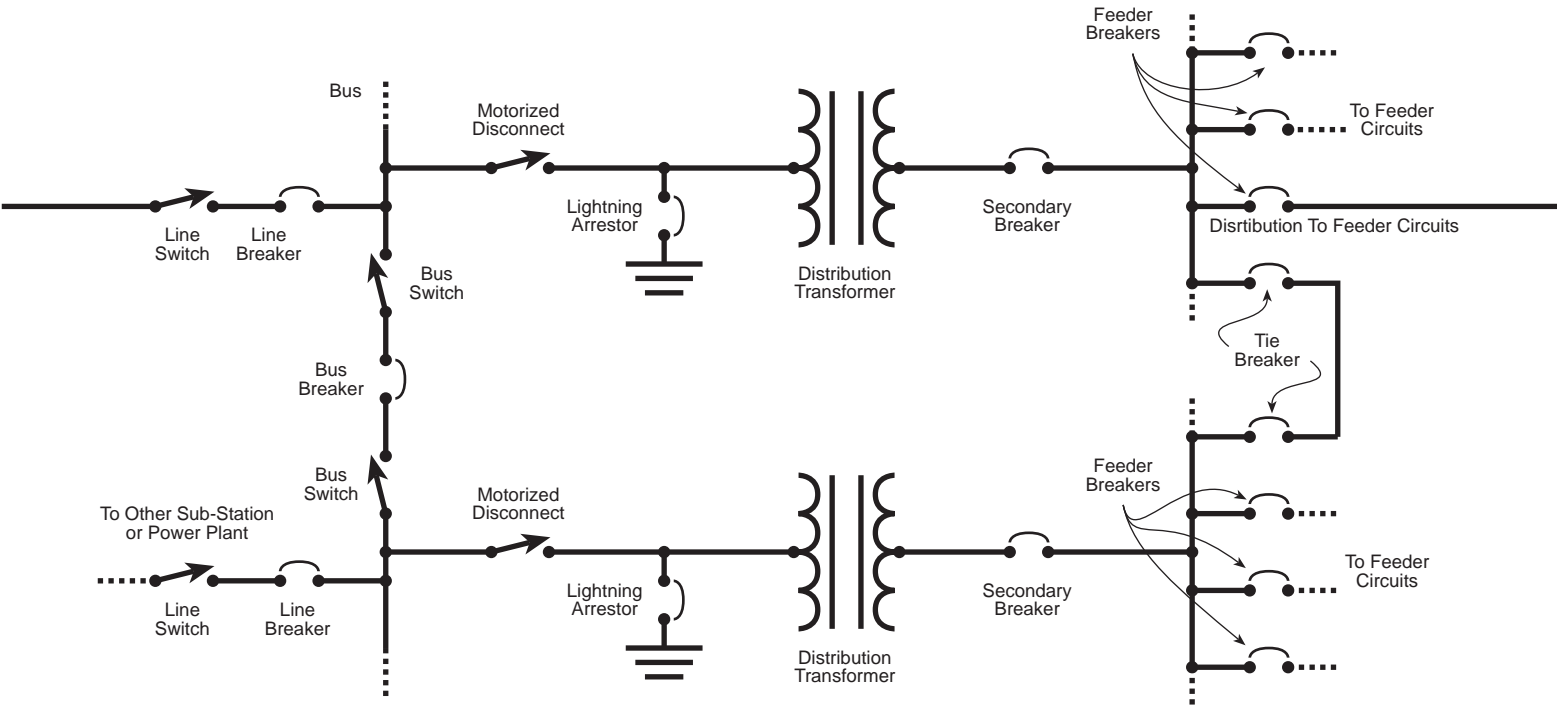

pressure, high temperature pressurized steam is shot at the turbine vanes thus turning the turbine. The fuel to heat the steam can be coal, oil, natural gas, nuclear fuel, manure, trash, or anything burnable. The water is supplied from a river, lake, well, or other source and heated in a closed tube system (similar to non-storage type hot water heaters). The steam is cooled, condensed, and circulated back into a lake or river or reused again by circulating through a cooling tower and back to the plant for heating.

The advantages of steam systems are that they can be located where needed and not near massive water sources, the fuel supply is not subjected to the weather, the technology is proven, the generator output can be closely regulated, and additional units added when necessary using existing infrastructure. The disadvantages to this system are the high fuel costs, the environmental impact (acid rain, nuclear radiation, strip mining, oil drilling, etc.), high maintenance of heated systems, and it can take 24 hours or more to bring a unit "on



Picture 1, Above: On the left a 138 kv highline tower with conductors going to the right to a substation "A" frame dead-end. On the dead end are 138kv disconnect switches in the closed position. In the middle of the picture is a wood pole with an underground riser 3 phase pothead (that's what they call them) going through switches and attaching to a 3 phase 13kv distribution circuit. These circuits would come from a feeder breaker in the switch gear.

line" from a cold start-up. A unit may have to be kept idling (steam pressure maintained) in anticipation of increased loading.

The power produced can be from a few hundred megawatts (millions of watts) to thousands of megawatts, typically high current at a low voltage. The generator output is connected to a step up transformer, which raises the voltage and lowers the amperage. The amount of power remains the same.

The voltage is stepped up to a range of 69 kv (thousands of volts) to 750 kv or higher, with other common voltages of 138 kv , 345 kv, and 500 kv, as measured from one conductor to the other, or phase to phase voltage. Measured from one conductor to ground voltage, would be half the amount. The current at this point is around 2000 amps depending on the generator output. The higher the voltage the further it can be efficiently transported to distribution locations.

The power flows from the generator transformer to a generation sub-

The Grid

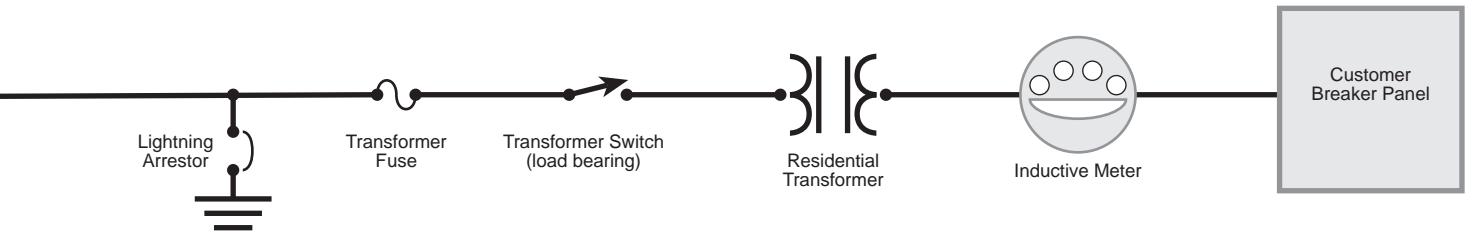

station. This sub-station transfers, or busses, the power in different directions to distribution sub-stations. The power conductors are connected to a three conductor electrical buss, supported by metal, concrete, or wood poles and/or stands and insulators. The buss conductors can be wire, 250 to 500 mcm (thousands of circular mils, which converts to diameters of 0.5 and 0.707 inches, respectively) aluminum or copper, or 2 inch to 4 inch aluminum or copper pipe style buss. Insulators can be ceramic glass with metal attachments at either end, or the newer molded resin type. Both are bell shaped and the surfaces convoluted to offer more surface area for the voltage to “track” or leak over to ground.

All the metal support structures are grounded to a station ground with 4/0 copper wire. This ground is a large copper plate, 2 to 3 feet in diameter, 1/4 to 1/2 inches thick, buried 20 to 200 feet deep with a 4/0 copper wire welded to it. In some areas the ground buss can be a buried grid of welded 4/0 copper that is evenly spaced throughout the station. This ground is tied to all circuits and, along with intermediate ground points, is electrically the ground and/or neutral of the circuits in your house. Circuits leave the buss on three wire conductors, 250 to 500 mcm, attached to towers with ceramic or resin insulators.

On all intersecting points and connections to the buss are high voltage circuit breakers that open the circuit if

the line conductor faults (contacts) to ground and/or the current on the line reaches too high a level. There are switches that allow for isolation of the buss or anything connected to it for maintenance and safety. The circuit breaker functions similarly to the one in your house except being capable of interrupting 2000 amps instead of 20 amps. The older style breaker is a three tank arrangement, each 8 feet high and 4 feet in diameter depending on the line voltage, filled with 690 gallons of insulating mineral oil per tank. The contacts inside are capable of carrying a 2000 amp load interrupting a fault impulse of 650 kv, and are suspended in the middle of the tanks. The total weight with oil is 32,930 lb. These breakers open by a spring action mechanism and can open in 3 cycles (.016 seconds per cycle). The electric buss is attached to two top mounted bushings per tank (on each side of the contact in the tank) that resemble very large spark plugs and are made from ceramic material. The newer style breakers are filled with an insulating gas, SF₆, (sulfur hexafluoride) instead of insulating oil. This gas is capable of insulating from ground 138 kv in a 4 inch space and does not pose the same environment leak risks as oil but is more costly.

The switches are capable of carrying current loads of 2000 amps or more and function like switches in your house by isolating power in a section of a circuit. They are horizontally positioned on large stands with three 6 foot long metal arms with a stationary contact at one end, and on the other end a mechanism to open the



Picture 2, Left: An enclosed metal clad 13kv distribution switch gear. Each of the doors has a 3 phase circuit breaker behind it. On the door are protection relaying and an ammeter for reading each phase current.

Picture 3, Right: 3 phase 138kv disconnect switches as mentioned in picture #1. These switches are in the closed position. If the switches were open (they all open together) then the horizontal long tubes between the vertical insulators would be pointed up from the back of the switch (where the wires go down).



switch from the ground via a coupled crank handle or motorized gear box. When opened the long arms move from a closed horizontal position to a vertical opened position. Not capable of breaking loads (they can't be cranked open fast enough to keep on electric arc from following the switch arm up), they are opened to fully isolate equipment for maintenance after a breaker has de-energized the buss it is connected to .

The circuits leave the generator sub-station on high voltage tower lines. The higher the voltage, the higher the towers need to be and the more insulation from ground potential the conductors have to have when attached to the tower. When viewing an electrical support tower, the more and larger the supporting insulators, the higher the voltage on the conductor. Usually in populated areas the tower lines are 138 kv or 345 kv, with the higher voltages used to buss power through remote areas, thus long distances, from hydro or nuclear plants. A tower line delivers power to a distribution sub-station.

Three conductors, anywhere from 250 mcm to 500 mcm or larger, from a tower are connected to a buss in a distribution sub-station that is similar in arrangement to the buss in the generator sub-station, but with the addition of distribution step down transformers. These transformers convert the power from higher voltage to a

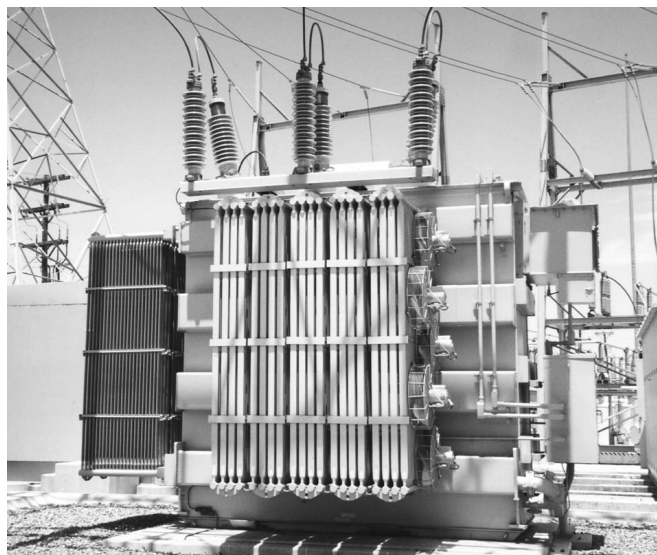

Picture 4, Above: 138kv to 13kv oil filled transformer. Note the radiators and fans for heat dissipation. The vertical insulators in the foreground on top are lightning arrestors and the ones in the rear are insulating bushings which transfer power to the transformer. The box on the top right is a regulating tap changer for changing the tap of the transformer to maintain constant voltage output. This can be done automatically or by the system operator at the energy control center. The data mentioned in the text is from this transformer.

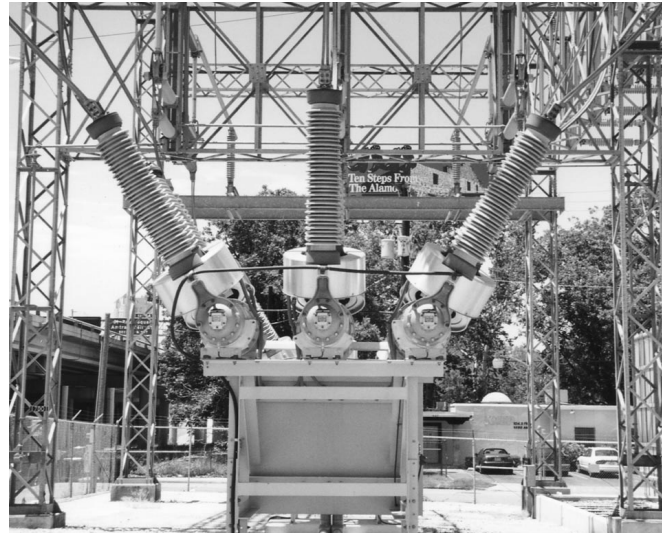

Picture 5, Above: 138kv SF6 filled circuit breaker. There are 6 bushing mounted on the top. Capable of interrupting high current faults (35,000 amps) or carrying a continuous 2000 amps. Note the small size compared to breaker in the next picture. Both are rated the same. Capable of open, in a fault condition, in under 83 milliseconds.

lower voltage range, typically 4 kv, 13 kv, or 34.5 kv, thus increasing the amperage. The transformers are filled with 7000 gallons or more of insulating mineral oil, and weighs 64,000 lb empty, and 163,300 lb filled. They are approximately 13 feet long, 13 feet high, and 6 feet wide. They have the spark plug looking bushings on top for bussing power into them as well as similar looking lightning arrestors. The power at this point is the amount of power from the generator(s) at the plant(s), evenly distributed to the load at all stations connected to the generators(s). The voltage and frequency is highly regulated to all load points.

The power out of the transformer flows into an enclosed metal switch gear or an exposed yard mounted switch gear. The switch gear is designed to split the transformer output into more circuits known as "feeder circuits." Each switch gear has a secondary breaker to isolate its buss from the transformer, and a tie breaker to connect its buss to the output of another transformer in the station. These breakers and the breakers on each feeder circuit are smaller than the previously described breakers due to the lower voltages present. The transformer, through the switch gear buss, supplies power to the feeder circuits that leave the station on overhead lines on poles or on underground cables in groups of conduits called ducts.

The power is still three phase with three conductors of anywhere from #6 copper to 2/0 aluminum depending on the load the circuit is designed to carry. The power flows on the conductors thru right-of-ways to the

The Grid

consumer. Along the lines transformers are connected to the different phase conductors by fused switches and lightning arrestors. These transformers are the step down, oil filled, pole mounted cans that are familiar to most of us. The voltage is dropped again, typically to 220 volts conductor to conductor (or the more familiar 110 volts to ground) but also to 208 volts or other voltages depending on the load requirements. The power to most residential locations is single phase (only one conductor on the pole is connected to the transformer), 220 volt, 100 to 250 amp circuit. This is what goes into the circuit box that feeds your house via an induction type kilowatt hour meter. The service entrance cable, usually 2/0 or bigger aluminum, connects the transformer to the meter.

For underground residential distribution (URD) the power is bussed to the neighborhood from the substation on poles then is transferred to buried cable to either above ground transformers with pad mounts or underground transformers in buried vaults. The path to our house is also underground, but through similar metering and disconnection equipment. The advantage to this method is no unsightly poles and transformers, but the disadvantage is the cable can be dug up, damaged, or fail due to moisture intrusion.

The entire system is monitored and controlled from a centrally located Energy Control Center (ECC) via a computer based SCADA (security, control, and data acquisition) system. This system monitors equipment status and alarms, total system production (all power plant generation, plus power flowing into the system from other utilities) and total system load (all users connected to the system, plus power provided to other

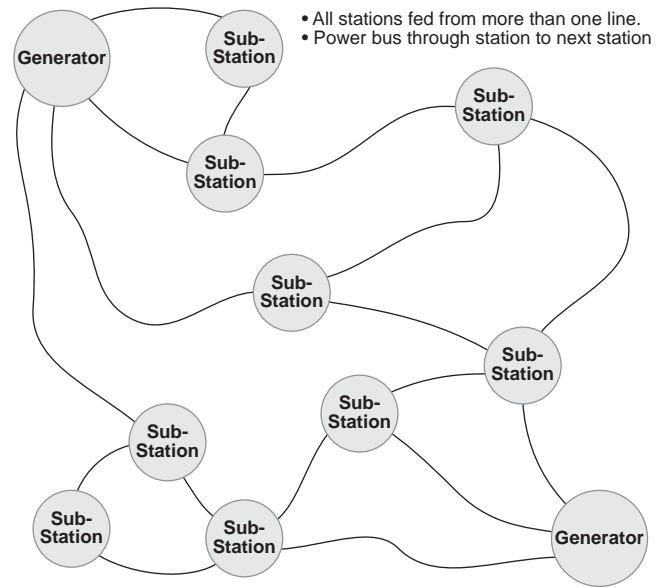

utilities) and constantly adjusts the generators to maintain a 60 hertz voltage stable supply to the load. The SCADA system controls also allow the ECC operators to remotely open and close breakers and switches for maintenance, safety isolation, and for fault restoration. This is done by computer based remote terminal units (RTU's) located in power sub-stations and on poles. They are connected to the ECC located master computer via data communication paths.

All the equipment and circuits that have been described thus far are usually done in multiples, using more than one generator, generator and/or distribution substation, transformer, switch gear, feeder circuit, etc. Each section of the grid, except the final equipment that feeds the load (pole, transformer, and service entrance), is designed to allow for each piece of equipment to be removed from the grid for maintenance or due to failure without customer service disruption. The scheme of automatically switching redundant equipment into service after equipment failure not only allows for highly reliable power (but not fail safe), but adds to the price of the grid. The power grid system in the United States is the envy of the world. The lack of brown outs (low voltage and frequency that is very hard on the "stuff" in your house) and scheduled outages speaks for the emphasis that is placed on redundancy and generation supply by most utilities. The price, while not always cheap, is very competitive with the world market.

There are other components to the grid such as capacitor banks that are used to correct the power factor due to inductive loading, metering equipment, protective line relaying monitoring the tower lines, environmental monitoring and protection, and fuel



Picture 6, Above: Same as picture #5, however filled with insulating oil. The data in the text is from this oil breaker. Each tank has an insulating bushing on top that carries power through the breaker. Each tank has a moveable contact.

transportation and acquisition. Plus large industrial company stuff like communications, billing, meter reading, customer contact, construction and maintenance (power plant, sub-station, building, and transmission line), radio communications to all stations and vehicles, rolling equipment (pole trucks, cranes, bucket trucks, vans, cars, 4 wheel drives, oil tankers, etc), maintenance and management, EEC office, training, safety, accounts payable, purchasing, engineering (underground, overhead, and generation), legal, computer support and networking, personnel, employee benefit, payroll, fuel systems support (pipe line, railroad car, nuclear, dam, etc. maintenance), salvage, and general clean up and maintenance and all the normal support that a large company demands.

Like all things in the universe, the "typical" power grid is subject to change. Things are like they are because that is the way they have always been done and it works—the old "if it ain't broke, don't fix it" idea. We have seen changes in technology that have forced industries to change (seen any slide rules for sale recently?) and I don't believe that the electric utility industry is exempt from that market pressure.

Some of the questions in today's atmosphere of de-regulation, independent producers, and co-generation is what is a fair price for electricity considering all the infrastructure that exists, is needed, and has to be maintained, and who has access to that infrastructure?

I know that there is usually a large difference between what your local utility charges you for power and what they are willing to pay you for power. The common ground here is that both parties can benefit the other. Without all the infrastructure and support that a utility

has, the home producer would have no one to sell power to. With the independent producer on the line, peak loading in the middle of the day could be lowered and new generation facilities down-sized or postponed, thus increasing profits or at least lowering liabilities and debts. Also, with individual generating stations along the line, lines can be made longer, thus less sub-station equipment is needed and the number of feeder circuits reduced.

The pros and cons go on and on, but the driving force behind the whole process is dollars. The utilities don't want to give up their revenue and monopoly, and with the independent producer on the line, safety is compromised because the ECC may not have control, without extra expense, over whether or not a line is properly de-energized. The independent producers want to recover as much of their investments as possible by getting a high price for their power. I know the environment and renewable aspects and agree with them. However, if the independents have only the environment in mind, then they would hook to the grid and supply all they could for the good of the environment at any price. If the local utilities had the best interest of their customers in mind, then allowances for independent producers sharing in the process would be encouraged. Regardless of the situation, I hope that this article has helped in some small way to depolarize the debate by providing a glimpse into the "THE GRID".

Access

Author: Michael Perez, 320 Shadwell Drive, San Antonio, TX 78228 • 210-737-1078



Harris Hydroelectric

Hydro-Power for Home Use

Works with heads as low as 10 feet • Price starts at \$750

New Features:

- 17 bucket reshaped Pelton wheel
- Powder coated castings
- More efficient stator in high output models

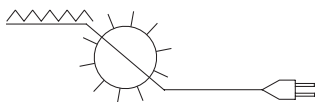

632 Swanton Road
 Davenport, CA 95017
 408-425-7652

*"The best Alternator-based MicroHydro generator I've ever seen."
 Bob-O Schultze, Hydroelectric Editor, Home Power Magazine*

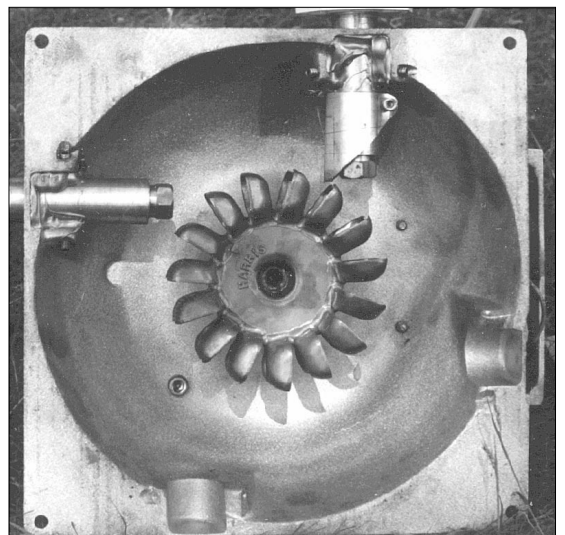

Slave PV Charge Controller

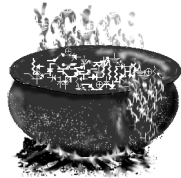

Homebrew

Mike Lapointe

©1996 Mike Lapointe

The idea—Supplement the current capacity of your existing relay-based controller

My situation was a house my wife and I rented on the Big Island of Hawai'i. It had a 120 watt fixed array of second hand panels. The system was fine for our lights and water pump, but insufficient for our one luxury—our desktop computer. Purchased before the Energy Star program took hold, it consumes a scandalous 200 watts. Our landlords, who live in the house themselves part of the year, were kind enough to agree to purchase additional panels, which they themselves would enjoy when we left. However, the charge controller could not handle the additional load. This circuit enabled the existing unit to control more current without modification.

The simplest solution for most older charge controllers is replacement. Perhaps a newer, snazzier model appeals to you. But if you're reluctant to relegate your controller to the junk box and shell out the bucks for a new one, you may be able to use this circuit to increase your charging current capacity—cheaply.

What it does

This simple circuit, installed alongside your existing charge controller, simply parrots whatever your controller does. When your controller (the master) closes its relay to allow current to flow into the batteries, this circuit (the slave) closes its own relay. When the master opens its relay to analyze the battery and PV voltages, the slave opens its relay also to avoid affecting the master's analysis. When the master opens its relay for the night, the slave follows. This second relay allows another bank of PVs to be connected in parallel to the first, effectively increasing your charge controller's current capacity.

Circuit operation

When the circuit is in the 'on' state, resistor R4 feeds current into transistor Q4's base, turning it on and energizing the relay. Transistor Q3, when turned on, will steal the base current from Q4, turning off the relay. The purpose of Q1 and Q2 is to turn on Q3 when appropriate.

The slave circuit has three sensing leads which are attached to the corresponding terminals of the master charge controller: negative, PV+, and battery+. By comparing the voltage difference between PV+ and battery+, the slave recognizes the three basic states of the master controller:

- **charging: master relay is on** (PV+ = battery+)
- **analyzing: master relay is off** (PV+ > battery+)
- **nighttime: master relay is off** (PV+ < battery+)

When PV+ equals or very nearly equals battery+, neither Q1 nor Q2 is on, so Q3 stays off and Q4 conducts, energizing the relay. When PV+ exceeds battery+ by about 0.5 volts, Q1 is forward biased and conducts, turning on Q3 and turning off Q4 and the relay. When battery+ exceeds PV+, Q2 is forward biased and conducts, turning on Q3 and turning off Q4 and the relay. The remaining elements of the circuit are for fine-tuning or information, and are not central to the basic operation. The assembly consisting of D1, R5, and R6 allows fairly precise adjustment of the shutoff voltage when PV+ falls below battery+. Originally, I connected R2 directly to PV+, meaning that PV+ had to be about 0.5 volts below battery+ before the relay would shut off. While I didn't believe this level of reverse voltage to the PV array to be harmful, I decided to make it smaller. Potentiometer R6, serving as a voltage divider across the relatively constant voltage of D1, allows adjustment between 0 and 0.5 volts. D2 serves to clamp voltages generated when current is shut off to the relay coil. R7 and D3 are simply to provide visual feedback when the relay coil is energized.

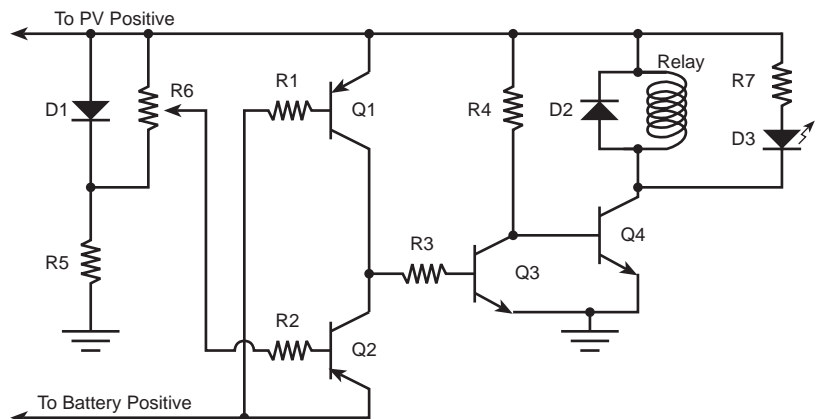

Construction

My component cost for this circuit was approximately \$2, as the relay cost me \$1, and the remaining parts were pennies apiece. If you were to purchase all the parts via mail order, it would probably cost about \$4, ignoring s&h and minimum orders. Radio Shack would be approximately \$10. No matter which way you go, it beats the price of a new controller. I built the circuit on a piece of perfboard approximately half a square inch in size so as to fit it into the case that came with the relay. While I was successful, I suggest you allow yourself at least twice as much room, as that was quite cramped. It would be a good precaution to use a case which can be sealed against the elements if the circuit will be mounted outside.

My circuit as built consumes 0.6 milliamps when in the off state, and 48 milliamps when on. Your mileage may vary depending on your relay. I discovered that my '12 volt' relay reliably pulled in at slightly less than eight volts. This meant I was able to put a 100 ohm resistor in series with the relay coil to decrease current consumption by almost 40%. I detected no loss in performance.

Adjustments

I recommend setting R6 such that Q2 turns on when battery+ exceeds PV+ by 0.1 volts. Attempting to adjust this too close to zero may cause Q2 to operate improperly. A tenth of a volt also allows a little room for operational variations due to temperature. You can do this on the bench before installing the unit if you have two sources of voltage, one of which is 12 volts, and the other 0.1 volts less. If you only have one power supply, just make a temporary second one with a potentiometer. Once you have your input voltages set to battery+ = 12.0 and PV+ = 11.9, adjust R6 until the relay clicks. D2, the clamping diode, must be able to handle the amount of current that will be passing through the relay coil. Unless you have a really big relay, this should not be a problem. The relay you use determines how much current you can switch, and makes up the bulk of the cost of this circuit. You should make sure that the current required by the relay coil can be safely supplied by Q4. According to the semiconductor reference I got from Radio Shack, a 2N3904 can supply up to 200 ma. If you need more than this, consider another transistor—you may have to adjust R4 to match the new transistor's base current requirements.

The component values for this circuit are not too critical. Substituting a few different small-signal transistors yielded satisfactory results. With so few components, it would be faster to try what's in your junkbox before running out to get something.

While this circuit was designed for a 12 volt system, it should work without any modification for a 24 volt system. I do not recommend using it as is for higher voltages as the breakdown voltage of the transistors specified could be exceeded. However, I am aware of nothing about the basic design that prevents it from being used at higher voltages.

Requirements and caveats

The negative leg of the batteries and the negative leg of the primary PV array must be permanently connected for the circuit to work properly.

The circuit will not work with pulse width modulation (PWM) controllers. The length of time necessary to switch a mechanical relay on and off far exceeds PWM requirements. If an n-channel enhancement mode FET (without an internal diode, which would allow current to flow back into the panels at night) were substituted for Q4 and the relay, the circuit might switch fast enough to work. I haven't tried this, as I don't have access to a PWM controller. Some controllers have very short analyze periods—the time during which the current is shut off so the controller can analyze the voltage of the panels and the batteries. My prototype was very quick to follow the master controller—the two relay clicks were almost indistinguishable. If your controller uses a solid state switch instead of a relay, the analyze period may be too short, presenting the same problem as PWM controllers.

The slave circuit will not follow the master exactly at dawn and dusk, when the PV voltage is very close to the battery voltage. The slave circuit doesn't know whether the PV and battery voltage are equal because the master turned on its relay, or because it's time for night and day to change places. In my tests, I experienced about thirty seconds each morning and evening when the slave relay turned on as the PV and battery voltages passed each other. Since the reverse voltage presented to the PV array is so low, there should be no problem.

Parts List

<i>Part</i>	<i>Description</i>
Q1, Q2	2N3906 (PNP)
Q3, Q4	2N3904 (NPN)
R1-R4	33kohm
R5	50kohm
R6	50kohm linear potentiometer
R7	2.7kohm
D1, D2	1N4008
D3	LED

I did not actually test the circuit at temperatures below 50° F. Living in Hawaii, we didn't get much cold weather. I do have a circuit simulator which simulates performance at different temperatures, and I used the results to design the circuit with some room for temperature variations. In hindsight, I should have extended the wiring into our tiny freezer, but I no longer have access to a PV system to test it. The most likely failure would be insufficient base current at low temperatures, which would be fixed by reducing the values of R1-R4.

Alternate Uses

Another way to look at this circuit is that it closes a relay when your controller is charging. Anything you want to turn on (or off, depending on your relay) is fair game. The simplest application would be a remote charge indicator. Or perhaps you have a load that you only want to operate when your panels are producing—assuming you don't mind it turning off during the controller's analyze period.

Conclusion

The circuit, once installed, took orders from the master flawlessly for several months. Eventually we moved away and, for reasons unimportant here, I ended up taking the circuit with me. It is no longer in operation, but I have no reason to doubt that it would still be working properly. Why didn't I use a comparator instead of transistors, you might ask? If you did ask, then you probably know enough to design a similar circuit based on a comparator. I used transistors because I was trying to get more experience designing transistor circuits. In this era of VLSI miniaturization, I was tickled that a useful circuit could be composed of a baker's dozen of discrete components.

Access

Author: Mike Lapointe, Internet Email: mikel@i3.attmail.com or c/o Home Power, PO Box 520, Ashland, OR 97520



HITNEY SOLAR PRODUCTS, INC.
Harmony with Nature

Distributor for:
SEIMENS SOLAR INDUSTRIES
TRACE ENGINEERING
HELIOTROPE
MORNINGSTAR
S.C.I.
SHURFLO
ZOMEWORKS

P.O. Box 365, 2655 N. Hwy 89, Chino Valley, AZ 86323
Office (520) 636-1001
Fax (520) 636-1664

SNORKEL STOVE CO

camera ready
b&w

3.35 wide
3.35 high

ADVANCED COMPOSTING SYSTEMS

camera ready
b/w

7.1 wide
2.25 high

EXELTECH

black and white
camera ready

7.2 wide
4.6 high

Specializing in **COMPLETE** systems design

*Solar Electric, Heating, Water, & Appliances
Including complete CAD design services*

We can supply everything
you need to be off-grid...
inverters to modules to
batteries, including your
kitchen stove

TRACE • SOLAVOLT
APT • BUDERUS
THERMOMAX
WATTSUN
SOLARJACK • IBE
PEERLESS-PREMIER
GAS RANGES



**PLANETARY
SYSTEMS™**

P.O. Box 9876
2400 Shooting Iron Ranch Rd.
Jackson, WY 83001

Phone / Fax 307-734-8947



The 1996 TriMetric

VOLTS, AMPS & AMP-HOUR Battery System Monitor

Now with 7 new data monitoring functions.

(All 7 are available if you need. Easy to ignore if you don't)

Here's one of them and how it may be used...

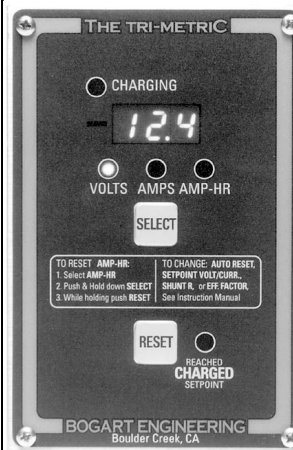

Hours since "charged": Shows how long ago since the batteries were fully charged. If you have lead-acid batteries, when this time gets too high—you need to give them a boost (possibly with a generator) to get them fully charged to keep them healthy. It's a lot easier for the **TriMetric** to keep track of this than you! Reads 0.1 hour to over 6000 hours.

Also Monitors:

- Maximum Volts •
- Minimum Volts •
- Lifetime amp-hour usage •
- One cycle efficiency factor •
- Deepest discharge •
- Amp-hours used since last charged •

Optional adapter for 48 Volt systems / lightning protection
Call your R/E distributor or us for more information
Suggested retail: \$169 without shunt

BOGART ENGINEERING

19020 Two Bar Road, Boulder Creek, CA 95006 (408) 338-0616

Sundown Timer

Jeff Green ©1996 Jeff Green

I had a problem to solve with my new Trace 4048 hooked to a single circuit in my house in Frankfort, Illinois. My outdoor fluorescent lights on the inverter circuit draw electricity all day long just to detect light. This is an expensive energy penalty in terms of photovoltaic electricity. My wife Priscilla and stepdaughter Amelia want the lights on when they come home at night. This leaves the door open to automatic controls.

Dawn of the Sundown timer

I want the inverter in sleep mode drawing minimal power during the day and the lights off by 10:00 or 11:00 at night. Ideally this would be a photo-timer detection circuit. It would detect the sun going down in the evening, triggering a relay to turn on the outdoor lights. Then it would start a timer which could be variable in nature and shut itself off when done.

Resources already available

Out in my garage is a Trace 2512 operating my garage doors. There are two Solec 53 Watt panels charging four 220 Amp-hour Trojan batteries. The solar panels will change voltage eventually to zero Volts indicating that the sun has gone to sleep for the night. The batteries provide the electricity for operation of the photo-timer circuit.

Wiring

I buried 20 AWG telephone wire in flexible 1/2 inch plastic tubing about 6 inches in the ground. 12 Volts runs through the wire to relay on the outdoor light pole. Pulling the wire through the plastic tube was next to gruesome. My wife and I took over an hour threading the wire puller through. It loves to catch itself on the walls of the tube.

The outside of the box

There are two sets of inputs to the circuit. The battery and PV panels. There is one output on the box. This runs the relay on the light pole. I have a twelve position switch to select 1 thru 9 hours or leave it on all night long. 40 leds are also on the outside of the box. Each

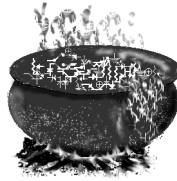

Homebrew



Right:
Sundown Timer
outside

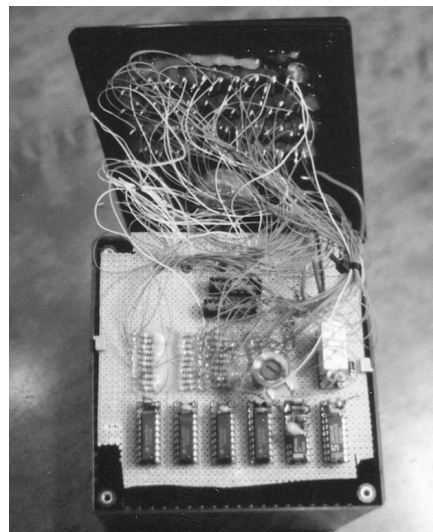

Left: inside

led in four rows of ten represents an output from the decade counters.

The inside of the box

Wire wrap is used to connect the circuit together. Seven sockets are used for six ICs and one relay. 40 resistors that correspond with the 40 leds on the lid of the box are mounted on the perf board. Two low-current reed relays are also mounted through the perf board.

Circuit description—or, all in a night's work

1. Sundown detection

The LM324 comparator is used to detect the sun going down from the solar panels. The battery voltage is divided by ten for input into pin 3. Pin 2 is hooked directly to the PV panels. I chose a low voltage for switching over to get by those cloudy days without having lights on all day. When pin 1 goes low, this turns on K1.

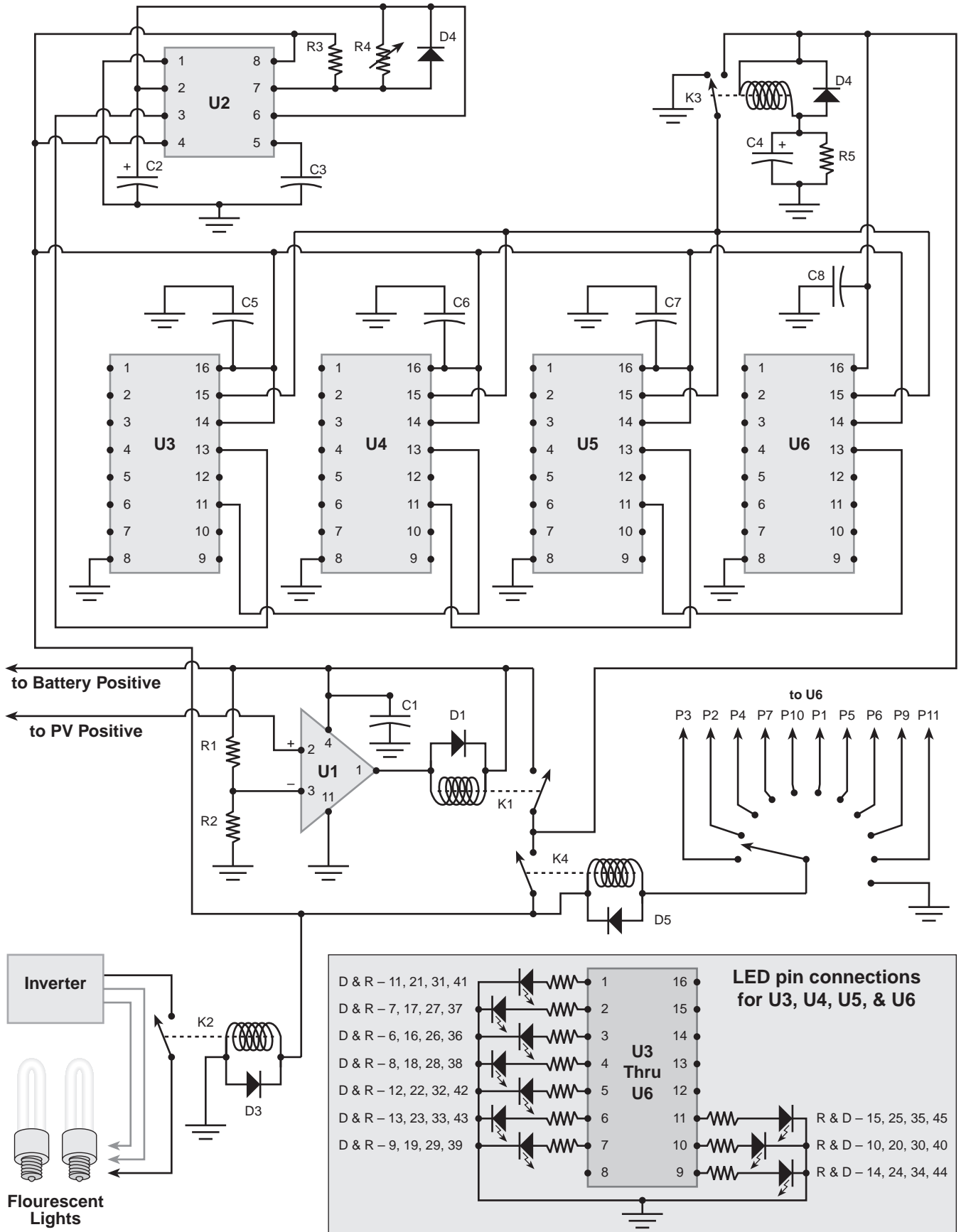

SUNDOWN TIMER PARTS LIST

PARTS	DIGI-KEY PART NO.	COST
R1,R5	100K + Q + BK-ND	\$0.28
R2 10K	10K + Q + BK-ND	\$0.28
R3 56K	56K + Q + BK-ND	\$0.28
R4 500K POTENTIOMETER	3309P-504-ND	\$0.80
R6-R45 1K	1K + Q + BK-ND	\$2.24
C1,C3,C5-C8 100PF MONO	P4800-ND	\$1.08
C2 22uF TANTULUM	P2051-ND	\$1.83
C4 100uF ELECTROLYTIC	P6239-ND	\$0.18
D1,D3-D6 1N4006	1N4006CT-ND	\$0.73
D2 1N4148	1N4148	\$0.56
D6 THRU D45 RED LEDS	HLMP-3300QT-ND (40)	\$4.48
K1,K4 REED RELAY	Z624-ND (2)	\$7.92
K2 SPDT	Z779-ND	\$3.29
K3 SPDT	Z721-ND	\$1.85
S1 12 POS. ROTARY SW.	EG1952-ND	\$3.78
U1 LM324	LM324-ND	\$1.26
U2 555 TIMER	LM555CN-ND	\$0.88
U3-U6 DECADE COUNTER	CD4017BE-ND (4)	\$3.80
20 AWG TELE. WIRE 120'	FROM HDW. STORE	\$9.60
5/8" O.D. FLEX. PVC TUBE	FROM HDW. STORE	\$21.00
PLASTIC ENCLOSURE BOX	HM124-ND	\$10.91
WIRE WRAP SOCKETS (6)	ED4320-ND	\$13.74
TOTAL		\$90.77

2. K3 resets counters

K1 turns on putting 12 Volts on K3 and U6. K3 is turned on hitting reset high on U3, U4, U5 and U6. The capacitor on the ground side of K3 appears as a short momentarily. As the capacitor charges, the voltage rises and turns off K3. The parallel 100K resistor bleeds off the cap in case the circuit would turn on and off in a short time. U6 is turned on first to turn on K4.

3. U6 and the rotary switch

Each output of U6 is connected to the rotary switch. If S1 is set to U6-P3, the timing circuit will not start up. At reset pin 3 will be a high, keeping K4 off. If S1 is set to any of the other outputs, the timer circuit will turn on and count. Nine different time positions are based on the available outputs of the counter. The 11th position is tied to ground to bypass the timer. This will leave the lights on all night.

4. K4 turns on the counters

K4 is engaged and turns on the rest of the circuit. K4 also turns on K2 which is outside on my light pole. Now my lights are on outside at sundown. One to nine hours later they will be shut back off.

5. Setting the U2 timer

When the circuit is built and working, the timer can be

adjusted. This is where the LEDs come in handy. I set up the rotary switch S1 to have one hour between detents. On the top of my box, one hour is the 2nd led in the bottom row. It takes 1000 counts to get to this LED. There are 3600 seconds in an hour. This means I want 3.6 seconds per count or 36 seconds for ten counts. The timer can be adjusted with the 500K pot of U2. The second LED of the second row will turn on in 36 seconds. With a stopwatch this time can be adjusted using the 500k pot.

6. Shutting the lights off

When K4 gets a high from U6, K4 will turn off. This shuts down U2, U3, U4, U5 so that counting stops and less current is drawn. U6 is on showing where it has stopped for the night. K4 also disengages K2 shutting the lights off for the night. This condition is maintained until sunup. At this point U1 turns off K1 shutting off power to the entire circuit. Now the current draw is only the LM324 which is less than 1 mA.

Improvements

Ideally I would have sundown detection and a clock to turn off at my preset time. I don't have precise control over when the lights turn off. If possible, I would have a microprocessor programmed as a clock. The LM324 would detect sunrise and then the clock shuts off at the precise time I set.

Energy draw

I assume 8 hrs for a worst case scenario for each state.

Daytime:

$$0.95 \text{ mA} \times 13 \text{ Volts} \times 8 \text{ hrs} = 0.099 \text{ Watt-hours}$$

Lights on:

$$69 \text{ mA} \times 13 \text{ Volts} \times 8 \text{ hrs} = 7.176 \text{ Watt-hours}$$

Lights off:

$$15 \text{ mA} \times 13 \text{ Volts} \times 8 \text{ hrs} = 1.560 \text{ Watt-hours}$$

Total = 8.835 Watt-hours

This scenario would take about 11 minutes of sun from a 50 Watt panel on a sunny day.

Wrap up

While writing the article, I installed the Sundown Timer out in the garage. It turns on automatically at sundown and shuts the lights off after we have gone to bed. My wife and daughter truly enjoy arriving home at night to a house and yard with lights on. This gives them the feeling that their home has life and vitality in it. I've helped them have that feeling while keeping my inverter in its sleep state with utility designed lighting. I enjoy building electronic projects to meet my family's needs and conserving energy at the same time. I also love to listen to other ideas from people in renewable energy. Please give me a call or send an email message

introducing yourself. I hope my ideas can help someone in meeting their family's needs.

Access

Author: Jeff Green, 102 S. Maple, Frankfort, IL 60423 •
815-469-5334 • Internet Email: Jeff_Green@msn.com



FOWLER SOLAR ELECTRIC

226 Huntington Road PO Box 435
Worthington, MA 01098
1-800-914-4131

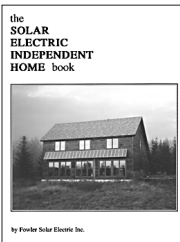

This is the most popular book for PV remote homes. It is written and published by Fowler Solar Electric Inc.
"Best all around book on wiring your PV system."

1991 Real Goods Sourcebook
"Our favorite book for Do-It-Yourselfers."

Windy Dankoff, Flowlight Solar Power
"This should become the bible for alternative energy users."

Ken Cox, President Trace Inverters

\$16.95 plus \$2 UPS

(includes our \$3 catalog)

Send \$3 for our 64 page catalog and product guide

Servel/Dometic Gas Refrigerators. Trace Inverters. Trojan Batteries.
Siemens & Solarex PV modules, Osram Bulbs. Thinlite Fixtures
AquaStar Hot Water Heaters. AIR 303 Wind Generators

Best book, most user friendly catalog, & best kits in the business.

Ask about our full line of Carrizo Used Solar Panels:

ARCO 16-2000	\$169
ARCO M52 Gold Tri-panels	\$379
ARCO M52 Super-Gold Tri-panels	\$469
ARCO M52 12V Conversions	\$179

ALTERNATIVE ENERGY ENGINEERING

camera ready

b&w

3.5 wide

9.2 high

WINDSTREAM®



WIND
GENERATORS
FOR CHARGING
12 VOLT BATTERIES

FOR COTTAGE,
RESIDENTIAL,
MARINE, RV,
TELECOM AND
WIND - SOLAR
APPLICATIONS

BUILT TO LAST!

WIND TURBINES
FOR ALL USES

SOLD WORLDWIDE

CONSTRUCTION PLANS,
KITS AND ALL PARTS
AVAILABLE

HAND AND PEDAL
GENERATORS

MICROHYDRO SYSTEMS

PERMANENT
MAGNET
GENERATORS AND
ALTERNATORS

WINDSTREAM POWER SYSTEMS INC.

ONE MILL STREET
POST OFFICE BOX 1604-HP
BURLINGTON, VT 05402-1604

TEL 802 658 0075
FAX 802 658 1098

MANUFACTURING WIND AND WATER POWER SYSTEMS SINCE 1976

STATPOWER

b/w

camera ready last printed in HP50, page 37

7.3 wide

4.5 high

Solar Electric Power

Complete Systems...
Remote Homes • Water Pumping • RVs
Lighting • Telecommunications



- The Infinity 6...
- 100 Amp Charge Control
 - Remote Access
 - Volt, Amp, & Amp-Hr Meter
 - UL Listed

Distributor Inquiries Welcomed

A Premier Manufacturer of Quality Solar Products

SunAmp Power Company



7825 E. Evans Rd., Ste. 400
Scottsdale, Arizona 85260



1-800-Mr-Solar

AUTOMAGIC BATTERY WATERING



WE MAKE WATER FROM YOUR GAS

Hydrogen and oxygen battery gas catalytically recombined into pure water and returned to each battery cell. Keeps battery topped off for extended periods of time and reduces maintenance costs. Explosive hydrogen gas is virtually eliminated from the battery area. Corrosive spray and fumes are contained and washed back into each battery cell. Electrolyte kept strong longer, extending the useful power and life of the battery. HYDROCAP Vents simply replace the battery's caps. Battery maintenance is greatly reduced. Write or call for more information.



Things that Work!

Hydrocap
CATALYST BATTERY CAPS®

305-696-2504
975 NW 95 St.
Miami, FL 33150

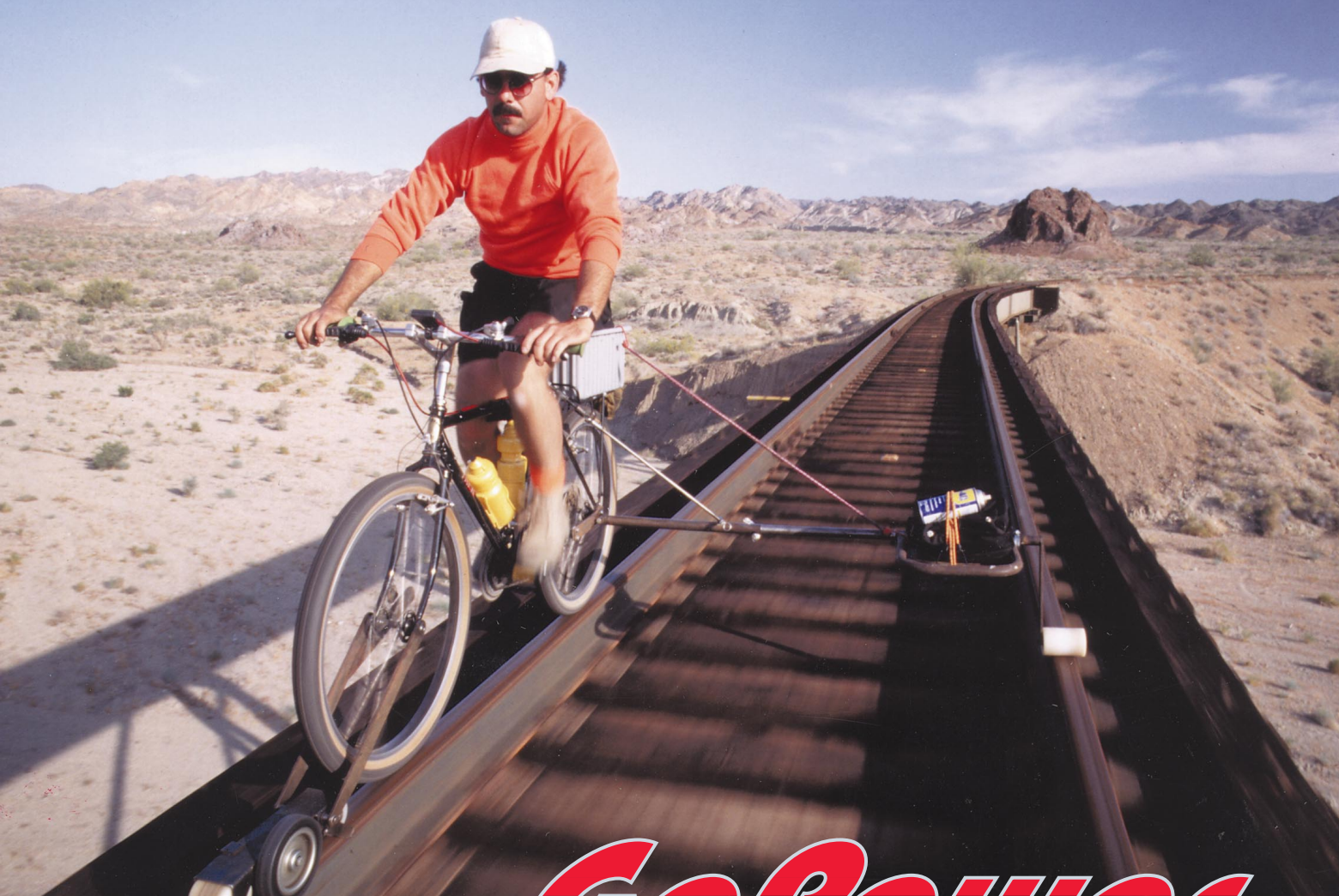

GoPower



The Good, the Bad, and the Testbed

Michael Hackleman

©1996 Michael A. Hackleman

A Solectria entry in the most recent Tour de Sol went 370 miles on one charge! While these are not batteries you and I can buy right now and are unlikely to be affordable, they have propelled a multi-passenger vehicle beyond the range of a standard tank full of gas. Phil Jergenson commented, "Why isn't that headline news?" Good question! Good job, Solectria. And our western hats off to the other side of this fair continent in the form of the North Eastern Sustainable Energy Association who put on the multi-state, multi-day event.

ZEV mandate

I've some bad news to report. The 1998 mandate of 2% ZEVs is dead. Alas, the California Air Resources Board succumbed to pressure from oil companies, the big three, the governor, and substitutions on the board. The auto companies promise they'll do EVs as soon as they're practical. Cross their hearts and hope to die. Hey, my hat is off to CARB's attempts on our behalf. A righteous effort.

Prototyping

I get a lot of mail (post office, HPBB, and internet) from hobbyists or enthusiasts wanting to put something together some kind of vehicle. My standard response is to suggest building and competing in Electrathon-style vehicles. This provides the support group and inspiration your project might need during the doldrums. You know. The doldrums. Waiting for parts. Looking for parts. Looking for money for parts. Wondering how to assemble the parts. The doldrums.

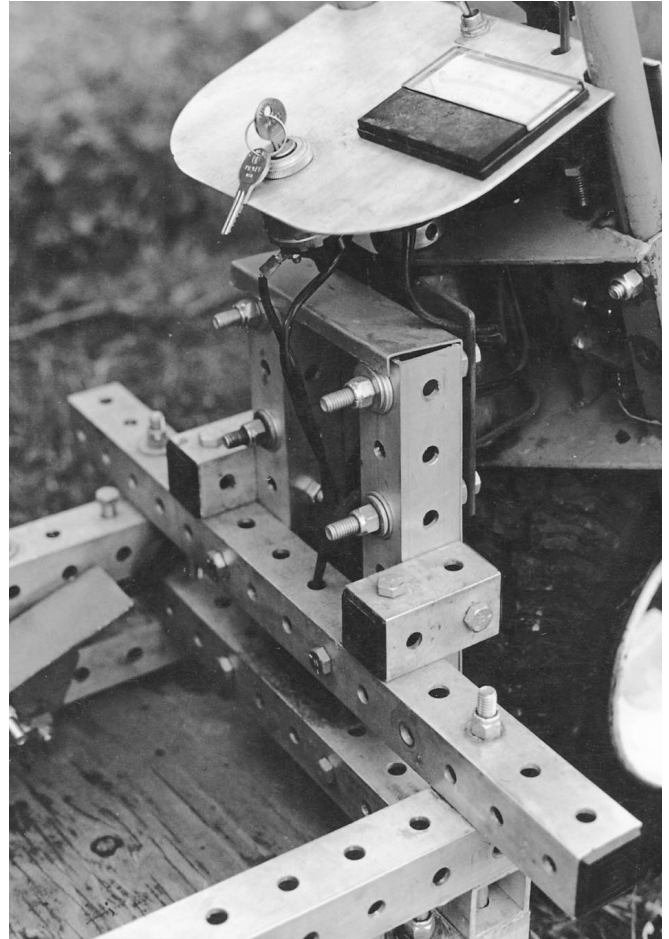

HP readers ready for something tougher or bigger ought to consider a mockup. Using BoxBeam during the Panther Electric project convinced me of the merits of this (or other building systems, e.g., Telspar) for prototyping. Since BoxBeam is available in wood or aluminum, I now use wood for prototyping and substitute aluminum when I'm ready to install components. Wood is generally nicer to work with, isn't as noisy when dropped, and feels acceptable in a living room. It beats aluminum in a cold shop space, too!

A vehicle testbed is important. Some people are skilled enough to move from the drawing board to a shaped, welded spaceframe. Not me. For prototyping, I want something that lets me build fast and change things easily. I have framed a layout with BoxBeam AND worked through many refinements in one evening's time. Early positioning of components relative to one another and being able to sit in the mockup helps me slip gracefully by major mistakes.. There's something tangible about a layout that will shapeshift.

I was surprised by how small an amount of BoxBeam was actually used to build the Panther Electric. It figured to less than 35 feet (donated by Phil

Jergenson). At the current rate for wood (\$1.25/foot, plus shipping), that's less than fifty bucks of materials! Since Phil is an avid prototyper, I decided to find out how much material was used in a variety of electric vehicles he has engineered and assembled (all detailed in the BoxBeam sourcebook). Here's the result in pounds: Vanda runabout (128), Willits HS Electrathon (30), the all-terrain Scamp (23), a new work cart (38), Solar Bear tractor (99), and the X-Wing runabout (65).

I encourage HP readers to share their favorite prototyping materials and techniques.

This Issue

Did you go to the electric car races this year? If not, check out The EV-olution of Phoenix Racing, by Shari Prange. For balance, I've assembled Riding the Rails to cover a new sport, railbiking. Richard Jergenson said it best, "There's the fast track, and then there's the slow track." And that's a GoPower wrap.

Access

Michael Hackleman, PO Bo 327, Willits, CA 95490.
email: michael.hackleman@homepower.org

SunTools (Phil and Richard Jergenson), PO Box 1029, Willits, CA 95490. (707) 459-2624. BoxBeam Sourcebook (96 pages, \$23) supplies extensive detail on all of these vehicles.



ELECTRIC VEHICLE

COMPONENTS, CONVERSION KITS, PUBLICATIONS, VIDEOS, AND ENGINEERING DESIGN SERVICES FOR THE EV HOBBYIST AND MANUFACTURER...All components selected with safety and reliability foremost in mind....We stock and sell the largest variety of the very best:

- ◆ ADVANCED DC Motors in 9 variations from 2 HP to 28.5 HP
- ◆ CURTIS-PMC Controllers, Throttle Potboxes, Footpedals
- ◆ ALBRIGHT ENG. Main & Reverse Contactors in 6 models
- ◆ GENERAL ELECTRIC & HEINEMANN Circuit Breakers
- ◆ BUSSMAN Safety Fuses from 200 to 800 amps
- ◆ DC-DC Converters from 48 to 200 V input
- ◆ K & W ENG. & BYCAN Battery Chargers from 48 to 144 V
- ◆ Full line of CURTIS, WESTBERG, & KTA Meters & Gauges
- ◆ DELTEC Meter Shunts from 50 to 1000 A
- ◆ EVCC Adapter Plates, Couplings, Clamps, & Brackets
- ◆ PRESTOFLEX Welding Cable, MAGNA Lugs, Assy. Tools
- ◆ CONVERSION KITS for vehicles from 300 to 5000 lbs.
- ◆ Complete ELECTRATHON Drive & Instrumentation Pkg.
- ◆ 3 Complete GO KART kits...for up to 90 mph..

COMPONENTS & PUBLICATIONS CATALOG.....\$5.00

KTA SERVICES INC.

Electric Vehicle components and systems since 1984

944 West 21st Street – Upland, CA 91784 USA

Tel: (909) 949-7914 – FAX: (909) 949-7916

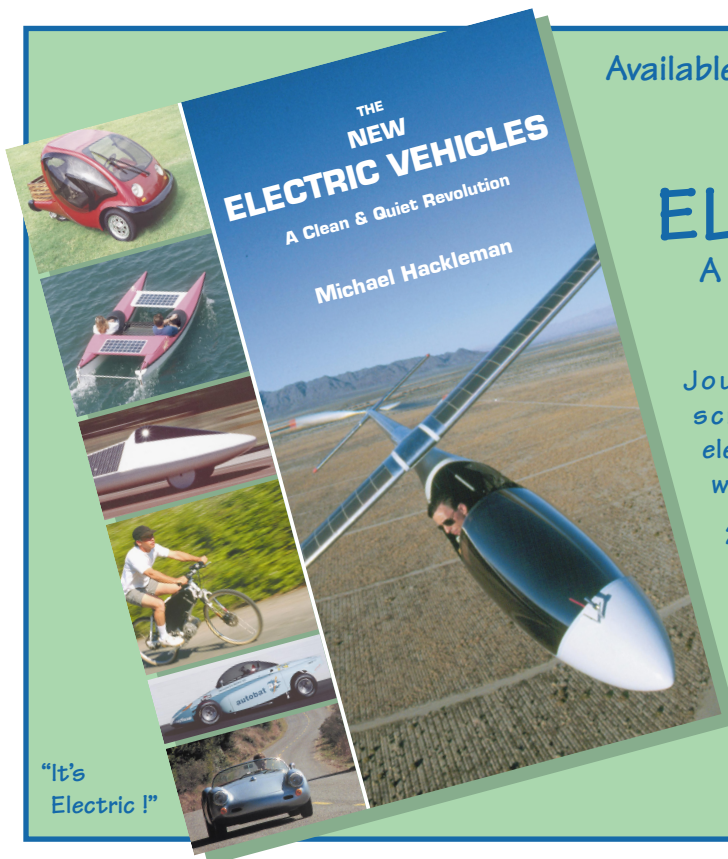

Available Now! Only \$25 (outside USA add \$5 for shipping)

THE NEW ELECTRIC VEHICLES

A Clean & Quiet Revolution
by Michael Hackleman

Journey into the world of conversions, scratchbuilts, human-electrics, solar cars, electrathon racers, planes & boats—all powered with electricity.

272 pages of EV technology, 465 photographs (over half in color), and detail on 65 vehicles. Includes 115 technical design and construction sidebars.

To order Call: 800-707-6585

Outside USA call 916-475-0830 • Fax: 916-475-0941

or write to:

Home Power Publishing
PO Box 275 • Ashland OR 97520



HOME POWER T-Shirts

100% Cotton = Good Shirts



Full Color on White Shirt
\$15.00



Full Color on Black Shirt
\$20.00
(they cost more to make)

Sizes:
S, M, L, XL, XXL

To Order Call: 800-707-6585

916-475-0830 Outside USA

-or-

Send Check or Money Order to:

Home Power Magazine

PO Box 520

Ashland, OR 97520

-or-

See Our Web Site: www.homepower.com



Plant a Solar Seed...

Home Power and the
Solar Electric Light Fund (SELF)
are joining forces to bring solar electricity
to South Africa.

Four million families in rural South Africa still have no electricity. They use kerosene and dry cell batteries for lighting and radios. Instead of waiting for the grid tomorrow, which may never come, we can hook them up to the sun TODAY!

Small PV systems can bring light and electricity to a home for only \$500. While families can't pay this up front, they can pay over several years if given credit. Rural families already pay ten dollars a month for kerosene and dry cell batteries. SELF, a non-profit charitable organization, has been providing rural credit for solar energy in Africa and Asia since 1990. But without seed funds to help communities purchase their first solar home systems, we can't provide SELF-help.

We are asking *Home Power* readers to start a **Solar Seed Fund**. SELF will provide all the overhead, including training and installation. Contributions from *HP* readers will purchase PV systems that families will pay for over 3 years. Income from installment payments will be recycled by a community-based revolving credit fund to provide loans for more systems. **Help bring Power to the People!**



Contribution Levels

- \$10
- \$50
- \$100
- \$500 (buys one home system for one family—donor will receive photograph of family with PV installation.)
*Any amount accepted.
All tax-deductible.*

Send contributions to:



Solar Electric Light Fund
1734 20th Street, NW
Washington, DC 20009

Info: 202-234-7265 Fax: 202-328-9512

Internet: solarlight@self.org

**Now that they have political independence,
we can help lead South Africans to
ENERGY independence.**



The EV-olution of Phoenix Racing

Above: Universities competed in the open-wheel Formula Lightning chassis.

Shari Prange

©1996 Shari Prange

Over the next few issues, we're going to take a look at electric car racing, in all its various forms. For now, let's take a look at one particular race, past and present.

This year marks the sixth for electric car racing in Phoenix. As the GM Impact pace car leads the field around the track, it seems like a good time to look back at the race as it has evolved through the years.

It began in 1991 as the Solar & Electric 500 at Phoenix International Raceway (PIR), conducted by the Solar Electric Racing Association (SERA). The following year Arizona Public Service (APS) came on board as the title sponsor. Two years ago it became the APS Electrics conducted by Electric Vehicle Technology Competitions (EVTC) at Firebird Raceway in Phoenix.

Different time, different place

The most obvious change is the track. The one mile oval at PIR really needs average speeds in the three digits to provide exciting racing. Though some EVs broke 100 mph briefly, average speeds were in the 50 to 60 mph range. On the road track at Firebird, the average speeds are the same, but the long, fast straight followed by tight turns creates more changes in speed, more passing, and a more exciting spectacle.

For anyone who remembers the first sweltering years, the change in date is welcome. The first races were run in late April in 100°+ temperatures. This year's race ran in early March in the comfortable 70s.

In the early years events routinely started late. EVTC has instituted strict rules about getting the cars to the "pre-grid" area resulting in punctual starts.

Solar out, Electrathon in

Another obvious change is that "solar" has vanished from both the title and the field. This is not surprising. The solar racers were designed for cross country distance runs at steady speeds in the 40 mph range.

Instead, starting this year, the event includes Electrathons. These tiny low-voltage racers aren't any faster than solar cars, but they are much smaller and more agile. They are able to battle for position more sharply and they look faster on the track. Two dozen Electrathon racers entered from all over the U.S. and Canada, setting a U.S. record for the largest field on a track. Two Vancouver teams flew to Phoenix, shipping their cars as "excess baggage."

The cars competed in four classes that shared the track: High School Standard (won by Lake Orion, MI), College Standard (Citrus College, CA), Open Standard (David Cloud, WA), and Open Experimental (Team New England, MA, the only entry in the class). Finish position was determined by combined laps from two one-hour races.



Above: The ESR-1 from Electric Sports Racing demonstrated as a potential model for a closed-wheel class.



Above: This scratch-built car from the University of Idaho won the Hybrid race.



Above: One of two electric karts from England that provided a lively demonstration.

In addition, four teams (Lake Orion, Mark Murphy, Clark Beasley, and David Cloud) shared the honor of a track record with 31 laps in a single hour, listed in the order they finished.

High schools

The high school class is still the mainstay of the event with three dozen schools participating. These conversions are limited by the original gross vehicle weight and 96 Volts maximum of lead acid batteries.

Enthusiasm ran high as teams competed in numerous categories: acceleration (won by Port Townsend, WA), oral presentations (Central Shenandoah, VA), design (Northampton-East, NC), braking and handling (Shadow Mountain, AZ), pit stops (Canyon Del Oro, AZ), and range (Shadow Mountain, AZ). Port Townsend, WA, was the overall winner.

The kids pushed hard. At least one spun out dramatically. There was even a minor collision but there were no damages a little body work couldn't repair.

The range competition was run with a pace car to ensure realistic performance. It circled the track at a set pace throughout the event. Any car that fell back and was passed by it was eliminated.

In addition to the combined categories, the schools ran heat races, a feature, and a semi-feature. Since there were so many schools they were split into two groups for heat racing. Prizes were awarded separately in each group with Northampton-East, NC and Palo Verde Magnet, AZ taking top honors.

The feature race included the top twelve finishers from each heat race, plus three "promoter's choice" cars, which were the next three finishers in the two heat race groups combined. The feature winner was Port Townsend, WA.

The eight cars not included in the feature race ran separately in a semi-feature which was won by Window Rock, AZ. This school is a repeat competitor, short on cash but long on enthusiasm. Their win was well deserved.

Universities

Another class that did not exist originally is the University Spec class for university teams using the Formula Lightning open-wheel racing chassis. Qualifying lap speeds ranged from 59 to 68 mph among eight teams.

These cars varied widely in voltage and components. However, all but one used lead acid batteries and most included a transmission. The cars had a lot of problems during qualifying. The paddock was a hive of activity as teams modified, repaired, or even completed their cars.

Three other open-wheel cars raced at the same time in the Formula E class. They were not classified as University Spec because they did not use a Lightning chassis or were not with a university.

In the 23 lap heat race, Ohio State University won the spec class and a Brawner Motorsports car took the Formula E and overall open-wheel first place.

The 44 lap feature race included quick battery changes. These still rely largely on muscular young bodies, sort of like synchronized weight lifters. Again, the Brawner car finished first in class and overall, and Ohio State took first in the spec class.

The Embry Riddle Formula E team seemed to have more than their share of troubles. First, a promised controller failed to materialize so they missed qualifying. They borrowed a controller then had transmission problems that kept them out of the Saturday race. At one point, they had one speed forward and four in reverse. Finally, they began to button-up the repaired car when their battery pack shorted out with a loud pop, destroying some of their batteries. One student remarked that perhaps they should change the car's number from 13 to something luckier.

Finally, they did manage to run fourteen laps in Sunday's race before more problems sidelined them again. Back to the drawing board.

Hybrids

The hybrid class, once a large high school class, has dwindled to three entries. The University of Idaho car, built from the ground up, won over a GM-sponsored Saturn and an Interstate Batteries Cobra.

Drags

Another recent addition to EV racing is the drag race. Entries competed in several categories: high school (won by Port Townsend, WA), race car (Ohio State), stock up to 144 Volts (Current Technology, NM), up to 288 Volts (Street Wires, OR), over 288 Volts (Wilde Evolutions, AZ), and a kart class won by a kart shipped over and run by the Japan EV Club.

This short but flashy event, complete with smoking tires, adds an appeal that EV races sometimes lack.

Stocks

The Stock Car category was divided into Street and Super classes which raced together. Super cars were intended to be professionally prepared, have corporate sponsorship, and could use exotic batteries. The Street class was open to amateur conversions using lead acid batteries. In fact, only the Aerovironment car used exotic (nickel metal hydride) batteries.

The Saturday 23 lap heat race started with a bang—



Above: The Salt River Project Probe, driven by Tom Sneva, qualified fastest in class, but finished second in both races.



Above: Gary Jackson, of Little Guy Racing, finished second in both Street Stock races, beating out six other cars with higher voltage.



Above: Electrathon racers battle for position on the front straight



Above: This beautiful car from Lake Orion High School won the second Electrathon race.

literally. The Wilde Evolutions Taurus went into the first turn with more speed than control. The cold tires lost traction. The Street-class Taurus spun and left the Super-class Salt River Project Probe with no place to go but into the Taurus. Both cars suffered some body damage but were able to continue.

Wilde's car was one of a half dozen that were forced to drop out later in the race without finishing. The DM3 Karmann Ghia lost a wheel on the last turn, and the AMFAB car broke an axle, but neither caused a problem on the track.

Difference of opinion

Perhaps the most dramatic maneuvering occurred in the official's tower. As the Stock heat race neared its final laps, the Cloud/Gabriel Colt, which had been listed until then in the Super class, was suddenly announced

as a Street car. This was an important change because it moved the Colt from second place in Super to first in Street—and moved Mary Ann Chapman of the We're It Porsche from first into second in Street.

Earlier in the race, Mary Ann had radioed her crew to ask which class the Colt was in, and she was told (correctly according to all distributed lists) that it was in the Super class. She said she could have passed it but chose to conserve her energy and focus on her own class instead. When the announced classification suddenly changed, it was too late.

Although the two teams presented a joint request to EVTC to declare a tied first place in Street with the prize money split evenly, the official results showed David Swan's Saturn first in the Super class with the Cloud/Gabriel Colt first in the Street Class. EVTC's

Below: A GM Impact served as pace car for the races.



official response was that the Colt was Street from the beginning and that the printed lists and announcements to the contrary were merely the result of a typo.

There were strong feelings in the We're It camp that they had suffered from basing their strategy on faulty information issued by EVTC. In similar SCCA (Sports Car Club of America) situations where multiple classes share the race track, it is not unusual for a car to forgo the risks of passing another car from a different class since they are not direct competitors. It was unfortunate that some official's typo went uncorrected long enough to cast an ugly pall over the finish for both teams.

More isn't always better

It was interesting to note that more volts did not necessarily equal more speed. The University Spec and Formula E cars ranged from 144 to 372 Volts. The two Stock classes ranged from 102 to 336 Volts. In neither group was the car with the most voltage the top finisher. In the University Spec/Formula E group, high and low voltages were scattered throughout the finish positions. The Super Stock winner had only 160 Volts. In the Street Stock class, the car with the lowest voltage (Little Guy Racing, CA) took second place over six higher voltage cars.

The lesson here is that a successful race car is a complex system, and a simplistic "bigger is better" attitude seldom wins.

Demos

There were a few demonstrations given by cars for which there were no racing classes. These included two irresistible electric go-karts from England that zipped around the course with 60 mph speeds. They looked like more fun than almost anything legal.

Demos were also given by two closed-wheel purpose-built race cars, one from Brawner Motorsports and one from Electric Sports Racing. The ESR-1 from Electric Sports Racing is a prototype for a proposed spec class of electric race cars similar in concept to the Formula Lightning class. Its speeds were competitive with the fastest Lightnings.

Changes in latitude, changes in attitude

There have been other changes, some so subtle they're not immediately apparent. In the early years, Solectria and DEMI were major forces at Phoenix. Now they don't even attend. There was little participation by component manufacturers or suppliers. The display area was largely filled with environmental displays.

The spectator attendance, however, is much the same as ever—scant, except for busloads of kids. In contrast, the biennial SEER event, miles from any major population center, has drawn two to three times as

many spectators. This is not surprising, since the Phoenix race is one of the best kept secrets outside the EV community. The general public around Phoenix was overwhelmingly unaware that the race existed—even among staff at the race headquarters hotel.

For the first couple of years the race was heavily salted with professional race drivers. Billy Roe and Tom Sneva are the only "names" who remain involved and there has not been any influx of mainstream racers.

This also is not surprising. Racers accustomed to the friendly efficiency of organizations such as the SCCA are put off by procedures designed to hinder them at every turn, as well as an adversarial attitude from much of the staff. A two-hour check-in, even after pre-registering by mail, and "pit bull" gate guards that would barely allow racers to drop off tools in the paddock started the weekend with a sour taste that lingered.

The next step

How will the Phoenix race evolve from here? The school portion of the event is strong and could be improved with more technical support to the schools in the early stages of construction. The stock car event will probably continue to draw hobbyists eager to race at any opportunity.

But if EVTC wants to move into the big time, it will have to make some changes. Sponsorship and displays by manufacturers and suppliers depend on a sizeable audience and participation by serious racers. That will require substantially better promotion and exposure, especially in the Phoenix area, than the race has received so far.

To be taken seriously alongside mainstream racing, EVTC will have to match the professionalism and support that mainstream racers expect. Mainstream and EV racing will eventually commingle. Whether the mainstream crowd will move into EV racing or serious EV racers will simply graduate from Phoenix and take their cars to the SCCA remains to be seen. The national SCCA is currently taking a serious look at expanding to include EVs.

EV racing has come a long way from six years ago when club rallies were the only venues. Then, as much as its participants loved it, EV racing was still just a puddle full of minnows. Now it has grown to a small pond and the APS Electrics is the biggest fish in it. However, it is still a little-known novelty to the world at large. The evolution must continue. It's a big ocean out there.

Access

Author: Shari Prange, ElectroAutomotive, PO Box 1113, Felton, CA 95018 • 408-429-1989



NO HASSLE WIND POWER

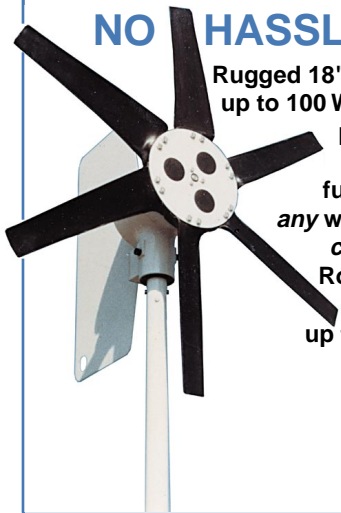

Rugged 18" blade Ampair 100 produces up to 100 Watts *continuously*, 24 Hours per day, at wind speeds from 8 to 100+ mph. No brakes or furling needed...guaranteed at any windspeed! Veteran of 3 years *continuous* Antarctic service. Roof mount is OK; pole mount is better. Put it up, hook it up to the batteries and forget it!

NO-HASSLE WATER POWER

If you have a reasonably fast running stream or tide nearby and 12" of water clear, Aquair UW Submersible Generator can produce 60 to 100 Watts *continuously*, up to 2.4 KWH per day. **NO TURBINES, NO DAMS, NO PIPES!** Water speed 5 mph (brisk walk) = 60W. 8 mph (slow jog) = 100W. Timber, rock, or natural venturi increases output.

12 or 24 VDC



Jack Rabbit Energy Systems
425 Fairfield Ave., Stamford, CT 06902
(203) 961-8133 • FAX (203) 358-9250

Renewable Energy on CD-ROM



For Alternative Energy Fans, Businesses, Researchers and Educators. PC/MAC/UNIX

Reports, Articles, Newsletters, Programs and Graphics on PVs, Wind, Hydro, Controls, EVs, Biofuels, Environment and Sustainable Systems

Article Text and Graphics from Home Power Magazine #1-#36

Includes: 250 Megabytes of Shareware and PD Software for Macintosh® and PC Compatibles

Home Power
PO Box 520
Ashland, OR 97520
916-475-0830



\$29⁰⁰
ppd

International Orders
Add \$3



For Credit Card Orders Call Home Power at 800-707-6585

CHEAP POWER
...Our low prices have turned the
PV industry upside down!
888-MR SOLAR
Toll Free 1-888-677-6527
SW4024 Trace Inverter \$2410
Similar Savings On All Items
More power to you...naturally!

Solar Pathfinder

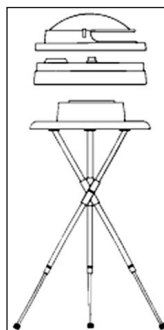

- ☀ Easy to Use
- ☀ Fast & Accurate
- ☀ Diagrams from 0-66° N & 0-49° S
- ☀ Pathfinder with metal case & tripod
\$216 (Handheld \$139)

25720 465 th Avenue, Dept HP
Hartford, SD 57033-6328
Phone & Fax: 605-528-6473
Internet e-mail: solarpf@aol.com



Electricity From The Wind & Sun



Utility Intertie Systems. (The 1st in the UK)

Stand Alone
& Remote
Home
Systems

UK
Distributors
for Home
Power
Magazine



11 years experience; our office, showroom, and workshop are wind & solar-powered.

Marlec, Wind Baron, Proven, Bergey and Vergnet wind turbines; Siemens, BP Solar and Solarex PVs; Powerstar, Trace, ASP sine wave and SMA utility intertie inverters; Oldham and Exide batteries. Also: Wattsun Trackers, APT Powercenters, ShurFlo pumps, low voltage lights, appliances and much more.



Wind & Sun

The Howe, Watlington
Oxford, OX9 5EX
United Kingdom

TEL. (44)-1491-613859

FAX (44)-1491-614164



Send for our Design
Guide & Catalogue:
Price £5.00 in the
UK (add £1.00 for
overseas postage).

Why Gamble on
✓ Un-heard-of brands
✓ AbUSED modules
✓ "Economy"
lightweights

When you can own
the SIEMENS M-55?

DEALER COST

PLUS 10% on

Trace Inverters
(full sized)

Sun Frost Refrigerators

\$299

"Full Box"
\$289

ABRAHAM

Solar Equipment
124 Creekside Place
Pagosa Springs, CO 81147

1-800-222-7242

THE POWER BROKERS!™

ANANDA
POWER
CENTERS

NEW,
OVERSTOCK

Carrizo Gems! never seen the sun	\$4.45/watt
Aquastar 80 ^{LPS} water heater	\$635 \$519
High-end motors; 1/3 hp @ 24 volts	\$226 \$75
Trace DR1524 inverter/charger	\$895 \$719

Major Project? Ask about on-site service!



ENERGY OUTFITTERS Ltd. announces the all new M-3 Floating Submersible Pump

Applications: The M-3 was specifically designed to pump from surface water sources such as ponds, dams, canals, and streams. Common uses are livestock watering, stream protection, water catchment systems, and pond aeration.

Specifications:

Power Source: Solar P.V. Modules or Battery Pack
Pump Type: Floating Centrifugal
Motor: D.C. Permanent Magnet
Seal: Magnetic Coupling
Voltage: 12-17 Volts
Current: 5 Amps
Duty Cycle: Continuous
Submersible: Yes
Self-Priming: Yes
Serviceable: Yes

M-3 PUMP PERFORMANCE CHART Based on (1) 74 watt Siemens PC 4JF

PUMPING HEAD	FLOW RATE	POWER
Feet / Meters	GPM / LPM	Volts / Amps
3.3 / 1	7.5 / 28.6	16.0 / 4.7
6.6 / 2	6.5 / 24.5	16.0 / 4.5
9.8 / 3	6.0 / 22.7	16.0 / 4.3
13.1 / 4	5.1 / 19.5	16.0 / 4.1
16.4 / 5	4.3 / 16.3	16.0 / 3.9
19.7 / 6	3.8 / 14.5	16.5 / 3.7
23.0 / 7	2.5 / 9.5	16.5 / 3.3

Dealer
Inquiries
Invited

ENERGY OUTFITTERS Ltd.

Order: 800-GO-SOLAR Office: 541-592-6903 Fax: 541-592-6747
136 S Redwood Hwy., PO Box 1888, Cave Junction OR 97523
nrgoufit@cdsnet.net (watch for our new www site!)



Photo by Steve Crise

Above: Riding the rails provides spectacular scenery and a way to get away from the crowds for Steve Crise.

Michael Hackleman

©1996 Michael A. Hackleman

Imagine putting your bicycle on a road where you do not ride alongside cars. That's right, no traffic. You don't have to steer either. In fact, you could use your hands to hold a book instead of the handlebars. On this road, there are no potholes, stop lights, or parked cars. Even if you're in mountainous terrain, there are no steep grades, only a few degrees of up or down. You might be able to go 50 miles without seeing another human being. A fantasy? No, welcome to the world of rail biking.

The road is a railroad. An **abandoned** railroad. There are more than a hundred thousand miles of abandoned tracks in the USA alone. (Where? About 80,000 miles of them are detailed in Waldo Nielsen's *Right of Way: Guide to Abandoned Railroads*.)

The machine you're riding is a rail bike. It can be a simple bicycle positioned over one rail and fitted with rigging that extends to the other rail to provide support and balance.

Ideas and designs of rail bikes abound. The challenge is to use a design that will let you experience the joys of rail biking without the dangers inherent in the sport. Fortunately, there is a wealth of information to draw upon.

Rail biking is not new. Rail bikes date back over a hundred years.

"The rail bike was born out of need rather than as recreation," reports Bob Mellin, author of *Railbike; Cycling on Abandoned Railroads*. "In the 1800's,

workers on and around rail lines needed an inexpensive human-powered vehicle by which to travel on the tracks to perform various tasks.” The two-person, seesaw handcart came from this era. So did the rail bike.

You can't buy a rail bike. People who use them think this is a good idea. Anyone who makes the effort to research, design, and construct a rail bike is not likely to risk collision with a train, trespass, or seizure of the rail bike through impulsive use of accessible track. Rail bikers want to improve their standing with railroad owners (who, at this time, see no merit in rail bikes) to legitimize the sport and gain access to track that is used infrequently.

Bob Mellin elaborates, “Railroad tracks—even abandoned—are private property and trespassing is illegal.” There are other hazards than trying to share a track with a train, always a no-win situation. “Some of the so-called rail bikes are very unstable and spills are common. Falling off a cycle onto a roadbed of wooden crossties, gravel ballast, and steel rails, usually in an isolated location, is courting very serious injury. Rights of way which are no longer used for rail traffic are not maintained. A cyclist may well encounter broken rails, washouts, rock slides, or other debris, even deteriorating or collapsed bridges and tunnels.”

On the positive side, rail bikers report gentle grades, a glassy smooth and quiet ride, hands-free operation, abundant wildlife, pastoral landscapes, clean air, and a feeling of adventure with each outing.



Photo by Bob Mellin

Above: Son Joe and daughter Haley ride the rails with Bob Mellin, author of *Railbike—Cycling On Abandoned Railroads*.

Below: 70 miles north of Ely, Nevada railcyclist Richard Smart pauses on a 150 mile cross-desert adventure.



Photo by Richard Smart

After devouring the information—history, designs, and rail biking stories—in Mellin’s book and newsletter (a benefit of joining RailBike International), I contacted Bob to ask permission to reprint some of the color photos in his book for HP readers. He agreed. I’m glad he did.

Access

Michael Hackleman, PO Box 327, Willits, CA 95490 • Internet Email: michael.hackleman@homepower.org

Railbike International, a clearinghouse for books like *RailBike: Cycling on Abandoned Railroads*, (Bob Mellin, 136 pages, \$17), *Right of Way: Guide to Abandoned Railroads* (Waldo Nielsen, \$20), and many other references, plans, and parts.

11 Library Place, San Anselmo, CA 94960
415-453-8886 • Fax: 415-453-8888
e-mail: railbikes@aol.com
Site: <http://home.aol.com/RAILBIKES>



Right: Richard Smart and daughter are accompanied by the family rail-dog “Butch” on an abandoned line near Cataldo Mission, Idaho.

Below: Railrider Dennis Bartlett (blue shirt) meets handcar pumper Steve Lansing at a crossing in Southern California’s desert.



Photo by Richard Smart



Photo by Steve Crise

LOWEST COST ELECTRIC BIKING & INDOOR FITNESS

with

EROS

(KITS AND SYSTEMS)

SILENT, FUN ELECTRICALLY ASSISTED BIKING AND INDOOR EXERCISE CAN BE YOURS FOR AS LITTLE AS \$199.00

FEATURES

- 10 minute installation
- Full Time regeneration (makes motor into generator when coasting)
- Light weight (12.5 lbs)
- Permanent magnet motor
- Sealed battery
- Sealed power switch
- Lifetime drive roller



SPECIFICATIONS

- 14 mph no pedal speed max.
- 12.5 lbs total system weight
- 300 watt motor (permanent magnet)
- Sealed AGM Battery w/1 yr Warranty

Dealer Inquiries Invited

OMNI INSTRUMENTS: 707-765-6992 • 937-0603

POB 96, Albion, CA 95410

Web Site: <http://www.mcn.org/a/omni>

Coming Soon!... the most exciting & affordable electric bike, the XRT 1-2 "Chopper"

FOOLS CROW CYCLES

camera ready b/w

3.5 wide

2.5 high

Solar Village Institute, Inc.

Solar, Wind & Hydro North Carolina Installer

Chris & Lynne Carter
"Living the Lifestyle"

Be your own Power Boss!
Call for your site analysis
We have the tools and experience



(910) 376-9530

5840 Jewell Road
Graham, NC 27253



*Stella,
the Celestial Fairy,
says...*

*"There's no magic
to keeping your
Home Power
subscription current.
Just read
your mailing label!"*

Confessions of a Battery Abuser

Anonymous

The night was dark and stormy. The rain pelted the skylights and flooded down the gutters while the wind howled menacingly through the trees and around the house, shaking the windows and chimney. The neighborhood was dark and no lights could be seen for miles around. The few radio stations that were still on the air reported that the utility power was out in the entire southern half of the state.

Fortunately, this home was powered with a photovoltaic renewable energy system with a back-up generator. It had been cloudy for several days preceding the storm and the generator had automatically come on to recharge the batteries the day before. The battery bank was sized to provide four days of cloudy operation.

It was near midnight when, surprisingly, the generator started up again. A quick check of the voltmeter revealed that the batteries were near the bottom of their charge. What! So soon? A question was raised. Was the generator filled with gasoline the day before? No one remembered, and no one wanted to go out and check the fuel gauge in the raging storm.

While everyone was trying to remember whether the generator had been topped up with gas, a quick check was made of the house loads. Was something on that shouldn't be or was there some kind of fault that caused the batteries to be drained so quickly? No, everything appeared normal. There were no new hidden loads and the system ammeter showed that the existing connected loads were drawing only their low, energy-conserving amounts of current.

At this point, the lights dimmed a few times and went out as the generator slowly ran out of fuel and quit. A search with flashlights for the gasoline can found that it was empty. A quick trip to the gas station was aborted when everyone realized that, with the utility electrical outage, there was no power for the gas pumps.

Candles were lit and everyone settled down to try to figure out why the batteries had not kept their charge.

They were, after all, top-of-the-line golf-cart batteries that were only five years old.

Had they run dry and someone forgot to check that water was always over the plates? Well, it seems that that might have happened a couple of times every summer. And during the last year or so, it was getting necessary to check them every three or four weeks to add water. More water was always needed in the upper set of eight batteries on a 24-inch high shelf than was needed in the lower set of eight on the floor.

Did the temperature compensated charge controller work properly? Well, the home-brew charge controller didn't have a temperature compensation device; the voltage set points were adjusted by the seat-of-the-pants method based on the season. The battery charger in the inverter had a temperature sensor, but somehow it had come away from close contact with the batteries. Anyway, it couldn't be too important since only one sensor monitored the temperature of the batteries and they were at two different locations.

Was the temperature too high or too low in the garage where the batteries were mounted? Well, let's see - it must get about 110°F on hot summer days in there and down to about 20°F on cold winter days. Maybe it was a little extreme for batteries that like to stay at 80°F.

Was the three-stage charger working properly? Well, no! This charge controller had only a single set point that held the batteries at that voltage. Did someone remember to lower the set point during the four-week long vacation every summer? Was that really needed? The set point was only a volt or so above the gassing voltage to get those batteries good and stirred up every cycle. But, during the summer vacation, the house loads were reduced to zip, and gee, the batteries sure did need a lot of water when the family returned home.

How about the battery installation? Did every cell get an equal share of current, voltage, temperature? The eight batteries on the floor had a one-foot longer cable than the set on the top shelf. No Z-style plumbing-type wiring was used; after all 2/0 cable was used between cells and those automotive-style posts and clamp-on terminals were plenty hefty. It was also a little cooler all the time near the floor than it was on the shelf.

Were the cable clamps always tight on the terminals and the clamps always tight on the cables? Now, that's an interesting question. At times, when the voltmeter was used to measure the voltage drops in the cable, some cables measured 12 millivolts and some measured 150 millivolts - boy, some of those terminals were warm! Isn't that normal?

When the batteries were equalized every month or so,

were the Hydrocap vents removed and the regular battery caps reinstalled? Remove the Hydrocaps every time - heck, there are 48 of them! Maybe they were removed once a year. Anyway, no one wanted all that messy acid dripping out of them.

With nothing more that could be checked that night, everyone went to bed to the sounds of the storm still raging outside.

The next day, the utility managed to restore some power and gasoline could be purchased. The generator was refilled and started to recharge the batteries. The sun came out and the PV array also helped to recharge the batteries.

Measurements on the battery bank, one string at a time, revealed that the eight batteries on the top shelf were totally dead and beyond salvation. The eight batteries on the floor had a little life, very little, and were used to hold the system together until new batteries could be purchased, delivered, and installed. Numerous battery clamps on both the cable end and battery-post end were found to be loose.

Although heavy cables had been used, the slightly longer cable and cooler temperatures for the eight batteries on the floor had given them a longer life. The abuse of the system and lack of proper maintenance had allowed the eight batteries on the top shelf, operating at higher temperatures and higher voltages, to come to the end of their cycle life prematurely.

Proper installation and proper maintenance would have yielded several more years of life from these batteries.

A New Leaf Was Turned Over

A decision was made to replace the nearly dead golf-cart batteries with a new set of batteries that would be installed properly and maintained well.

In a few weeks, a truck delivered a ton of new Trojan L16 batteries (16 at 133 pounds each).

The walls and ceiling of the garage, where the battery bank was installed, were insulated to moderate the seasonal temperature swings. The garage door was also insulated.

The generator was converted to dual-fuel operation (natural gas and gasoline) with propane as a third fuel option. Natural gas pumping stations have back-up generators (run on natural gas - what else?) to deal with power outages. Propane can be stored for a long time.

The old dual-layer shelving was ripped out. A pad of two inches of Styrofoam, wrapped with polyethylene film, was placed on the garage floor to moderate the temperature of the battery bank.

After looking through numerous container catalogs, a trip to the local Walmart yielded some very heavy-duty polyethylene containers. These containers, used as tool boxes in the back of pickup trucks, had lockable lids. With a little modification they were large enough to hold four L-16 batteries complete with Hydrocap vents, and they had plenty of room left over for the wiring. Four of them were set on the insulating pad.

Two-inch electrical PVC conduit was used between each of the containers and between one container and the power center. The conduits were connected to each end of the containers several inches below the tops of the batteries to prevent hydrogen gas from getting into the conduit and power center. Small holes were drilled in the tops of the containers to allow hydrogen gas to escape.

A call to a cable distributor in the next state placed 100 feet of the flexible 2/0 AWG USE/RHW/RHH cable on order for delivery in a week.

A visit to a local electrical supply house resulted in the purchase of two large, insulated power distribution terminal blocks. These terminal blocks had six large holes capable of connecting up to 250 kcmil cables.

The batteries were placed in the containers, and the distance between all of the terminals was carefully measured. Since the batteries came with type L terminals (posts with two flat sides and a bolt hole), it was decided that copper bar stock would be the cheapest and best way to connect the batteries in series. A metal supply outlet in a nearby city had some copper bar stock in 1/8-inch by one-inch by 12-foot lengths for a reasonable price-cheaper than 2/0 AWG cable and crimp-on terminals.

The Trace 4024 sinewave inverter in the system dictated that two paralleled 2/0 AWG cables be run from the battery bank to the power center. Four equal lengths of cable were cut - two for the positive conductor and two for the negative conductor. At one end of these cables, large lugs were crimped on using a heavy-duty crimper about the size of a large bolt cutter. No solder was used on these crimped terminals, but they were sprayed with an anti-corrosion fluid and covered with heat-shrink tubing. The ends with the terminals were connected to the main battery disconnect switch for the power center - two to the positive terminal and two to the negative terminal.

The other ends of these cables were stripped, run to a location in the center of the battery bank, and then connected to the two large power distribution blocks. From the power distribution blocks, equal lengths of 2/0 cable were run to the ends of the four strings of batteries. Large terminals were crimped on the ends of

these cables, and after spraying and covering them with heat shrink tubing, they were attached to the battery terminals.

The copper bar stock (equal in area to 2/0 cable) was cut in nine-inch lengths, drilled for bolts, covered with heat string tubing, and connected between the four batteries in each of the four series strings. All exposed battery posts and terminals and the ends of the copper bars were sprayed with anti-corrosion fluid.

With this wiring configuration, the lengths of cable between the power center and each string of batteries were identical. The positive and negative cables were also equal in length. To further assure that voltages and currents divide equally across the batteries on both charge and discharge cycles, 8 AWG USE type cables were cross connected between the series strings at the 6, 12, and 18-volt levels.

The use of crimp-on terminals was held to a minimum and those that were used, were crimped with a very large, heavy-duty, utility-grade crimper. Terminal blocks were designed to carry several times the current levels required by this system. The use of the proper cables and cable attachment methods kept voltage drops and power losses to an absolute minimum.

Since most batteries are shipped with an initial capacity of only 85% of the design capacity, the batteries were cycled to about 50% state of charge several times and recharged with the generator to bring them to full capacity.

New Hydrocap vents were installed on the batteries. A new Trace C40 charge controller with a three-stage charge control process was installed. The bulk charge voltage was set just above the gassing voltage (28.6 volts at 77°F) at about 29 volts. The float charge voltage was set below gassing at about 26.5 volts. These settings would get the battery up to near full charge every day that sufficient sunlight was available to offset the loads. During long vacations with no loads, the system would keep the batteries fully charged and below the gassing voltage for minimum water usage and long life.

Battery temperature sensors for both the inverter and the charge controller were firmly attached to the side of a battery near the center of the battery bank.

A rubber apron, face shield, rubber gloves, goggles, and old clothes were stored in the garage for use whenever service would be required on the battery bank.

A maintenance schedule was set up with a log book. Once a month, the Hydrocap vents would be removed and the original battery caps reinstalled. Either the house loads would be reduced or the generator used to

bring every cell in the battery bank to an equal and full charge. This would be done by setting the charge controller or the inverter set points to hold the battery bank at about 29.5-30 volts which would cause the batteries to gently bubble as they generated hydrogen gas. This would stir the electrolyte to avoid stratification and remove any large lead-sulfate crystals that might have formed in the batteries. The batteries would be held at this voltage for three to four hours or until the specific gravity of each cell reached a maximum and was the same for all cells.

Every six months, all of the terminals would be checked for tightness. Voltage drop measurements across all cables and terminals under high charge or discharge currents would be used to identify items that required maintenance. Insulated wrenches would be used to tighten any loose terminals.

In summary, batteries can have very long, productive lives. They must, however, be treated with respect and kindness. A proper and safe installation is an absolute necessity. The correct selection, installation, and adjustment of cables, terminals, and charge controllers will ensure proper operation and long life. Batteries cannot be installed and forgotten in any system. Continued care and feeding is required.

No abuse makes for happy, long-lived batteries with no unexpected blackouts.

Access

Battery Boxes: Packer 45 Storage Chest by Delta Consolidated Industries • PO Box 41209, Raleigh, NC 27629 • UPC 4341990254 • Available at or through Walmart stores.

Insulated Terminal Blocks: Polaris IPLD series by NSI Industries • PO Box 561596, Charlotte, NC 28256 • 800-321-5847

Flexible Cables: Type USE/RHH/RHW • Anixter part number 3BF xxxx • Anixter Brothers • 800-323-8166 (for large quantities) or PV Distributor

Anti-corrosion Fluid: Permatex Battery Terminal Spray • Available from auto parts stores

The Ex Battery Abuser may be contacted at SWTDI/NMSU • POB 30001/Dept. 3 SOLAR • Las Cruces, NM 88003 • 505-646-6105



BACKWOODS SOLAR ELECTRIC SYSTEMS

For an Earth Restored and a World at Peace... Independent Electric Power Systems for the Remote Home—Solar Electric, Wind, Hydro

We are a family business, living with our products for over 15 years, and offer the knowledge to help you set up your energy system. Free Consultation. Questions are personally answered.

Our catalog includes a planning guide to help you understand how to put your energy system together - its applications and sizing. We offer lower than usual prices on *Kyocera*, *Solarex*, and *Siemens* modules and *Kohler* generators.

Our *Trace* inverters include free battery cables. We carry *Sun Frost* and *Nova Kool* refrigerators, specialized appliances and lighting, and a range of meters and controls: *Heliotrope*, *SCI*, *Ananda*, *TriMetric*, and our own *Backwoods* control boxes.

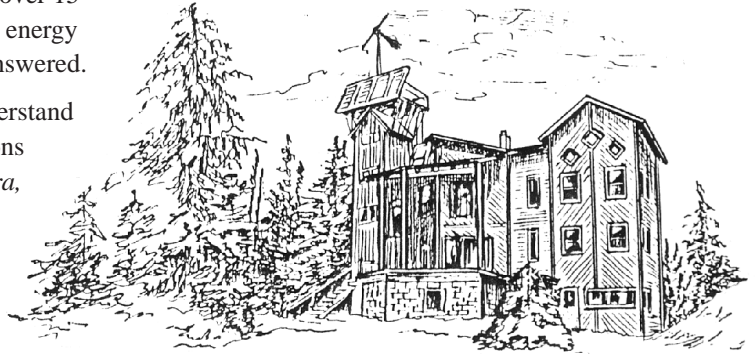

Our \$3. Catalog/planning guide is FREE to *Home Power* readers.

We accept VISA and MasterCard



Most items in stock for immediate shipment.

Steve & Elizabeth Willey • 8530-HP Rapid Lightning Creek Road • Sandpoint, Idaho 83864 • (208) 263-4290

THE SOLAR BOILER™

State-of-the-Art Solar Water Heater

- PV powered, drain-back system
- Uses no ac electricity or controls
- Pre-assembled pump/heat exchanger module
- No pressurization/evacuation
- One day installation; no special tools required
- 10-year warranty all major parts

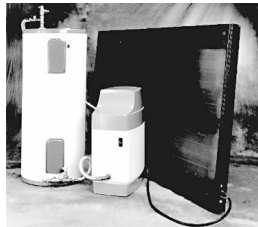

Call today for complete information on our ready to install solar thermal, pool heating, and solar electric home power systems. Dealer inquiries welcome.

Solar Works, Inc.

64 Main Street, Montpelier, VT 05602
Tel: (802) 223-7804 Fax: (802) 223-8980

Made in USA

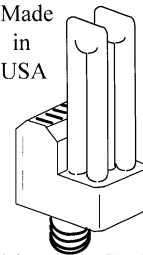

Glory to God

5825 N Calle Tiburon,
Tucson, Az 85704-1725

Voice and FAX
(520)-293-0031



13W Single \$30
18W Quad \$37

14W Quad \$34
26W Quad \$45

12V • 24V • 36V • 48V DC or AC

10000 hour non-replaceable bulb included.
Quantity pricing up to 50%. Hi/Lo Dimming.



Low Cost Wind Power

Used & new wind generators / parts & PV modules

Propane Refrigerators – \$995

Trace SW4024 Sinewave inverter
with bent cabinet – \$1980

Selected DC compact fluorescent lights – \$29

\$4 Independent Power Catalog, \$5 Windmill Water

Pumper Catalog, \$3 Bulk Food Catalog,

\$6 GE Electric Garden Tractor Info Packet.

Kansas Wind Power, Dept HP54
13569-214th Road, Holton, KS 66436
"Since 1975" 913-364-4407

Powerhouse Paul's Stream Engines™ Small Scale Water Power Equipment

FIRST TO MARKET:

- Small Turgo Turbines –
- Low Head High Flow Machines –
- Induction Generators –
- Brushless Alternators –

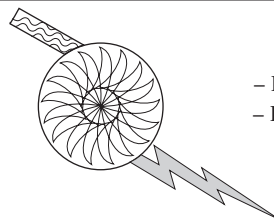

IN BUSINESS SINCE 1980

- operates on heads of 4 feet to over 400
- Battery voltage or high voltage for long distances
- Pelton and turgo turbines runners sold separately

ENERGY SYSTEMS & DESIGN

P.O. Box 1557, Sussex, N.B., Canada E0E 1P0
506-433-3151



Things that Work!
tested by *Home Power*

Things that Work!

ZANE International's Variable Speed Fan Control

Tested by Michael Welch

My question was, "Can I find a good, inexpensive off-the-shelf solution for controlling the speed and direction of my new 12 Volt DC ceiling fan?"

I didn't even know where to begin to look for something like this and hadn't even begun my search when I saw a product release notice from Zane International in *Solar Today* magazine for their Variable Speed Fan Control.

The notice promised adjustment over the full range of fan speeds and a three position switch for forward-off-reverse. Just what I was looking for! I ordered it directly from the manufacturer.

It arrived safely packaged in bubble wrap and a small box. The instructions that came with it were very well done making installation a snap.

I was very pleased with the way the unit is set up. It is compact and mounted on the back side of a standard sized switch-type plate designed to be installed into a regular single ganged interior electrical box. The components are solidly mounted using the nuts holding the knob shaft and direction switch. From the back you can see that epoxy and cable clamps keep the components and wire solidly in place.

From the front all you see is the speed control knob and the fan direction toggle switch. Very clean.

It will work with ceiling or other fan motors designed for up to 2 Amps, but has a user accessible fuse just in case you forget. Some of the technology is proprietary and patented, although it was unclear as to which part was so. I was told that it uses a switching power supply and their publicity claims "capacitive silencing for noise free operation." That's the truth. I could find no interference from the unit in our tv, telephone, radio, or stereo system at any fan speed or direction. The company also claims a 97% efficiency, and while I have



no hard data, I don't doubt it. The ceiling fan with controller barely registers on my Amp meter.

The installation was very easy, even for my situation with #8 stranded wire going to and from the wall box to the fan. Zane provides crimp connectors on the 4 wires. With 4 #8 wires in my box, the squeeze was a little tight, but there was enough room to do the job.

All things considered, I like this product a lot. It comes in either ivory or dark brown, a choice of 12 V or 24 V

(nominally more expensive) models, and a 60 day limited warranty. Providing an additional off position on the direction switch allows the user to turn off and reverse the fan without losing the optimal speed setting they chose with the knob. Smart thinking.

Since I received my unit, Zane reports that their products have received UL listings. The ceiling fan controller can be purchased for about \$32 dollars from one of their distributors. Call them for a list of retailers that sell their products.

Zane also manufactures automatic light dimmers to keep light at constant levels regardless of ambient light levels, higher amperage motor speed controllers, and linear power supplies. We will be testing some of these in the future. The linear power supplies look very interesting as a way of getting 5 to 24 Volts out of a 24 Volt battery bank.

I found the answer to my question. The controller was installed two and a half years ago and has been performing flawlessly and as advertised ever since.

Access

Author and tested by Michael Welch, c/o Redwood Alliance, PO Box 293, Arcata, CA 95518 • 707-822-7884 • Internet Email: michael.welch@homepower.org • World Wide Web: <http://www.igc.apc.org/redwood>

Manufacturer: ZANE International, Inc, 510 Fruitvale Ct. #B, Grand Junction, CO 81504 • voice: 303-444-7226





RADIO

C. CRANE COMPANY

Things that Work!



Portable Power Pack
12 v- 7 AH Gell Cell

Complete with AC adapter, and lighter patch cord for charging.
INCLUDED: Magnetic Light, 12, 9, 6, & 3 volt DC/DC stepdown with universal plug tips, Female lighter plug output jack.

Special introductory price \$159.95
 Price includes shipping Made in USA

OPTIONAL: Solarex 10 watt panel with lighter splitter \$143.95.

AM/FM, SHORTWAVE, SCANNER RADIOS/ANTENNAS AND BOOKS

Please write or call for free catalog
558 10th Street, Fortuna CA 95540
1-800-522-TUNE (8863)

Satisfaction Guaranteed

At **Northwest Energy Storage** we've been serving you since 1990 with high quality affordable batteries. Now we would like to offer other quality Renewable Energy Products! Just to name a few...

**TRACE • EXELTECH • MORNINGSTAR • HELIOTROPE • E-METER
 SIEMENS • SOLAREX • KYOCERA PV Modules**

SUNRISE Solar Submersible (deep well pump) • **SHURFLO** Solar Submersible
SOLAHART A true solar hot water system installed in over 90 countries worldwide.

Introducing: the Hup Solar-One
 Deep Cycle lead-Acid Battery

- Optimized for Renewable Energy •
 - ISO 9000 Certified •
 - Computerized Patented Manufacturing •
 - Free Lead-Plated Copper Intercell Connectors •
- Free Shipping in 48 States*

Lineage 2000 Battery

- Save over 75% off the cost of New •
- Sale on Surplus 1994-95 Manuf. Dates**
\$1800 @ 12 Volt

While quantities Last

To order or receive information call:

1-800-718-8816 or (208) 263-6142

Northwest Energy Storage

10418 Hwy 95 North, Sandpoint ID 83864



SOLAR QUEST

Becker Electric
CSL #585741

Photovoltaic Panels Instead of Roofing

1-800-959-6354

Product Catalog
\$3.95

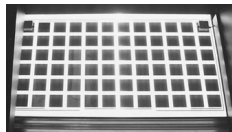

Complete Solar System Packages

SALES ☻ **INSTALLATION** ☻ **SERVICE**

28706 New School Rd., Nevada City CA 95959
Phone (916) 292-1725 Fax (916) 292-1321

The Perfect Solar House Shell !

Nature House®



Pre-Designed & Fabricated
Structural Insulated Panel Packages
Design-Engineering-Fabrication-Construction Assistance

Better Building Systems

563 Idaho Maryland Road, Grass Valley, CA 95945
(916) 477-8017

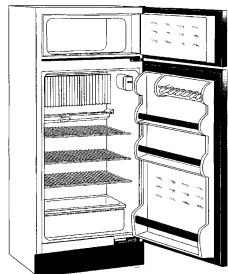

**Propane Refrigerator
DPR2260**

\$995.00

Plus Shipping

(800) GO-SOLAR (467-6527) nrgoufit@cdsnet.net
136 S. Redwood Hwy., P.O. Box 1888,
Cave Junction, OR 97523

Dealer
Inquiries
Invited

Danby®

"Good things come in small packages"

- 7.8 cu. ft. Capacity Refrigerator.
- Reversible Door Hinges.
- Door Liner has large, functional divisions, plus a molded Egg Rack.
- Tall Upper Shelf accommodates 1 & 2 gal Jugs.
- 3 Easy-glide Shelves and a Large Crisper.
- Battery Powered Refrigerator Light.
- Automatic Lighter (piezo-electric)
- Automatic Safety Valve.
- European Style Door with Recessed Handles.
- Refrigerator is AGA & CGA Approved.
- No Electricity Needed.



SOLAR INDUSTRY JOURNAL

camera ready

b&w

3.5 wide

4.85 high

America's Hardest-Working Country Magazine



"This magazine attends pickup trucks, chickens, tomatoes, sawmills, homeschooling, maple syruping—all the stuff you need to know to live a good, but not necessarily more simple, life in the country. Written by unpretentious folks who are living the life portrayed, It's an improvement on sixties efforts that tended to be unrealistic hype and dream. Already-there's and wannabes alike will find plenty of ideas and good information."

—The Millennium Whole Earth Catalog

Join the family of readers who are coming BACKHOME to basic, independent family living. Each quarterly issue is packed with clear, practical how-to information on gardening, recycling, home business, home energy, community action, family projects, home improvements, and much more!

Yes! I'll Try BACKHOME.

- Sample Issue \$5.00 postpaid
- One Year (4 Issues) \$17.97 (U.S. funds only)
- Two Years (8 issues) \$31.97

Satisfaction guaranteed.

Name _____
 Address _____
 City _____ State _____ Zip _____
 Enclosed is my Check Check Money order for \$ _____
 Charge my VISA Mastercard
 Acct. No. _____ Exp. Date _____
 Signature _____

BACKHOME Magazine • P.O. Box 70-HP • Hendersonville, NC 28793

TOLL FREE 1-800-992-2546

Things that Work! Thermal Art®



Things that Work!
tested by *Home Power*

tested by Richard Perez

I never thought that I would give the Thumbs Up! to an electric heater. Thermal Art electric heaters changed my mind. They are appropriate for use in home-sized renewable energy systems as well as on the grid.

What is Thermal Art?

Imagine a framed painting which conceals a highly effective, low intensity, electric heater. These Thermal Art heaters are powered by 120 vac and come in wattage sizes which are appropriate for home power systems—150 and 300 watts. The 150 watt models measures 24 inches by 15 inches, while the 300 watt models measures 24 inches by 31 inches.

Shipping and Documentation

The Thermal Art heater arrived here in good condition via UPS. It is rather heavy (our 150 watt models weighs 15 pounds) and packaged accordingly. The instructions are thorough and complete, covering everything from installation to usage. I had it on the wall and working within minutes of unpacking the painting (or should I say heater?).

Installing Thermal Art

The heater comes with a heavy steel wall bracket with a built-in level so the picture is straight and level when mounted on the wall. The only tools I used were a drill and screwdriver. The painting hangs securely to the bracket and all that remains is plugging the unit in to a standard 120 vac receptacle.

Heating with Thermal Art

I installed the heater in our office which is an add-on to our main building. This office is normally heated by warm air flowing through a doorway from our front room where the wood heater lives. This office has always been rather chilly on winter mornings even though it is insulated to R-19 in the walls and R-40 in the ceiling.

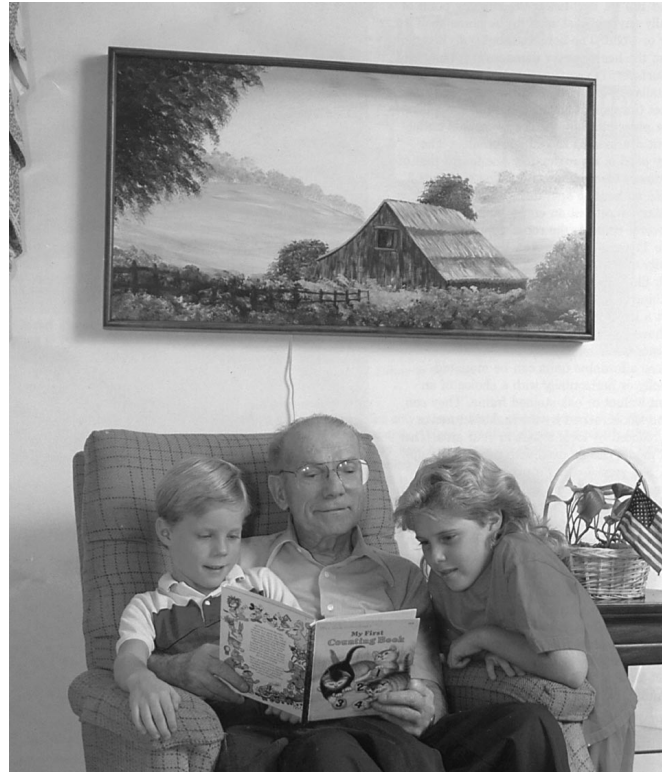

Above: Mearl Ellison, the inventor of Thermal Art, and one of his super-effective electric heaters.

Some mornings we have had to delay work until the office was warm enough to allow computer use (55°F). I mounted the Thermal Art Heater about four feet from the floor on the north wall. We have been using the heater on chilly mornings for about 18 months now.

The first thing we noticed was how evenly the heater warmed up the room. Instead of using high power and a fan to distribute the heat throughout the room as conventional electric heaters do, the Thermal Art heater uses low power and low intensity convection—no fan means lower energy consumption, no blowing dust, and no noise. I'd switch the heater on in the morning and within about two hours the office was toasty warm. The heater has a thermostat so that once the room comes up to the desired temperature, the heater shuts off until the temperature drops. There is a small neon indicator that indicates when the unit is on and heating.

At first I figured that we wouldn't be able to use the heater much because we are a stand-alone PV/wind system and electricity is a precious commodity hereabouts. I was wrong. During those sunny, cold, winter days, we have more than enough power to use this small 150 watt heater. I figure that 4 of our over 50 PV modules are required to power the heater. Essentially when the batteries are full and we have a surplus of power, we'd turn on the Thermal Art heater

Things that Work!

and back off on the wood stove. I could really get to love electric heat! No ashes, no chopping, no chainsaw, and free fuel deliveries daily! If we had a cold and windy night, I'd switch on the Thermal Art to use surplus energy from our Whisper 1000 wind generator and wake up to a warm office in the morning. I'm sure that many home power systems have periods of surplus energy. The Thermal Art heater is a good place to use this surplus during the winter.

For those on grid, Thermal Art offers room by room climate control at a fraction of the cost of central heating systems. Thermal Art is not only less expensive to buy and install, but also less expensive to run. The low intensity convection design does not dry air out and this means a more constant humidity within the room. No forced air also means less dust and perfect warm air circulation throughout the room. Anywhere you wish to heat electrically is the place to use Thermal Art. In addition to offices, bed rooms, and living rooms are good places. Those living in mobile homes, RVs or boats which are hooked up to 120 vac power will find Thermal Art particularly effective.

But is it Art? Or everyone is a critic.

Well, while I can slap the Fluke 87 Digital Multimeter on the heater (and yes it does really use only 150 watts), I cannot pass judgement on its artistic value. I've been told on several occasions that all my taste is in my mouth. The painting on our Thermal Art heater is of a woodland scene with a creek flowing down the middle. I thought it not bad and would muse about elves and trolls cavorting behind the trees and bushes. Our Art Director, Ben Root, allowed as how he'd seen better art in motel rooms. The Thermal Art heaters are available with hundreds of different paintings. If you are an art critic, then try the model that comes with a blank white acrylic coat and paint your own. You can also fasten magnetic cutouts to the surface of Thermal Art heaters. While paper attached with magnets to the heater will not burn (the surface temperature of the painting is only 135°F), the maker does not recommend this.

Bottom Line Time

The 150 watt Thermal Art heaters cost \$147 with a painting on it, and \$108 with a white face ready for you to paint. The 300 watt Thermal Art heaters cost \$175 with the painting of your choice, or \$150 ready for you to paint. All Thermal Art heaters are UL® and CSA approved and come with a ten year warranty. In terms of energy cost to operate, the Thermal Art is free for us since we only use it during periods of energy surplus. For an RE system, the only way to waste energy is to not use your surplus. In terms of operation on the grid, the 150 watt Thermal Art unit costs about one cent per hour to operate.

Thermal Art heaters are the most pleasant electric heaters I have ever seen. They don't dry out the air or recirculate the room's dust (and in our case cat hair). Thermal Art electric heaters are the only type effective enough to be useful in home-sized renewable energy systems. If you are on grid and using electricity for space heat, they will save you big bucks. Thumbs Up to Mearl Ellison and the Thermal Art Crew!

Access

Author: Richard Perez, c/o Home Power, PO Box 520, Ashland, OR 97520 • 916-475-3179 • Internet Email: richard.perez@homepower.org

Thermal Art's Maker: Thermal Art, Inc., 8828-30 Somerset Blvd, Paramount, CA 90723 • 800-628-4328 • 310-633-4328



SOLAR ELECTRIC INC
camera ready
b&w
3.5 wide
1.6 high

MAPLE STATE BATTERY

Lowest Prices

Panels • Controllers • Inverters
Servel & Sunfrost Refrigeration
Delivered Anywhere



Trojan

(802) 467-3662

Sutton, Vermont 05867

Inverters 1-800-245-1827

- 12V to 115v Inverter - 140w-200w peak @ \$49.50
- 12V to 115v Inverter - 300w-500w peak @ \$78.50
- 12V to 115v Inverter - 600w-1000w peak @ \$195.00
- 12V to 115v Inverter - 1500w-3000w peak @ \$440.00
- 115v Emergency Switchover Unit at 10 amps @ \$44.50
- 115v Emergency Switchover Unit at 20 amps @ \$56.00
- 12-24V Battery Isolator - 75 amps @ \$32.50
- 12-24V Battery Isolator - 125 amps @ \$44.50
- 12V Pumps 450 gph @ \$16.50 to 2500 gph @ \$72.00
- Computers Assembled to your spec. & Parts

A.C.I. PO Box 10463, Santa Ana, CA 92711

Shipping at UPS Rates

Things that Work!



Things that Work!
tested by *Home Power*

The TriField[®] EMF Meter

tested by Richard Perez

Have you ever wondered about the electromagnetic fields (EMFs) generated in your household? Are you getting dosed with harmful EMF radiation while using your computer or watching TV? Here is an accurate and inexpensive meter that will measure your exposure to EMFs.

It comes with the territory...

Electromagnetic fields are generated every time we use electric power. The intensity of the EMF is basically proportional to the amount of current flowing. AC magnetic fields surround all active 120 vac wiring. Common appliances such as television sets, computers, fluorescent lighting, and any device with an electric motor generate electromagnetic fields when they operate. These potentially dangerous fields are an inherent part of using electricity. See *Home Power* #23 (June/July 1991), pages 24–30 for a thorough article about the physics and possible health effects of low frequency ac magnetic fields. More recent health studies indicate that we should minimize our exposure to these fields. In order to do this, we must first be able to measure the fields in our homes, find the offending appliances, and correct the problems. Sort of a search and destroy mission with the EMF meter as our guide.

The TriField EMF Meter

The TriField is especially designed for usage in homes. It measures low frequency ac magnetic fields in two ranges: 0–3 milliGauss and 0–100 milliGauss. It also measures electric fields from 0–100 kilovolts per meter and radio/microwave fields from 0–1 milliwatts per

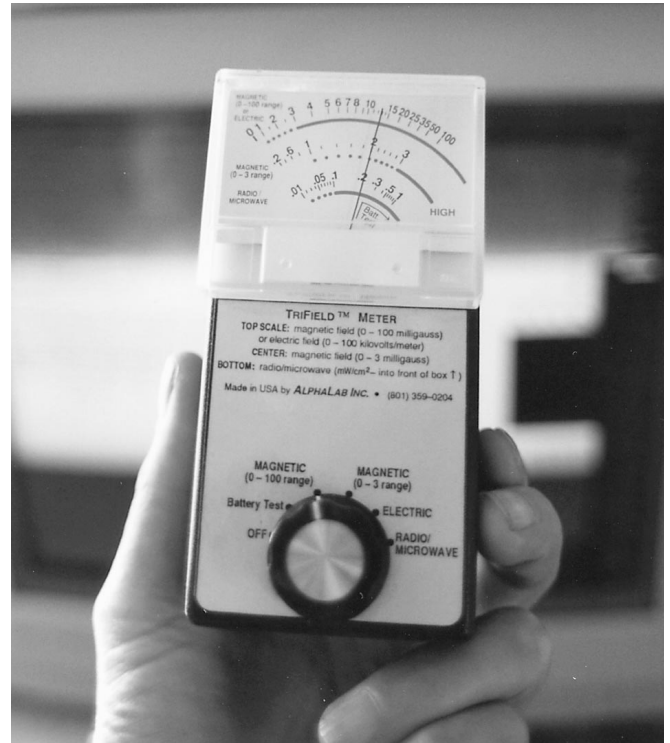

square centimeter. The TriField is able to measure all three types of potentially dangerous EMFs. The meter measures 5 inches by 2.5 inches by 2.4 inches and is hand held. It is powered by a 9 Volt transistor radio battery which lasts for about 50 hours of operation. There is a battery test function built into the meter so you don't get bogus readings because of a weak battery.

The TriField uses a 3-axis sensor arrangement that measures fields in a more average fashion than lab-type meters which use a directional pickup. This makes the TriField easier to use and the 3-axis setup more accurately measures the way that the human body intercepts these EMFs.

The TriField arrived here well packaged and with a very informative set of documentation. There is an operators manual which tells how to properly use the meter. There is also information about the health effects of EMF and how to easily reduce your family's exposure to EMF.

Operation of the TriField meter is simple. Select the field type to be measured and walk around the house until the meter starts reading in the red bands on its scale.

Hunting down EMFs at HP Central

Our place here on Agate Flat is both a fairly representative household and an electronic publishing office. We have most types of appliances used in

homes and offices. I have actually been using the TriField for over 14 months now and make all measurements regularly. I also sniff each new appliance as it arrives.

I found substantial magnetic fields surrounding our computer equipment, especially the large color CRT monitors. As I sit writing this (about two feet from the 21 inch CRT), I am being exposed to about 2 milliGauss. Directly on top of the CRT the magnetic field reaches 50 milliGauss. The fields surrounding the remainder of the computer gear were small. Since magnetic fields obey the inverse square law of radiation, the fields reduce quickly as you increase the distance from the source. The other equipment in the office (FAX, modems, telephones, etc.) produces only moderate fields (less than 3 milliGauss). We have an evaporative cooler with a large fan that cools the office on hot days. This "swamp" cooler produces a whopping ac magnetic field (over 100 milliGauss) within one foot of the cooler. Bottom line here is don't sleep in front of the cooler when it's working.

The situation in most of the household was not too bad. We found an intense (over 100 milliGauss) field within three feet of the microwave oven, but the oven tests fine (less than 0.1 milliWatts per sq. cm.) for microwave RF leakage. Our compact fluorescent lamps (Osram EL series on 120 vac) produced less than 1.5 milliGauss at a distance of 2.5 feet from the lamp. Both the house and office tested very clean for electric fields which is not surprising since we are a low-powered operation and use no voltage above 120 vac rms.

The strategy is to not spend very much time bathed by intense ac magnetic fields. Locate furniture (like your favorite chair and most especially any beds) in areas of the home that have low field levels. We measure background low frequency ac mag fields at less than 0.5 milliGauss outside of our buildings. Inside, the fields are never more than about 3 milliGauss, except in close proximity to the offending appliance. An example of poor furniture placement is a bed in one room located on the other side of the wall from a large field producer like a refrigerator. Home power users should be aware that all inverters produce big ac magnetic fields (over 100 milliGauss within two feet of the inverter). Locate inverters and other power processing gear (like PWM charge controllers) as far as possible from the family's living space (consider six feet a minimum distance).

By the way, those of you running strictly 12 or 24 VDC household with no inverter may consider that you have no ac magnetic fields, but this is not true. All 12 Volt fluorescent lights and any low voltage DC appliance with a motor do, in fact, produce ac magnetic fields. We measured a field of over 20 milliGauss within 2 feet of

our long tube 12 VDC fluorescent light. Our refrigerator/freezer uses low voltage motors but still has a field of over 10 milliGauss within 1.5 feet of the motors.

Conclusions

After over a year's use, the TriField EMF meter has become a valuable tool for us. I thought I'd only have to sniff the house once and then I'd be done. No such luck, each new appliance, new branch circuit, rearrangement of furniture or appliances, or any other system change also changes the magnetic fields we live within. The TriField meter shows us where we need to make changes in order to minimize our exposure to EMFs.

The TriField is well made, accurate, and, with a price of \$145 (shipping prepaid anywhere in North America), inexpensive. It outperforms instruments costing five times as much and is easier to use.

Access

Author: Richard Perez, c/o Home Power, PO Box 520, Ashland, OR 97520 • 916-475-3179 • Internet e-mail: richard.perez@homepower.org

TriField's Manufacturer: AlphaLab. Inc., 1280 South 300 West, Salt Lake City, UT 84101 • 800-769-3754 • 801-487-9492 • FAX 801-487-3877



WARNING:

DON'T BUY YOUR PV SYSTEM UNTIL YOU READ THIS!

Did you know not all PV dealers are the same?

Not all dealers offer free system design. They haven't all been around for 15 years. Most don't even have a full-time engineer on staff. Many don't carry all the popular brands, only a few. Not all sell other energy efficient products, including lighting, gas room heaters, tankless water heaters, propane refrigerators, and a large selection of books. Most don't have a comprehensive 140 page design guide/catalog. Which makes it all the more amazing that there is ONE DEALER that offers you all this and MORE. We've been in PV for over 15 years, and we have what you need. For our 1995-96 140 page design guide & catalog, send \$5 (credited to 1st order) or call our toll-free number. Credit card orders OK.

Sierra Solar Systems

(formerly Integral Energy Systems)
109H Argall Way Nevada City, CA 95959
Phone: 800-51-SOLAR Fax: 916-265-6151
e-mail: solarjon@oro.net
web site: <http://www.sierrasolar.com>

WANTED:

National & International Distributors
for our growing line of commercial / industrial grade
true PWM charge controllers.
6 to 50 amps continuous, 12 to 48 volts.

- International Licenses possible -

B.Z. Products

7614 Marion Ct., St. Louis, MO 63143, USA
voice: 314-644-2490, fax 314-644-6121
e-mail: frank9966@inlink.com

Do You Need Batteries?...

We're the nations
LARGEST wholesaler
of Trojan Batteries. Our
family-owned business
has OVER 85 years of "Battery
Technology" experience.

**Then
Call**

Residential • Vacation
RV • Marine • Computer
Automotive • Golf Carts
Wheel Chairs • Lawn
Fork Lifts • Mowers • Pallet Jacks
Remote Communications

RAE Storage Battery Company

Since 1943... Quality & Service

If you need Competitive Pricing
& Prompt Delivery, then call:



860-828-6007

Trojan

51 Deming Rd. • POB 8005
Berlin, CT 06037

SERVING VIRGINIA

and Eastern United States

EVs & PVs

- Custom Solar Electric Systems
- Custom Built Electric Vehicles
- 8 Years PV & Electrical Experience
- Certified Electrician
- Catalog Sales
- Service & Installation
- Great Rates & Fair Prices
- Family Run Business
- Send \$5.00 for Catalog/Information

MOONLIGHT SOLAR

2932 Vicker Switch Rd. • Christiansburg VA 24073
Voice (message please)/Fax • 540-381-4971



A Wholesale
Supply House

SOLARTROPE HOT WATER SYSTEMS

Independant Energy ■ Heliotrope ■ Sunearth ■ Harter Ind. ■ Thermal Conversion

SOLAR ELECTRIC SYSTEMS

Siemens ■ Uni-Solar ■ Speciality Concepts

Parts For All Systems

Solartrope Supply Corporation

800-515-1617

THE FUTURE OF LOW COST SOLAR POWER

The Midway Labs' PowerSource Concentrator Module

- Two-stage optical concentration—over
THREE HUNDRED SUNS!
- From 2 Module 230 watt up to
12 Module 1380 watt
- Electrically tracks the sun without any
adjustment, year in and year out.
- TEN year warranty
- Array automatically repositions to the
East after sundown!
- Withstands over 100 mph windloading!
- Made in the USA
- New Wattsun™ Azimuth trackers now
available



6 Modules on a Wattsun™ Azimuth Tracker

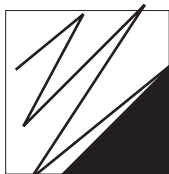

**We've
Moved!**

MIDWAY LABS, INC., 350 N. Ogden, Chicago, IL 60607 USA

Paul Collard or Bob Hoffmann 312-432-1796 (7863), FAX 312-432-1797

Check our home page at <http://www.uic.edu/~slater/midway/>



The New Utility

Don Loweburg and Bob-O Schultze

©1996 Don Loweburg and Bob-O Schultze

Over the last several years the electric utilities have begun using terms like “Distributed Generation”, “Dispersed Applications”, and (one of my favorites) “Virtual Utility”. Those of us who have been in the offgrid RE business for years are somewhat familiar with these terms and in our visionary moments have discussed and dreamed of the “withering away of the grid”. The inquiry of the moment is “What do the utilities mean by these terms”? We suspect they may have a far different vision in mind than we do.

This is what we think: These terms are part of an extensive PR program developed by utility strategists to prepare the general public for acceptance of utility movement into non-traditional market areas. To get the whole picture, we must simultaneously keep in mind the changes happening within utility restructuring. Large economic forces have come together, pressuring for a competitive retail market in power generation. The pattern developing is that the electric utilities, as we know them today, will get out of power generation. The question arises; If they don't make money generating

power, what will they do? Sell services! Power transmission and distribution, conservation, DSM (demand-side management), and information services, are all possibilities. Many large utilities have started joint venture projects with companies like Novell and Cisco Systems (major networking and information service companies). The services include household load management, remote meter reading and even cable TV and information services using the established grid.

It's ironic that as producers of power, utilities had to be coerced (usually with heavy subsidization) to provide incentives for energy conservation. But now, moving into their new role as distributors of energy and services, they are eager to sell conservation and promote distributed generation. Simultaneously, they are attempting to charge off uneconomic generation assets to the rate paying public. By transforming to a Distributed Utility, an IOU (Investor Owned Utility) is achieving two goals at once.

First, it can position itself for profitable access to a new market of services and information (much more profitable than the commodity “electricity”) and secondly, it can unload unprofitable hardware (like nukes and aging coal-fired plants) on the rate payers. This issue will be ongoing and is certainly wrapped up in all restructuring discussions.

IPP's view is, if it's distributed then why is it a utility? A regulated utility is, by definition, a monopoly. Other services like phone, information, entertainment, and security are all non regulated (or nearly so). The regulated wires company should not do business in the services and distributed generation market. These needs can be met by competitive providers. This is no place for a monopoly that controls the feedlines.

Rate Based Incentives

If all goes well in November, voters in Davis, California will vote on implementing the first US rate based incentive (RBI) program. As discussed in previous issues of *Home Power*, RBI programs are locally adopted programs in which communities assess utility bills a 1% surcharge. The surcharge is used to purchase PV power from participating homeowners at a premium rate. The incentive plus the benefits of net metering should allow recovery of 90% of system investment within 10 years. Tom Jensen of Strategies Unlimited has written and researched extensively on RBI. Strategies Unlimited has a web site with more information available at <http://www.strategies-u.com>

On the Right Path

The end user PV market continues to grow. Our companies and many others are experiencing growth.

Home Power magazine is read by more people every month. Alternative Energy websites are experiencing an ever increasing number of hits. The Real Goods Living Center opened in June and is a testimony to the growth of the renewables industry. Our industry is growing under it's own steam; free of subsidies and major government involvement—so far...

Confidence is building that the PV industry can stand on its own. Scott Sklar, director of SEIA and once a proponent of large federal PV subsidies to utilities such as TEAMUP, now editorializes: "...This is SEIA's mandate. The trade association for the solar industry cannot remain fixated on government- they are fickle friends. Now is the time to reach out to the American public and those in our society who know a good thing when they see it. Once we have educated and convinced these sectors, the Congressional policymakers will follow. Except for a paltry few, they are largely followers, not visionaries and leaders." Jim Trotter, president of Cal SEIA, reinforces this sentiment in his recent editorial stating, "...We as an industry need to reexamine the assumptions that lead to the proposition that a subsidy in some form is necessary or even good for the PV market."

We at IPP are very gratified. Followers of this column will note that our strong opposition to the PV industry, and Cal SEIA in particular, "getting in bed" with the utilities and their political cronies is what started IPP in the first place. Welcome aboard, gentlemen!

Another Step in the Right Direction

On May 14, 1996 PG&E filed Advice Letter 1549-E-A. In this document they remove all extra customer charges for net metering customers. In so doing, they join Southern California Edison and San Diego Gas and Electric in compliance with the PV industries sample net metering tariff. With the hard work of CAL SEIA, CEC, and the California PV Collaborative (and many IPP members), we now have all three major California utilities doing it right. Hopefully other utilities will adopt these policies as their model so the entire state can go to net metering as mandated by California law.

Financing

Last issue we reported that Sumitomo bank is making PV loans and that Renewable Energy Development Institute (REDI) is putting together a renewable energy loan database. Another project in the works is being done by the Solar Energy Industries Association (SEIA). They are soliciting a major lender to make a capital commitment for solar loans. The loans would be at normal mortgage rates and be available for solar thermal and photovoltaic projects.

Net Metering in British Columbia

IPP member Robert Mathews of British Columbia has been working to promote net metering in that area. He and other members of the BC Energy Coalition intervened in November 1995 before their Utilities Commission promoting net metering. The British Columbia Utilities Commission Decision section 8.5, dated February 16, 1996 states, "The Commission agrees with the general goal that every energy consumer should eventually have the right to be an energy producer, provided that their production contributes to the economic efficiency (in a full social costing sense) of the energy system. ..." Congratulations! This is a key first step. Keep up the good work. Combined RE industry and citizen action is exactly what is needed to promote and advance the use of renewables.

Net Metering Deluxe in Wisconsin

In what may be the fairest, and is certainly the most progressive net metering policy in the country, Wisconsin Public Service Corporation has a "Wise Buy" program offering both full net metering AND Time of Day(TOD) billing for RE intertied systems. This is a two meter system using separate Buy and Sell TOD meters. Buying power at different rates for peak and off peak times is a common practice in many parts of the country. It reflects more closely the utilities' costs for buying or generating electricity for their customers at different times of the day. It financially encourages the consumer to utilize power off peak which helps the utility manage their generation and load distribution more efficiently.

Selling power to a utility by an IPP on a full net TOD basis is almost like a dream come true. This especially applies to PV only IPPs who generate virtually all their power on peak. Net/TOD billing is ultimately the fairest and most logical way to meter an IPP/Utility intertied system. Rates should mirror costs. Until now however, no utility using TOD billing has been willing to give up the few extra bucks of profit it makes by paying for IPP kilowatts at the traditional non time-differentiated rate. Most offer only the lowest avoided generation cost rate at about \$0.02 kW/Hr. The WPSC TOD rate is \$0.111 peak and \$0.0262 off peak. AND, it applies to all renewables, not just PV.

Wisconsin Public Service Corporation is an investor owned utility (IOU) which makes this "RE Friendly" rate structure even more remarkable. Hats off to ya! IPPs everywhere should be standing on their chairs applauding the WPSC program.

More on Restructuring

The just released Public Citizen's "Restructuring Blueprint" takes stands on many important issues

Independent Power Providers

related to changes occurring in the electricity supply business. Referring to the Blueprint, Matthew Freedman, director of the Critical Mass Energy Project, states: "Today, our coalition releases a blueprint outlining a vision for competition that puts consumers and the environment first. Our plan would make sustainable and affordable energy a priority by ensuring the increased use of renewable energy and efficiency technologies, a guaranteed universal service, and vigorous consumer protection.

The specific mechanisms in our proposal represent and approach that couples market forces with minimum standards. By making all companies adhere to the same requirements for serving the public interest, no single player or industry is disadvantaged and consumers can reap the benefits of competitive markets"

From the Blueprint itself; "On the heavily debated issue of utility stranded cost recovery, the blueprint calls for the burden to fall on utility shareholders in all but the most extreme circumstances. Utilities must take responsibility for making bad business decisions that resulted in uneconomical power plants. The ratepayer bailout now contemplated by state regulators would force consumers to pick up the tab for windfall profits for poorly-run utilities. Early estimates for the recovery of these costs requested by utilities range between \$130 billion and \$550 billion..." Do you remember the S&L bailout? Feel like paying for another one while utility stockholders and managers skate?

IPP is a party to the CPUC (California Public Utilities Commission) Renewables Working Group working on crafting a Renewables Portfolio Standard. The purpose of the standard is to protect the position of renewables in a market that does not yet value externalities, such as clean air and other environmental issues, one of the issues addressed in the blueprint. Shaping up is set of different proposals with stakeholders making supportive or opposing comments. This document will then be presented to the Commission for consideration. IPP is supporting two proposals that simultaneously protect renewables market share and exclude utility Renewable Energy Credits (RECs) for distributed generation. The market should reward innovators; not the fumbling of the nukeball.

Next Issue

A couple of items are on the calendar. Don will attend the commission's next compliance meeting that reviews Southern California Edison's offgrid PV program. We also have another meeting of the California PV Collaborative. More on restructuring. Be the first to tell me the number of times the IPP logo appears in this issue and I give you a free subscription to *Home Power*.

Access

Authors: Don Lowebug, IPP, PO Box 231 North Fork, CA 93643 • 209-877-7080, Internet Email: i2p@aol.com and Bob-O Schultze, PO Box 203, Hornbrook, CA 96044, Internet Email: econnect@snowcrest.net

To join IPP or send tax-deductible donations: IPP, PO Box 231, North Fork, CA 93643 • E-mail: i2p@aol.com • 209-841-7001 or 916-475-3402



COMMUNITIES MAGAZINE

camera ready
b&w

3.5 wide
4.5 high

MicroHydro Specialists

14+ yrs. living with MicroHydro

Makers of "Lil Otto" Hydroelectric Systems

"He's a hard worker who doesn't drink very much!"

Lil Otto is a permanent magnet hydroelectric generator. He works with as little as 1.2 GPM or Heads as low as 20 feet. 12 or 24 VDC output, up to 5 Amps. Comes complete with manual and right nozzle for your site.



\$410. shipped free in Continental USA

CA residents add 7.25% sales tax.

Dealer inquiries invited.

Lil Otto Hydroworks! Bob-O Schultze KG6MM

POB 203, Hornbrook, CA 96044 • 916-475-3401



The Midwest Renewable Energy Association

- Workshop Schedule -

MREA is a grass-roots, non-profit educational organization whose mission is to promote renewable energy & energy efficiency through education and demonstration.

Membership and participation in the MREA are open and welcome to all interested individuals and organizations.

PV / Hybrid Systems	Sept. 7-8
Edible Landscaping & Organic Gardening	Sept. 13-14
A Place to Call Home: A Soulful Look at Alternative Building Techniques	Sept. 20-22
Energize Your Home & Classroom	Sept. 27-29
Batteries & Inverters	Oct. 5-6
Introduction to Renewables & Photovoltaic Systems	October 11-13
Insulated Window Coverings	Oct.12 (1/2 day)
Energy Efficient Construction Techniques	Nov. 9-10
Practical Solar Design for Architects & Engineers	Nov.16



Call or write for more information and course descriptions.

The Midwest Renewable Energy Association • PO Box 249, Amherst, WI 54406
phone (715) 824-5166 • fax (715) 824-5399

SOLAR CHEF®



The Solar Chef will cook or bake any food under the Sun and do it in conventional cooking times. (capable of 500°F)

THE HEALTHIEST WAY TO COOK—FOR YOU & THE PLANET

FOR MORE INFORMATION CALL OR WRITE



503-471-6065
800-378-4189



220 SOUTHRIDGE WAY, GRANTS PASS, OR 97527

Johnson Electric Ltd.

COLORADO LICENSED ELECTRICAL CONTRACTOR #895

Tel: 970-249-0840 Fax: 970-249-1248

Hybrid PV & Wind Remote Electrical Power Systems
Code Approved Installations by Licensed Electricians

Remote Homes • Telecommunications • Water Pumping
Community Water Systems • Lightning / Surge Protection

System Design • Equipment Sales • Trouble Shooting
Turn-Key Installations • Pre Assembled Systems

2210 Industrial Dr., PO Box 673, Montrose, CO 81402



DC/Propane Refrig., Track Rack

AC/DC Inverters, Charge Controller

1-888-SOLARNOW
Toll Free

HORIZON INDUSTRIES

We Sell The Best & Service The Rest



Mention This Ad
& Receive A Free Catalog

2120 L W Mission Rd, Escondido, CA 92029

Mail Order or Fax

(619) 480-8322



Water Pumps, DC Lights, DC Appliances

Batteries, Cables, Switches

Fifth Annual Iowa Renewable Energy Expo & Alternative Fuel Vehicle Showcase



September 7 & 8, 1996
Hawkeye Downs
Cedar Rapids, Iowa

Workshops on wind, solar, PV, energy conservation, agriculture, architecture, vehicles, electrical, utility issues, grass roots issues and projects and displays for children and teachers.



Display Booths • Demos • Speakers • Entertainment • Food

Join our association, participate, come! For more information contact:

Iowa Renewable Energy Assn.

611 Second Street SE, Dyersville, IA 52040

Tom Snyder 319-875-8772 • Stan Eilers 319-365-7314 • Don Laughlin 319-643-5650

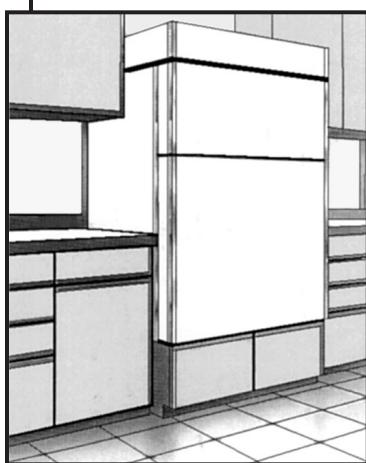

Sun Frost

Energy Efficient

REFRIGERATOR

FREEZER

AC models

for cutting utility bills

DC models

for alternative energy

Write or Call Now for **FREE** Information:
P.O. Box 1101 • Arcata, CA 95521

(707) 822-9095

**CHINESE DIESEL
ELECTRIC POWER**

*WHEN AND WHERE
YOU NEED IT!!!*

In many instances cheaper per watt than your electric monopoly.

The remarkable long life & low price of Chinese Diesel Engines is well known!

Call today for complete information.

**Generator Sets
from \$2250**

Parts in stock for most
Chinese Diesel Engines

CHINA FARM MACHINERY

Tel. (909) 657-0379

Fax (909) 657-8120

World Power Tech

via HP52, page 98
camera ready, b&w
4.7 wide
2.35 high

**SANDERSON'S
REBUILT VACUUMS**

Specializing in 3 & 4 AMP Kirbys
Lower amperage Kirby's are the
ultimate in chore relief -
kind to your batteries and back
alike.

3 AMP - \$175

4 AMP - \$150

For More Information Call
(408) 628-3362

Or Write: 20295 Panoche Rd.,
Paicines, CA 95043



Home Power's Business

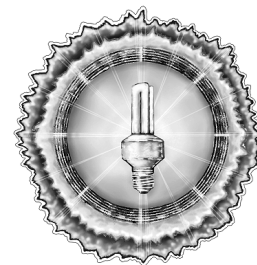

"The man who on his trade relies
Must either bust or advertise."

Sir Thomas Lipton — 1870

Display Advertising

Advertising Rates per Consecutive Insertion

	Single Insertion	Three Insertions	Six Insertions	Ad Area sq. in.
Full Page	\$1,200	\$1,080	\$1,020	64.13
Half Page	\$672	\$605	\$571	32.06
Third Page	\$480	\$432	\$408	21.38
Quarter Page	\$377	\$339	\$320	16.03
Sixth Page	\$267	\$240	\$227	10.69
Eighth Page	\$214	\$193	\$182	8.02
Twelfth Page	\$150	\$135	\$128	5.34

Four process color (CMYK) in any sized advertisement for a flat rate \$185 per insertion. For inserts, and current subscriber/circulation demographics, please call us.

Home Power is published bi-monthly. Ad deadline for the Oct / Nov 1996 issue (*HP* #55) is 19 Aug 1996. Call or FAX 916-475-3179 for further details.

MicroAds

MicroAd rates are 10¢ per character. Characters are letters, numbers, spaces, and punctuation marks. \$15 minimum per MicroAd insertion. Send check with your ad. We do not bill MicroAds.

Home Power Magazine for Resale

Quantities of *Home Power Magazine* are available for resale by distributors, newsstands, bookstores, energy businesses, and others. Please call or write for rates and shipment specifics.

First Class Home Power Subscription

Home Power Magazine (6 issues) via First Class U.S. Domestic Mail for \$36. Many of you have asked for faster delivery of your issues. So here it is: First Class *Home Power*. All First Class issues shipped in an envelope. We start your subscription immediately with the current issue.

International Home Power Subscriptions

Due to the high cost of international mailing, we charge more for *Home Power* international subscriptions.

1 YEAR — 6 ISSUE INTERNATIONAL RATES:

All payments in U.S. currency ONLY!

Canada:	Air — \$36	Surface — \$30
Mexico:	Air — \$38	Surface — \$30
Western Hemisphere:	Air — \$40	Surface — \$30
Europe:	Air — \$53	Surface — \$30
Asia and Africa:	Air — \$64	Surface — \$30
Pacific Rim:	Air — \$64	Surface — \$30

Surface shipment may take up to three months to get to you. All international issues shipped in mailing envelopes. International subs are best paid for by either VISA, MasterCard, or funds from a U.S. bank.

International orders call: 916-475-0830
or FAX 916-475-0941

Back Issues of Home Power Magazine

Back issues through #20 are \$3.25 each (\$4.25 each outside USA) while they last. Sorry no more issues #1-#10, #12, #14, #15, or #36. Back issues of #21 through #45 are \$4.75 each (\$6 each outside USA). Back issues #46 to the present issue are \$5.75 each (\$7.25 outside USA). All back issues are shipped First Class mail in an envelope or box. See this issue's ad index for current *Home Power* back issue specials. The text and line art from back issues #1-#37 on CD ROM (IBM & Mac) at \$29 each.

Second Class Home Power Subscription

Home Power (6 issues) via Second Class U.S. Domestic Mail for \$22.50. Second Class is forwardable for one issue (2 months), so let us know immediately if you move! We start your sub with the next scheduled issue, so please allow ten weeks for your first copy to arrive.

ACCESS ➡ **Home Power, PO Box 520, Ashland, OR 97520 USA**

800-707-6585 or 916-475-0830 Subscriptions and Back Issues

916-475-3179 Advertising and Editorial



SAFETY ALERT

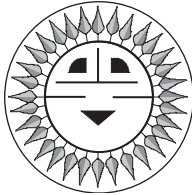

John Wiles

A potential safety problem exists when a stand-alone 120-volt inverter is connected to a house or other structure wired for 120/240-volt alternating current. All PV Dealer/Installers and individuals who have installed such systems should review the following information carefully and take corrective actions where necessary.

Stand-alone PV and PV/Hybrid systems are frequently connected to a building, structure, or house that has been previously completely wired for 120/240-volts ac and has a standard service entrance and load center.

These structures may employ one or more circuits that the National Electrical Code® (NEC®) identifies as a multiwire branch circuit. See Section 100 in the NEC, "Branch Circuit, Multiwire" for a complete definition. These circuits take a three-conductor-plus-ground feeder from the 120/240-volt load center and run it to the loads in the structure where two separate 120-volt branch circuits are split out. Each branch circuit uses one of the 120-volt hot, ungrounded conductors from the 120/240-volt feeder and the common neutral conductor.

In a utility-connected system or a PV system with a 120/240-volt stacked pair of inverters, the 120/240-volt power consists of two 120-volt lines that are 180 degrees out of phase. The currents in the common neutral in the multiwire branch circuit are limited to the difference in currents from any unbalanced load. If the loads on each of the separate branch circuits were equal, then the currents in the common neutral would be zero.

A neutral conductor overload may arise when a single 120-volt inverter is tied to both of the hot input conductors on the 120/240-volt load center. This is a common practice for stand-alone PV homes and I do it in my house. At this point, the two hot 120-volt

conductors are being delivered voltage from the single 120-volt inverter and that voltage is in phase on both conductors. In the multiwire branch circuits, the return currents from each of the separate branch circuits *add* in the common neutral. A sketch of the multiwire branch circuit is presented below. Additional information can be found in the NEC in Sections 100, 210-4, 240-20(b), and 300-13(b), and in the NEC Handbook.

Each branch circuit is protected by a circuit breaker in the ungrounded conductor in the load center. The neutral conductor is usually the same size as the ungrounded conductors and can be overloaded with the in-phase return currents. The circuit breakers will pass current up to the ampacity of the protected conductors, but when both branch circuits are loaded more than 50%, the unprotected, common-neutral conductor is *overloaded and may be carrying up to twice the currents that it was rated for*.

A definite fire and safety hazard exists. All existing stand-alone PV installations using single inverters tied to both ungrounded conductors at the service entrance should be examined for multiwire branch circuits.

The NEC requires that multiwire branch circuits in *some, but not all, cases* have the two circuit breakers tied together with a common handle (or use a two-pole circuit breaker) so that both circuits are dead at the same time under fault conditions and for servicing. This common-handle, side-by-side circuit breaker rated at 15 or 20 amps may be one indication that multiwire branch circuits have been used. Common handle circuit breakers rated at 30 amps and higher are usually dedicated to 240-volt circuits for ranges, hot water heaters, dryers, and the like.

Examination of the wiring in the load center may show a three-wire cable (14 or 12 AWG conductors) with a bare equipment grounding conductor leaving the load center. This may be connected to a multiwire branch circuit. The circuit breakers connected to this cable and the outputs of this cable should be traced to determine the presence or absence of a multiwire branch circuit.

The multiwire circuits must be disconnected or rewired as separate circuits ("home runs") from the load center. Another option is to limit the output of the inverter with a circuit breaker rated at the ampacity of the neutral conductor (usually 15 amps).

With 4000 watt (33-amp) inverters, a 15-amp circuit breaker on the output will certainly limit the output but won't be very popular (only half power output).

A copy of a draft proposal for the 1999 NEC is presented below that addresses this problem.

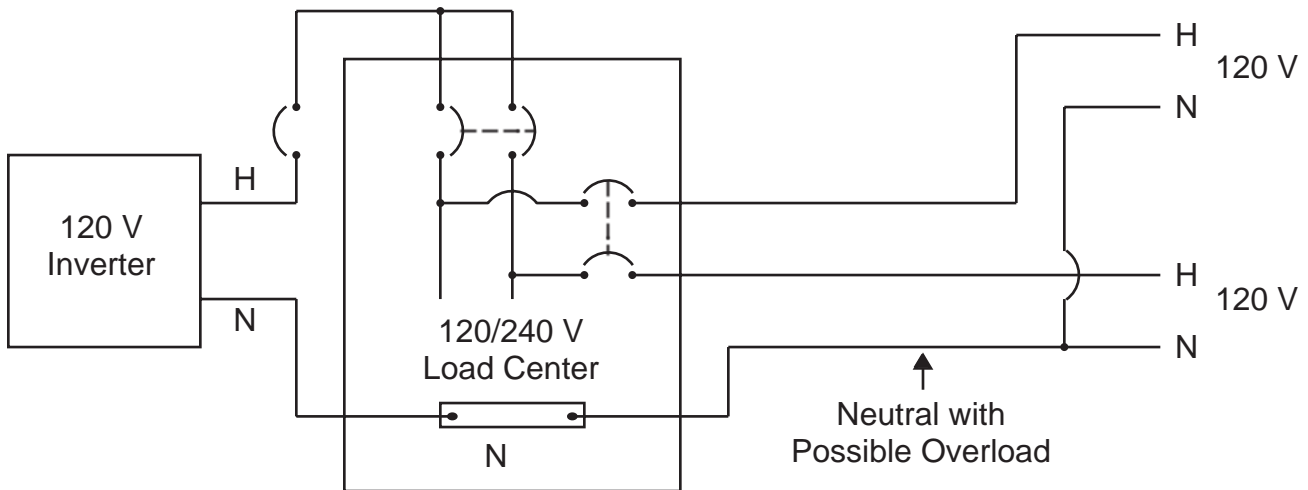

Diagram of a multiwire branch circuit

Draft Proposal for the 1999 National Electrical Code

This draft proposal, if accepted, will provide exceptions to NEC Section 690-14. This section requires that PV systems comply with the provisions of NEC Article 230, Part F, which covers service entrances. Some electrical inspectors are raising the issue that if a house is wired with a 120/240-volt service entrance at 100 amps, then the PV system must supply 120/240 volts at 100 amps — that would require a \$240,000 PV system! Exception 3 to Section 690-14 will permit the PV system to deliver power (current) to the house at less than the rating of the service entrance. Exceptions 4 & 5, shown in the next paragraphs, will allow a 120-volt inverter to feed a 120/240-volt service entrance. The Exceptions are followed by substantiation for the Code Making Panel that must vote on the proposal.

Draft Exception

Exception No. 4: The inverter output of a stand-alone photovoltaic power source shall be permitted to supply 120 volts to a single-phase, three-wire 120/240-volt service entrance or main disconnect when there are no 240-volt outlets and when there are no multiwire branch circuits. In all installations, the rating of the output overcurrent device connected to the photovoltaic inverter shall be less than the rating of the neutral conductor in the load center or service disconnect device in the structure.

Exception No. 5: Where 120-volt multiwire branch circuits are present, the output overcurrent device connected to the photovoltaic inverter shall be rated at no more than the ampacity of the smallest common neutral conductor in the multiwire branch circuits.

Substantiation

Most inverters in stand-alone photovoltaic power

systems have a single 120-volt output. It is common practice to connect this single output to both (in parallel) ungrounded conductors of a single-phase 120/240-volt, three-wire load center and supply current in phase to all 120-volt outlets and appliances. If 240-volt loads were inadvertently connected to the premises wiring, there would be no safety issue since the two ungrounded conductors have voltages that are in phase which would supply the 240-volt connected device with zero volts.

Some residences and other structures are wired with multiwire branch circuits where the two ungrounded conductors of the 120/240-volt single-phase system supply current to separate 120-volt circuits with a common return neutral conductor. If both 120-volt circuits were connected to loads, the return currents in the neutral would be in phase when driven by a 120-volt inverter and this could cause an overloaded neutral conductor while not tripping any overcurrent device. These exceptions recognize this condition and prevent the connection if multiwire branch circuits are present. If they are present, then limiting the maximum current delivered by the inverter through the use of an appropriate overcurrent device will protect the neutral conductors.

It is possible, though unlikely, that a large inverter could be connected to a small load center and overload the neutral in the load center. The last sentence in Exception 4 prevents this from happening.

Summary

There are houses and other buildings that are wired with multiwire branch circuits. The practice is quite common in some areas of the country. Please check your existing installations.

If anyone determines that multiwire branch circuits are common practice in a certain part of the country, please share that information widely and notify me.

Please distribute this article as widely as possible throughout the PV community.

Access

Author: John C. Wiles • Southwest Technology Development Institute • New Mexico State University • Box 30,001/ Department 3 SOLAR • Las Cruces, NM 88003 • Phone 505-646-6105 • FAX 505-646-3841

An NEC Article 690 Task Group, chartered by NFPA, is working on the 1999 NEC with a Technical Review Committee from the Solar Energy Industries Association (SEIA). Those wishing to actively participate should contact Ward Bower at Sandia National Laboratories • 505-844-5206

National Electrical Code ® and NEC ® are registered trademarks of The National Fire Protection Association. The 1996 NEC and the NEC Handbook are available from the NFPA • 1 Batterymarch Park • Quincy, MA 02269-9101 • 800 344-3555 • 617-770-3000



Off The Shelf

The spec sheet directory of renewable electricity

300+ pages, 12 Chapters

"*Off the Shelf* is great for people seriously interested in solar photovoltaic technology who want to know the specifics of the available equipment. This product literature looseleaf is stuffed with information of current state-of-the-shelf photovoltaic system components. We recommend it to all our workshop participants." Johnny Weiss, Director, Renewable Energy Education Program. **Solar Energy International**, Carbondale CO.

"*Off the Shelf* is a must for systems designers, trainers, or those who are thinking of their own system." Paul Maycook, publisher, **PV News**.

"Overall, this is a great effort to pull together a comprehensive of manufacturers and dealers. I look forward to the next edition." Art Boyd, **MARETC, Crowder College**, MO.

"I use it almost every day." Windy Dankoff, **Dankoff Solar Products**.

"This Book is the answer for designers of renewable energy systems...just about every manufacturer in the RE industry...and an appendix listing hundreds of dealers and installers of RE products." Richard Perez, editor, **Home Power Magazine**.

The Cost is \$69.95 including book rate postage.

Outside U.S. inquire

The PV Network News

2303 Cedros Circle, Sante Fe, NM 87505

Voice/fax: 505-473-1067 • e-mail: pvpaulset@aol.com

Our 16th Year of PV-Powered Publishing



Back Issues of Home Power !

Check out HP#53...

It contains an index of all articles back to issue #1.

You can buy back issues individually:

- \$3.25 each for #11, #13, and #16 through #20
- \$4.75 each for #21 through #45 (except for #36)
- \$5.75 each for #46 through #54

Or

Deal #1: All 40 available issues for \$127

Deal #2: 6 or more issues (of #21 through #54) for \$4.00 each (*sent bound printed matter*).

for U.S. ZIP codes only, see page 81 for international back issues.

(Sorry, we're out of issues 1 through 10, #12, #14, #15 and #36). We are planning to compile them into a book. Until then, borrow from a friend. If you have a computer (or a friend with one) download the article you're missing by calling the Home Power bulletin board at 707-822-8640. Or check with your local library; through interlibrary loan, you can get these back issues. Jackson County Library in Oregon has all issues as does the Alfred Mann Library at Cornell Univ.)

Home Power, PO Box 520, Ashland, OR 97520 • 800-707-6585 • 916-475-0830 VISA / MC

**Good Info!
Good Deal!**
in USA
800-707-6585



- DESIGNERS & BUILDERS OF HIGH-PERFORMANCE HOUSING
- DEALERS AND INSTALLERS OF MASONRY STOVES

ALBIE CORE & ENVIROTECH STOVES

GIMME SHELTER

PO BOX 176 • AMHERST, WI 54406
715-677-4289

Solar - Powered Soap?

The natural ingredients of our soaps and bodycare products derive their energy from the Sun, as do our home and business.

Discover the many items for home and personal care in our catalog:

Simmons Handcrafts.
42295 Hwy 36, Bridgeville, CA 95526

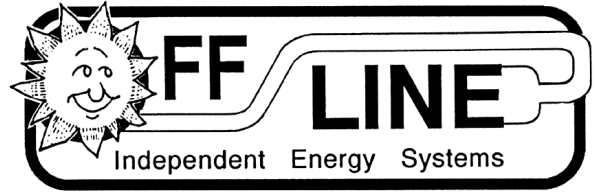

CA Lic. #661052

Our Thirteenth Year Offgrid!

*We will meet or beat any other company's prices.
We provide excellent service and technical support.*

Residential Power • Water Systems • Phones • All Major Brands
Wind • PV • Hydro • Custom Design • Installation • Mail Order

Workshop
October 5

Call for information
(209) 877-7080

e-mail: ofln@aol.com

located in the central Sierra, near Yosemite

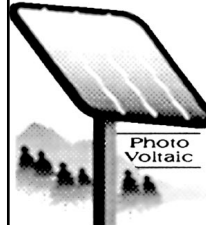

OFFLINE
P.O. Box 231
North Fork, CA
93643



We'll Send You Our
CATALOG
for
\$3



WE WROTE THE BOOK ON ELECTRIC CAR CONVERSIONS

CONVERT IT How-To Manual

by Michael Brown with Shari Prange

Expanded & Updated 3rd Edition
\$30.00 tax & postage included

"We built Mr. Brown's car,
and we won." Bruce Burk,
St. Johnsbury Academy,
1991 American Tour de Sol
Open Class Winner.

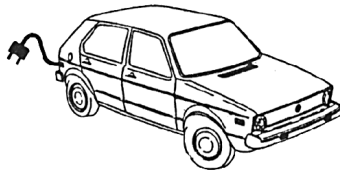

ELECTRO AUTOMOTIVE
POB 1113-HP, FELTON, CA 95018

AIM YOUR PHOTOVOLTAIC PANELS AT THE SUN... ALL DAY, EVERY DAY



American SunCo

FREE

Information package on
Sun Tracker 8

PV Tracking System

- Provides 40% more power
- Accurate even in wind/cold
- Reliable
- Affordable
- Warranteed

American SunCo

PO Box 789H, Blue Hill, ME 04614
(207) 374-5700

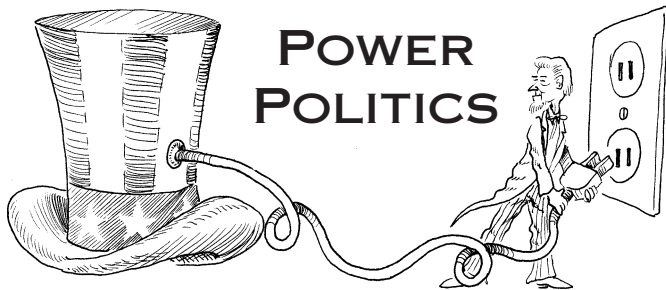

Renew Wisconsin

Michael Welch

©1996 Michael Welch

I sit at Denver Airport having missed my scheduled flight taking me closer to my goal, the Midwest Renewable Energy Fair. Right now I'm mad enough to wish I were an airline/consumer activist rather than an energy activist. The plane due to pick me up in San Francisco was over an hour late because, "They (whoever that is) can't find us a plane to use for this flight." It finally made it, but unfortunately, my next plane out of Denver was right on schedule, pulling away as I ran a quarter mile to the gate carrying my three rather heavy carry-ons.

And now that I am back, my dissatisfaction with United Airlines is boiling over. They messed up on every leg of my travel, except one. The problems included a broken plane, lack of a crew for a scheduled flight, inept customer service representatives, and a surly steward. There was even a pilot who I overheard laugh and say, "Hell if I know!" to a steward who was inquiring on my behalf about takeoff time. This after an hour baking in a plane without air conditioning on the tarmac in Minneapolis.

Oh, well, back to the politics of energy. My intentions were to report on the political goings-on at MREF in this column. Every time I go to MREF, it seems a political hot-bed with lots of rural RE folks taking their utilities to task on a variety of issues. Yet I feel so isolated from it at my Arcata office. From here it is easy to pick up on

the regional happenings in California as well as the national energy politics via the several very fine groups dealing specifically with that, but difficult to find out about other regions.

I wish I had a lot more info coming in from other regions of the country. For instance, I had no idea of the events surrounding the successful fight against the Black Fox nuclear plant in Oklahoma until I got my hands on Aunt Carrie's War Against Black Fox Nuclear Power Plant (see the book review, page 95). This is where you come in. I need your reports from your region. If you can send me substantive information on energy related politics and policy in your neck of the woods, I will do my best to publish it.

Maybe it is best that I live in California, as it has long been thought of as a hot bed of energy policy. Time after time I have heard the statement, "As California energy goes, so goes the rest of the nation." But that is no longer such a good thing. California's politicians and bureaucrats are losing their RE edge as conservative, pro-big business, anti-environment zealots gain more and more power each year.

California is getting close to implementing utility deregulation that will likely benefit the utilities and their largest corporate consumers at the expense of small rate payers. CA still takes the lead as many other states and utilities await the final outcome of our laws. The fight is not over yet, but it would be a pity if other states implement deregulation based on what happens in CA. They could do a lot better.

Even though we seem to be losing our edge out here, California is still so big and powerful that it won't follow the lead of other states that have implemented outstanding programs, such as Wisconsin's net billing law that allows payment for home made electricity at the same rate that consumers are paying the utility for what they use. Instead, CA settles for laws and regulations strongly influenced by the utilities.

Wisconsin Energy Scene

I learned a little from talks and panels at MREF about what is going on in energy politics in the midwest, but not in a form solid enough to write a column. Fortunately, there was a lot of info available from local and regional groups that had set up booths at the fair. Thanks a million to all of them for doing such a great job at educating the public about renewables and grid-based utilities.

The biggest energy issue in Wisconsin at this time is utility deregulation and some related components. Wisconsin has had a strong tradition of positive input from ratepayers and renewable energy proponents in all of its regulatory dealings. Now, much of that is being

tossed aside in favor of fast-tracking retail electricity wheeling and green pricing.

Retail wheeling would allow Wisconsin utilities to sell electricity to any retail customer they please, including ones outside of the state. This is likely to shift costs from large industrial customers to the smaller customers. The current proposal would put wheeling into effect in the year 2000. As it is now, Wisconsin's utility regulations provide its citizens with some of the lowest rates in the nation. But the utilities are attracted to an industrial market in Illinois which has 40% higher rates than Wisconsin's industrial users do. The utilities see enormous profits in such a plan from which the local ratepayers will see no benefit.

Those local ratepayers would have to compete directly with the higher priced market for a limited supply of low cost electricity. Who would win in such a competition? Only the utilities and their largest customers. Wisconsin's air and water will come under increasing stress as the utilities maximize their output from cheap coal-fired plants. Coal-fired emissions are exempt from the state's air-toxic regulations, so the power plants will contend with even fewer environmental constraints than the many dairies in the state.

Additionally, energy and environmentally conscious electric consumers will have fewer energy saving or clean energy options available to them. The largest utilities have ended almost all of their energy efficiency programs in anticipation of deregulation. They are also abandoning their earlier plans to begin developing cleaner energy alternatives like wind, biomass, and solar. This is a disturbing trend being repeated in every state on the verge of utility deregulation.

RENEW Wisconsin points out that the regulatory Public Service Commission's indifference to the clean, job-producing benefits from using more renewable resources is in stark contrast to neighboring Minnesota. There, recent legislation requires the state's largest utility to make substantial investment in wind and farm-grown energy production. Minnesota policy makers find value in diversifying its rural economy by building a home-grown clean energy industry, and many believe Wisconsin should follow that example.

Keep Trying

A coalition of groups has received an Energy Foundation grant to build a team of consumer, environmental, health, and civic groups to push the Green Plan. Called LEED (Local Energy and Economic Development), the coalition will emphasize bringing energy efficiency and locally available renewables into the forefront of the deregulation debate.

Green Pricing

Another program being considered in Wisconsin is Green Pricing. Many polls across the nation show that consumers would pay a higher price for electricity if it comes from renewable resources, and this state is no exception.

The green pricing debate in Wisconsin centers around the reason for implementing such a program. Activists see it as a way that PSC can avoid its responsibility to make the utilities offer renewables as part of the energy mix. And there are many vagaries in predetermining whether such a program would even work. It is possible that green pricing could unleash a vigorous market that the utilities could not ignore when deciding which power sources to pursue. On the other hand, Wisconsin's market could prove too weak to support not much more than a few small scale projects.

RENEW Wisconsin is developing an alternative mechanism called Green Investment which would allow participants to obtain equity interest (part ownership) in their renewable energy investments. This will allow them to reap greater value from their investments as the sources appreciate in value. Hopefully, this would spur even greater interest in a renewable energy market than would the green pricing plans.

Wisconsin Customers Bill of Rights

After an impromptu dinner of renewables activists and business people following a long day at the Midwest Renewable Energy Fair, RENEW Wisconsin Director Michael Vickerman handed me an interesting piece of paper which laid down the rights of utility customers. This draft of a bill of rights is intended for Wisconsinites, but much of it could be adopted to everyone across the nation. It includes:

The right to low bills: The exclusive first right to Wisconsin's inexpensive electricity and no out-of-state retail wheeling.

The right to cleaner energy: 200 Megawatts of new renewable electricity by the year 2000, fewer pollutants including a 30% reduction in damaging mercury emissions from coal-fired plants, and energy decisions that identify and fully value the public health and environmental needs of this and future generations.

The right to fair treatment: Protection from harmful sweetheart arrangements between the subsidiaries of large, multi-state utilities, and living wages for utility workers with strengthened occupational health and safety standards.

The right to equal and universal service: Electrical and energy efficiency services that meet the needs of rural citizens and do not threaten their health or operations,

and electrical service for everyone who needs it to survive, regardless of their age, location, or income.

The right to real choice and real competition: More choices for all consumers as to sources of electricity, and clean energy choices for all consumers.

The right to participate: The ability of consumers and communities to take part in and challenge electrical energy decisions including the siting of generating plants and transmission facilities, and democratic (not bureaucratic) decision making on critical energy decisions that affect everyone.

Kudos

Good luck to all of you wonderful, strong, and kind energy activists in Wisconsin. Thanks for rolling out the welcome mat to the HP crew, you all are the greatest.

Access

Author: Michael Welch, c/o Redwood Alliance, PO Box 293, Arcata, CA 95518. 707-822-7884 voice, 707-822-8640 computer BBS, Internet: michael.welch@homepower.org, http://www.igc.apc.org/redwood

RENEW Wisconsin. Ask for their newsletter and Wisconsin Customer Bill of Rights. 222 South Hamilton St. Madison, WI 53703 - 608-255- 4044

Midwest Renewable Energy Association, PO Box 249 Amherst, WI 54406, 715-824-5166



Illowa Windworks

*Authorized Dealer of Jacobs
& Advanced Aero Technologies*
Servicing the Illinois / Iowa Region
**30% Increased Annual Output
from your Jacobs**

- Advanced Aero Tech. Blades
Designed to fit Jacobs 10 thru 20 KW
- Virtually Maintenance Free
- Resists Ice Build Up

Sales of New & Used Jacobs
Service & Preventative Maintenance Available

**Write or Call Now
For Free Information**

12197 Nelson Rd.
Morrison , IL 61270
(815) 772-4403

Dan & Lori
Whitehead

Adopt a Library!



When Karen and I were living with kerosene lamps, we went to our local public library to find out if there was a better way to light up our nights. We found nothing about small scale renewable energy.

One of the first things we did when we started publishing this magazine seven years ago was to give a subscription to our local public library.

You may want to do the same for your local public library. We'll split the cost of the sub (50/50) with you if you do. You pay \$11.25 and Home Power® will pay the rest. If your public library is outside of the USA, then we'll split the sub to your location so call for rates.

Please check with your public library before sending them a sub. Some rural libraries may not have space, so check with your librarian before adopting your local public library. Sorry, private or corporate libraries are not eligible for this Adopt a Library deal—the library must give free public access. — Richard Perez

To Adopt a Library write or call

Home Power®

PO Box 520, Ashland, OR 97520
1-800-707-6585 or 916-475-0830 or FAX 916-475-0941

Home
&
Heart

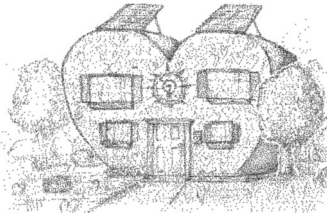

Kathleen Jarschke-Schultze

The cheap land is beyond the power grid. This is one of the factors that has popularized owner built renewable energy homes. The price of lumber continues to rise with no end in sight. The options for alternative building are more popular now than ever before. Now Becky Bee is concentrating on teaching these techniques to women.



Becky Bee

Becky Bee found herself a young mother and in need of a house. She became a builder. She has been building ever since. She became aware that a lot of women were interested in building techniques. There are few places where women can go to learn and implement alternative building techniques. Becky began a personal odyssey that has culminated in Groundworks Natural Earth Home Building.

Groundworks

We received a notice of the First Women's Natural Building Symposium being held the full moon week of June 1-8 1996. (see Happenings, last issue) the directions said near Grants Pass. The symposium was a week long. I couldn't get away for that long so I opted for the Women's Natural Building Fair, held on the last day of the workshop. I'm only 90 minutes from Grants Pass so I asked my good friend Judy Beaver if she'd like to go with me. She would. We did.

I brought up the Groundworks web page but found no directions to the Fair. I phoned and spoke with one of the workshop participants. She gave me directions. As usual I got lost. I stopped for directions and got turned around with new directions, got slightly lost again but recovered on my own. We arrived five minutes before the Fair opened.

Natural Building Fair

The Fair and symposium were held at Becky's house. We got name tags and walked up through the trees towards the house. First we came to the outdoor solar showers set up in a sunny clearing. Women of every age were there at the workshop or arriving for the Fair. A large hand drawn map guided us to the various building sites and other points of interest. Women from the workshop continued to work and were delighted to explain and discuss their work.

Strawbale

A small strawbale studio was one project. When completed it will house future symposium attendees. The south side was mostly windows so only the framing was in so far. The east wall of bales had glass bricks and pottery air vents cobbled into the structure. To soften the lines and add a sculptural feature they used rice straw wattles.

Rice straw wattles are made by filling plastic tube netting with rice straw waste. These wattles are usually used to prevent soil erosion in road building. Some of the women attending brought a pick-up load of wattles. The roundness of the tightly packed wattle cries out for creativity. The wattles were layered around the corner of the room to about waist high. Above that the women had woven branches to make an over hanging skylight. They hadn't figured out the glazing yet but it looked great.

The short walls on the south side, on either side of the door, would place the windows about two feet up. After the framing was put up plywood forms were cut to fit on both sides of the framing with the top open. Some builders sifted dirt to make a slurry in which to 'toss the straw as you would lettuce with salad dressing'. The straw would then be twisted into small bundles and placed in the wall form. The bundles would be pounded down, more straw would be added, pounded and repeated. About every eight inches or so a bamboo rod was placed horizontally across the straw in the form into holes drilled in the framing. More straw added and pounded until the wall was completed. The form can then be removed and moved to the other wall. Indeed, it must be removed so that the wall can dry.

There are two kinds of strawbale buildings, Nebraska style and Post and Beam. The Nebraska style is so

called because the settlers on the great plains built their sod houses so that the weight of the roof rested directly on the sod. So it is with the strawbale home of today. Post and Beam is just that, the whole house is framed out and the bales are placed between the framing. I watched a video called A Straw Bale Home Tour which showcased both types. I concluded that if I were going to build with bales I would have to do more research. Both types have pros and cons.

Cob

Cob building is probably one of the first building techniques used by man. Now it's being recreated by women. You build shapes, walls even whole houses out of Cob. There is an art gallery in Murphy, Oregon made by a crew of Becky's. The Cobnet web site has pictures of this gallery.

You can make Cob by mixing your soil with sand and moistening it. After shaping a bit you take a short stick and push bits of straw into the mound. Continue building up the mound and pushing the straw in every so often. The straw acts like thread sewing material together and gives it strength.

The women had taken over a patio under the trees and were building some cob sculpture. A life size woman rising from a tree trunk, a Rubenesque earth mother were part of the motif that would become a gazebo.

The Rest

Becky had opened up her home to the workshop and the Fair. Instructive videos played in the living room all day. One bedroom had been set up as a resource room. There were many books, some handouts (like the Cob Builder's checklist), access information and order forms for other builder's workshops or their reference materials.

As it was the last day of the Symposium women were taking their leave as the Fair progressed. Everyone I saw and spoke to was excited about what they had learned and eager to put it into practice.

Future

A Groundworks workshop for women and men on the hybrid cob building will be held near Eugene, Oregon on Aug. 17th to 22nd. For more information call 541-933-2166.

A Groundworks workshop for women only on the hybrid cob building will be held near Grants Pass, Oregon on Sept. 1st to 7th. For more information call 541-471-3470.

Dishwasher Soap

While at the Midwest Renewable Energy Fair I heard that electric dishwasher soap is bad for septic tanks.

The solution is to flush about 1/4 cup of dry yeast down the toilet or drain once a month. Also cabbage is good for a septic system. One woman I know said she and her husband tossed a head of cabbage into their septic tank when they built it.

Access

Kathleen Jarschke-Schultze is dreaming of Cob yard art at her home in northern-most California, c/o Home Power Magazine, PO Box 520, Ashland, OR 97520 • 916-475-0830 Internet Email: kathleen.jarschke-schultze@homepower.org or kjs@snowcrest.net

Groundworks Natural Earth Home Building, PO Box 381, Murphy, OR 97533 Website: <http://www.teleport.com/~sparking/cob/door.html>



SUNROOM CONSULTING

Services to help the do-it-yourselfer.

Integrate a sunroom into your home using the best cost effective passive methods & heating to cost ratios.

May include sketches, sources for non-off-the-shelf components & tricks to get extra efficiencies without large expensive items.

Send or call for an informative packet & questionnaire on your home.

Harold Sexson
5445 E. Caron St.
Paradise Valley, AZ 85253

phone (602) 998-9055
fax (602) 998-9067

HAPPENINGS

AFRICA

Needed: PV Volunteers for Africa. Solar Energy International (SEI) is organizing volunteers trained in the design and installation of small stand-alone photovoltaic systems. This pilot program, a component of SEI's INVEST Program, provides selected volunteers with an opportunity to work with small African businesses and community groups. Participants will work under the direct supervision of Energy Alternatives Africa (EAA). The EAA is a leading African organization promoting PV rural electrification.

To support this charitable program, volunteers must make a one year commitment and be responsible for paying 50% of their travel and in-country expenses. The total amount a volunteer needs to provide for the entire in-country year is approximately \$5,000. The other 50% will need to be raised by SEI and EAA.

Potential volunteers are required to successfully complete SEI's PV Training program (or equivalent) as a prerequisite. The full four weeks of intensive technical training will cost each participant an additional \$1700 for workshop tuition. Volunteers can complete the required training August 5-August 30, 1996.

To find out more about EAA please see Home Power Magazine issue #41. For background information about SEI please see Home Power Magazine issues #21, 31, 32, 49 & 50.

Solar Energy International, PO Box 715, Carbondale, CO 81623, 970-963-8855, Fax 970-963-8866 • e-mail: sei@solarenergy.org; Web: <http://solstice.crest.org/renewables/sei/>

AUSTRALIA

Race with the Sun across the Australian Outback 1996 World Solar Challenge. Come join Team New England in the Australian Outback for three weeks of solar car racing beginning mid-October as they enter the 4th World Solar Challenge, the toughest race of its kind in the world. For \$10,000, Team New England will provide you with round trip air fare to Australia, all meals and lodging across the outback during your entire stay and a once in a lifetime chance to vie for the World Championship. Your name will appear on Team New England's solar car entry along with their corporate sponsors. You will take part in all events surrounding the race along the 3010 km route as a guest member of Team New England. Sunglasses are mandatory. For more information please contact: Team New England, Alan Rux—UML Electrical Engineering, One University Ave, Lowell, MA 01854, 508-934-3330 (message phone), 508-934-3061 (team fax), e-mail: GarrisonS@Woods.UML.Edu. Your \$10,000 contribution is tax-deductible.

CANADA

The "Alberta Sustainable House" is now open for public viewing every Saturday 1:00-4:00 PM free of charge. The first of its kind in Canada, the project emphasizes cold-climate state-of-the-art features/products based on the founding principles of occupant health, environmental foresight, resource conservation, AE, recycling, low embodied energy, self-sufficiency, and appropriate technology. Already in place: R17 windows, environmental foresight, resource conservation, AE, recycling, low embodied energy, self-sufficiency, and appropriate technology. Already in place: R17 windows, multi-purpose masonry heater, solar hot water, greywater heat exchangers, LED and electroluminescent lighting, solar cookers, and others. Under development: hydrogen fuel cells, Stirling co-generator, Tesla bladeless steam turbine, and others. Contact: Jorg Ostrowski, Autonomous & Sustainable Housing Inc/Alternative & Conservation Energies Inc, 9211 Scurfield Dr NW, Calgary Alberta T3L 1V9, Canada; 403-239-1882, Fax: 403-547-2671

The Institute for Bioregional Studies was founded to demonstrate and teach recent ecologically-oriented, scientific, social and technological achievements that move us toward ecological, healthy, interdependent and self-reliant communities. For more info: IBS, 449 University Ave, Charlottetown, Prince Edward Island C1A 8K3, Canada; 902-892-9578.

MONACO

The 2nd Monte Carlo Rendezvous of Electric Vehicles, Oct. 17-20, 1996. International EV rallye and exposition. For more info: Editions & Promotions Internationales, 11 Boulevard Albert-I, MC9800 Monaco • phone: 92 16 03 76.

PHILIPPINES

The 3rd International Renewable Energy Asia Pacific '96 (REAP'96) Exhibition and Conference will be taking place in Manila, Philippines, October 1996. This three day event for both the conference and exhibition and is dedicated to Solar Photovoltaics & thermal, wind, biogas/biomass and hydro projects in the Asia Pacific region. The conference will focus on marketing strategies, project financing, policies and incentives for the implementation of renewable energy projects in the Asian countries. Exhibitors will display their latest in renewable energy and energy efficiency products and services. For more information contact Michelle Hassall, Project Manager, 5/F 3 Wood Road, Wan Chai, Hong Kong. Tel: +852-2574-9133 Fax +852-2574-1997.

NATIONAL

American Solar Energy Society National Tour of Solar Homes. October 19. Various locations throughout the U.S. For info: ASES 303-443-3130 • ases@ases.org • <http://www.ases.org/solar>.

Online Energy Info Resources—If you are

looking for information on energy efficiency or renewable energy technologies, the US Department of Energy (DOE) has two sources of online access. The Energy Efficiency and Renewable Energy Clearinghouse (EREC) BBS Online Service offers users free access to text files, share and freeware programs and utilities, and a free publication ordering system. The service is accessible via the Internet's World Wide Web at <http://erecbbs.nciinc.com> or by modem at (800) 273-2955. The Energy Efficiency and Renewable Energy Network (EREN) is also accessible on the World Wide Web at <http://www.eren.doe.gov> and provides links to hundreds of government and private internet sites. EREN also offers an "Ask an Energy Expert" online form that allows users to e-mail their questions directly to specialists at EREC. For more information please call (800) 363-3732.

American Hydrogen Association, national headquarters, 216 South Clark Dr, Ste 103, Tempe, AZ 85281, 602-921-0433, fax 602-967-6601, e-mail: aha@getnet.com "Prosperity Without Pollution" web site: <http://www.getnet.com/charity/aha>

Energy Efficiency and Renewable Energy Clearinghouse (EREC) is offering free booklets on Solar Water Heating (FS119) and Residential Solar Heating Collectors (FS112) contact EREC: Phone: 800-DOE-EREC (363-3732); mail: EREC, PO Box 3048, Merrifield, VA 22116; e-mail: energyinfo@delphi.com; TDD: 800-273-2957; The information can also be downloaded via the DOE's BBS at 800-273-2955 or via internet: <http://www.eren.doe.gov>

Visit AWEA's (American Wind Energy Association) home page on the World Wide Web. (<http://www.igc.apc.org/awea>) Visitors to AWEA's home page can obtain information about the US wind energy industry, AWEA membership, small turbine use, and much more.

Tesla Engine Builders Association (TEBA) provides information about a practical and efficient steam turbine available to the home power producer. The "Tesla Turbine" is the only high power turbine that can be constructed using only simple machining techniques and can operate satisfactorily using only 100 lbs of steam pressure. For more information send an SASE to: TEBA, 5464 N Port Washington Rd Ste 293, Milwaukee WI 53217-4925; or visit our WWW site: <http://www.execpc.com/~teba> e-mail teba@execpc.com

ARIZONA

The State of Arizona is now offering a tax credit for installation of all types of solar energy systems. A solar technician certified by the Arizona Department of Commerce must be on each job site. For info contact ARI SEIA; 602-258-3422.

Photovoltaic Design and Installation! Solar Energy International (SEI) announces a hands-on, how-to workshop in Tucson, AZ.

The Workshop will take place November 4th through Nov. 9th, 1996 at the Cooper Environmental Science Campus (CESC). CESC is a non-profit education campus dedicated to enriching children's lives through environmental education. Over 6,000 students a year attend classes at the campus. Over the last three years SEI has participated in yearly workshops with the aim of taking the campus "off-the-grid". By the end of this workshop CESC will be completely solar powered. Lodging is available on the site and included in the workshop tuition of \$450.00. For more information contact: Solar Energy International, PO Box 715, Carbondale, CO 81623, 970-963-8855, fax 970-963-8866. E-mail sei@solarenergy.org

ARKANSAS

Sun Life is now conducting "Third Saturday Seminars" on inexpensive building techniques. Their focus is to teach home building from materials that can last a thousand years and cost less than conventional wood-framing. These are hands-on, all-day workshops. Contact Loren at PO Box 453, Hot Springs, AR 71902.

CALIFORNIA

1996 North American EV & Infrastructure Conference will be held December 11-13, 1996 in San Diego, CA. The Conference will provide up-to-date commercial and technical information to audiences of all levels. Marketing, government and business issues will be addressed, as well as technical advances made in battery, vehicle and infrastructure development. For more information contact EVAA, 601 California St Ste 502, San Francisco, CA 94108, 415-249-2690, fax 415-249-2699, e-mail: ev@evaa.org

Offline Independent Energy Systems Workshop: Residential Photovoltaics For Beginners - Saturday, October 5, 1996. The class will begin with a tour and discussion of our own PV system, which includes water pumping and telecommunications. We will then develop the following topics: basic systems types, determining power needs, the PV array, the battery, and inverters. We will discuss how it's all put together such as any special wiring needs, code requirements and safety, instrumentation and controls. We will also look at how to LIVE with PV in relation to appliances, computers, and entertainment equipment, attitude and awareness. The workshop will be held at the Offline home/office about an hour from Fresno, California in the Central Sierra. Cost is \$35 per person or \$45 for two together. For further information, reservations and directions, please call, write, or e-mail Don and Cynthia Loweburg, Offline Independent Energy Systems, PO Box 231, North Fork, CA 93643, 209-877-7080. internet ofln@aol.com

The Solar Living Institute 1996 Workshop Schedule: Aug 10—Realizing the Dream—planning & buying the perfect country home

property & developing your homestead, Aug 11—Planning & building your renewable energy home, Sept 14—Straw bale construction, Sept 15—Planning & building your renewable energy home. Each day-long workshop costs \$100 and includes a catered vegetarian box lunch. To register or for more info contact: Real Goods Institute for Solar Living, 555 Leslie St, Ukiah, CA 95482-5507, 800-762-7325.

First Ever National Railbike Festival, Sunday October 13, 1996, 10 am to 4 pm Jamestown, California (near Yosemite). Bring your won railbikes and ride in the foothills of California's gold country on the Sierra railroad which runs through Sonora, Jamestown and Chinese Camp. (Riders will have to sign a waiver and ride at their own risk.) Swap railbike stories and compare experience. Railbikes for novices will be available. Don't miss this historic event! For information call Railbike International, 415-453-8886.

COLORADO

Solar Energy International (SEI) is offering "hands-on" workshops on the practical use of solar, wind, and water power. The 1996 Renewable Energy Education Program (REEP) features one and two week sessions: PV Design & Installation—August 5-16; Advanced PV—August 19-30. Experienced instructors and industry representatives teach how to build homes and RE systems. Learn in classroom, laboratory and through field work. The workshop series is for owner-builders, industry technicians, business owners, career seekers and international development workers. The small, intensive and fun workshops may be taken individually or as a comprehensive program. The cost is \$550 per week. SEI is a non-profit educational organization dedicated to furthering the practical use of RE technology. Contact: SEI, PO Box 715, Carbondale, CO 81623 or call 970-963-8855, Fax 970-963-8866, e-mail—sei@solarenergy.org

Visit the new National Wind Technology Center operated by the National Renewable Energy Laboratory, just outside of Golden, CO. The facilities assist wind turbine designers and manufacturers with development and fine-tuning and include computer modeling and test pads. Call in advance, 303-384-6900, Fax 303-384-6901.

The 7th Annual Crestone Energy Fair will feature Sun Day in Crestone Town Park, September 1 and solar site tours on Labor Day September 2, 1996. Event followed this year by Natural Building Workshops, Sept. 3-5. Write Box 222, Crestone, CO 81131.

FLORIDA

Alternative energy car racers—here's your chance to shine. The Florida Solar Energy Center is calling all cars for the fifth annual SunDay Challenge, a 70 mile rally along public roadways from Cocoa to Orlando, FL. This non-gas guzzling alternative to Florida's Daytona 500 is set for September 21, 1996 and designed to promote the use of vehicles

powered by alternative energy to meet the energy and environmental needs of the future. Alternative racers wishing to participate in the SunDay Challenge road rally must complete an entry form from FSEC and return it by September 6, 1996. Vehicles built by students, private individuals and entrepreneurs can participate in one of four classes (limit of 10 vehicles per class), Commuter solar and electric vehicles; Tour de Sol racing vehicles; cross-continental vehicles; and other alternative-powered vehicles. For more information contact Bill Young at 407-638-1458 or Fax 638-1010.

IOWA

Fifth annual Iowa Renewable Energy Expo & Alternate Fuel Vehicle Showcase, September 7 and 8, Hawkeye Downs, Cedar Rapids, IA. Workshops, Display Booths, Demos, Speakers, Entertainment, Food. Join our organization. For info: Iowa Renewable Energy Association, PO Box 2132, Iowa City, IA 52244 • 310-338-3200. (see their ad this issue)

MICHIGAN

Sky View Farm, a solar and wind powered homestead, is offering six half-day workshops this summer (August 10 & 24). Each workshop will include an introduction to passive solar housing, solar and wind energy systems, domestic water heating and pumping, Permaculture, and rain water catchment. Participants will receive take home literature and sample system schematics. For more information contact David VanDyke, 314 West Valley Road, Maple City, MI 49664. Phone (616) 228-6433.

MISSOURI

The Missouri Renewable Energy Association is a non-profit educational organization, promoting energy sensible technologies as a solution to global environmental pollution. Improved energy efficiency, water conservation, recycling, and composting are just a few of the topics on our agenda. We encourage local government, businesses, schools, and individuals to become involved by joining the MO.REA today. For information contact Ray Wathswski, PO Box 104582, Jefferson City, MO 65110, 573-634-5051

MONTANA

Sage Mountain Center, a Retreat and Educational facility, is offering Life Skills Workshops during the summer. Dedicated to promoting deeper awareness of one's self and one's environment, this years theme is "Create Your Living Space". Workshops include: 8/17 Cordwood Construction. A harmonious blend of function, form, and economy is at the heart of these hands-on, one day workshops. \$45 per person includes class, lunch, and literature. For pre-registration and details write Christopher Borton or Linda Welsh at Sage Mountain Center, 79 Sage Mountain Trail, Whitehall, MT 59759 or call 406-491-0954.

NEW YORK

Solar Energy International (SEI) is offering a

special workshop for Northeasterners who want to get their hands-on!

PV Design & Installation will be a one week workshop Monday October 14 through Saturday October 19. Instruction will be conducted at an off-grid location near Woodstock, NY. The workshop tuition cost for all six days is \$550.

Workshop topics include: Solar site analysis, system sizing, PV modules, controllers, batteries, inverters and appliances, demonstrations, lab exercises and hands-on installation. No prior experience or training is required—everyone is welcome!

For more information contact: SEI, PO Box 715, Carbondale, CO 81623 or call 970-963-8855, Fax 970-963-8866, e-mail—sei@solarenergy.org • For local housing & logistical information please contact SEIs local co-sponsor: Larry Brown at Sun Mountain, PO Box 1364, Olivebridge, NY 12461, 914-657-8096.

The New York State Electric Auto Association (NYSEAA) is dedicated to sharing current electric vehicle technology. Monthly meetings, for date and location call Joan at 716-889-9516

NESEA Sustainable Transportation EV96, September 16–18, 1996, Madison Square Garden, New York City. The symposium will attract decision makers from the auto industry, transit bus industry, business, electric utilities, fleet management, policy makers agencies, electric vehicle component manufacturers, engineering and consulting firms, transportation planners, non-profits and universities who will share and network. An extensive trade show will showcase road-ready electric and hybrid sedans, pick-ups, vans and buses, as well as cutting edge concept vehicles and related components and services. Sessions will include: Advanced EV Technology, Hybrid EV Technology, Integrating EVs into Your Fleet, Fundamentals of Building an EV, Business & the EV Industry, Planning Sustainable Transportation, and Buses of the Future. For more information contact; NESEA, 50 Milles St, Greenfield, MA 01301, 413-774-6051, fax 413-774-6053.

NORTH CAROLINA

Wind Power! Solar Energy International (SEI) will conduct a one week, hands-on course on wind power. This course will be held Oct. 21–26th, 1996. Mon-Sat 9 am-5 pm. Call SEI, PO Box 715, Carbondale, CO 81623, 970-963-8855, fax 970-963-8866. E-mail sei@solarenergy.org

OHIO

The Great Lakes Electric Auto Association's mission is to contribute to the freeing of the US automobile market from dependency on petroleum through advancements in electric and hybrid/electric technology. For more information: Larry Dussault, GLEAA, 568 Braxton PI E, Westerville, OH 43081-3019, 800-GLEAA-44, 614-899-6263, Fax 614-899-1717. Internet: DUSSAULT@delphi.com

Solar and wind classes taught at rural solar and wind powered home with utility back-up. Maximum of 12 students. Must advance register. \$40 fee per person, \$45 per couple and lunch is provided. Please advise of dietary restrictions. Class #1 will be full of technical info, system design, system sizing, and NEC compliance, etc. Students will see equipment in use. Students may also choose class #2 and set-up a system (hands-on training), equipment selection, installation of modules, mounts, controller, inverter, and battery bank.

Dates: Aug. 10, Sept. 7, Oct. 5, Nov. 2, Dec. 7. All classes held from 10:00 am-2:00 pm on Saturday. Call 419-368-4252 or write Solar Creations, 2189 SR 511 S, Perrysville, OH 44864-9537.

OREGON

APROVECHO RESEARCH CENTER offers 3 month training sessions in appropriate technology, sustainable forestry and organic gardening. Classes begin September, January (1 month in Mexico), & March. Daily classes 8:30-5:30. Cost is \$500.00 per month, includes room, board. For more info: 80574 Hazelton Rd., Cottage Grove, OR 97424. (503)942-8198

SOUTH CAROLINA

Green Village '96: The Southeastern Sustainable Communities Exposition, September 13–14, 1996 in Charleston, SC. For more information contact Jean-Paul Gouffray, South Carolina Energy Office, PO Box 21655, Charleston, SC 29413, 803-577-2103

TENNESSEE

Bioenergy '96, The Seventh National Bioenergy Conference, September 15–19, 1996 in Nashville, TN. (Geared toward industry and cities). For more info contact the host, Southeastern Regional Biomass Energy Program, Tennessee Valley Authority, CEB 3A, PO Box 1010, Muscle Shoals, AL 35662-1010

VERMONT

Free PV Workshops for beginners to experts given by David Palumbo of Independent Power & Light, First Saturday of every month at the Palumbo/IP&L PV and microhydro powered off-grid neighborhood. Participant interest will determine which of the following topics will be discussed and demonstrated (as practical): site selection, PV modules, batteries, charge controllers, inverters, lighting (ac & DC), balance of system components, system monitoring and maintenance, water (finding it, developing it, transporting it, pumping it, and getting power from it), snow (living with it, playing with it, and removing it), ponds, living in cold climates, living with our woods, heating with wood, and root cellars. Visit a beautiful part of Vermont and meet people who are either living with renewable power or considering it. David Palumbo has taught workshops in the past with the fine people of Solar Energy International and with the real good folks of the Solar Living Institute.

Call, fax, or write for your reserved spot, information, and directions. 9 am to 3 pm the first Saturday of every month. David Palumbo/ Independent Power & Light, RR1 Box 3054, Hyde Park, VT 05655, call or fax 802-888-7194. This is a freebie so bring your own lunch and coffee. We will supply our own pure drinking water, and a great pond for swimming if you are so inclined.

WASHINGTON

GreenFire Institute is offering weekend workshops on straw bale construction basics. Learn all about the theory and practice of straw bale construction, while actually putting up the walls and top-plate of a small, code-approved structure. Sessions alternate hands-on building experience with lectures and presentations. August 10–11, Roslyn, WA (post & beam cabin; \$175); September 21–22, Whidbey Island, WA (post & beam studio \$175). Other workshops involving straw bale construction are also offered. For more information contact: GreenFire Institute, 1509 Queen Anne Ave, N #606, Seattle, WA 98109. 206-284-7470. E-mail: GreenFyr@aol.com

WASHINGTON, DC

SOLAR 97 American Solar Energy Society Conference. In conjunction with Soltech 97 & AIA Committee on the Environment Symposium. Submittal of papers due by Oct. 1, 1996. For info: ASES 2400 Central Ave Suite G1, Boulder, CO 80301 • 303-443-3130 • ases@ases.org • http://www.ases.org/solar.

WISCONSIN

The Midwest Renewable Energy Association Fall Workshop Schedule. Sept. 21–22: A Place to Call Home: A Soulful Look at Alternative Building Techniques. Sept. 27–29: Energize Your Home or Classroom, Instructors: MREA Staff and others, Location: Central Wisconsin Environmental Station, Amherst Junction, WI. Cost: Please call MREA office. Learn more about energy conservation and renewable energy through experiments and demonstrations. Energy education activities, classroom projects, and curriculum ideas for grades K-12 and youth groups will be explored. Tour alternative energy homes in the area. Co-sponsored by the Central WI Environmental Station, Midwest Renewable Energy Association and WI Center for Environmental Education. 1 UWSP credit available. MREA is a grass-roots, non-profit educational organization whose mission is to promote renewable energy and energy efficiency through education and demonstration. Membership and participation in the MREA are open and welcome to all interested individuals and organizations. Significant others may attend with you for 1/2 price. For more information call or write MREA, PO Box 249, Amherst, WI 54406; phone 715-824-5166, fax 715-824-5399





**Good
Books**

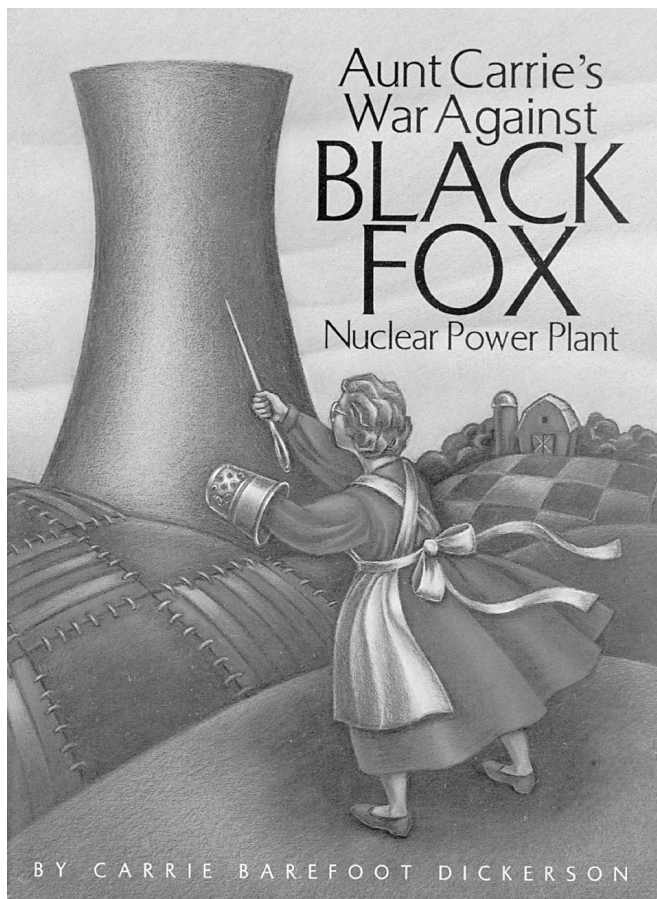

Written by Carrie Barefoot Dickerson

Reviewed by Michael Welch

The cover of this book says a lot about its content. A grandmother takes up needle and thread to fight a scary and unsafe monolith looming over her patchwork countryside.

This book is the story of Carrie Dickerson's successful fight against a nuclear power plant on the verge of construction near her community of Claremore, Oklahoma. She makes great personal and financial sacrifice in her efforts. She raises money by making and auctioning quilts, and sells her own farmlands and business in order to finance her organization's strategies of delay.

The book makes it obvious that without her dedicated help, The Black Fox nuke plant would have been built.

It is well written with the help of Carrie's daughter, Patricia Lemon. It is also well researched through the family's access to thousands of documents, courtroom briefs, and a solid paper trail left by the principles in the case. After reading the book, I could find few inaccuracies or omissions, and those that I did find were minor.

To say the least, this book is an inspiration. While most of us are not willing to make the kind of sacrifices that Carrie outlines in her book, she stands as a shining example of what one person can do if they set their mind to it. And as an energy activist myself, I find good reasons to continue the work I do. The support structure for activists is usually pretty weak, but Carrie found a lot in her family, friends, and even by treating her opponents with respect, dignity, and active friendliness.

Carrie's book will give you a good education about nuclear power and its dangers as you follow her own educational process. It also provides insight into the "good old boy" and government networks that support the taking of rural lands for potentially dangerous and polluting use.

I have only one serious bone to pick with the book. Too many times Carrie bemoaned the involvement of those using civil disobedience to slow the spread of nuclear power. It was almost like a vendetta for her to attack those actions. She perceived that the use of non-violent protest hurt her cause and that she achieved her victory in spite of protest. I believe that to be a narrow, short term view. While it may have hindered her local efforts, the use of non-violent civil disobedience propelled the anti-nuclear cause into the national limelight, helping insure that another nuclear power plant will not be built in the U.S.

All in all, this is a great book, and I highly recommend it for anyone interested in nuclear power and anyone that enjoys heart warming inspiration.

Access

Reviewer: Michael Welch, c/o Redwood Alliance, PO Box 293, Arcata, CA 95518 • 707-822-7884 • Internet Email: michael.welch@homepower.org • World Wide Web: <http://www.igc.apc.org/redwood>

Aunt Carrie's War Against Black Fox Nuclear Power Plant, by Carrie Barefoot Dickerson, • ISBN 1-5718-009-2 • Council Oak Publishing Co., Tulsa, OK 74120



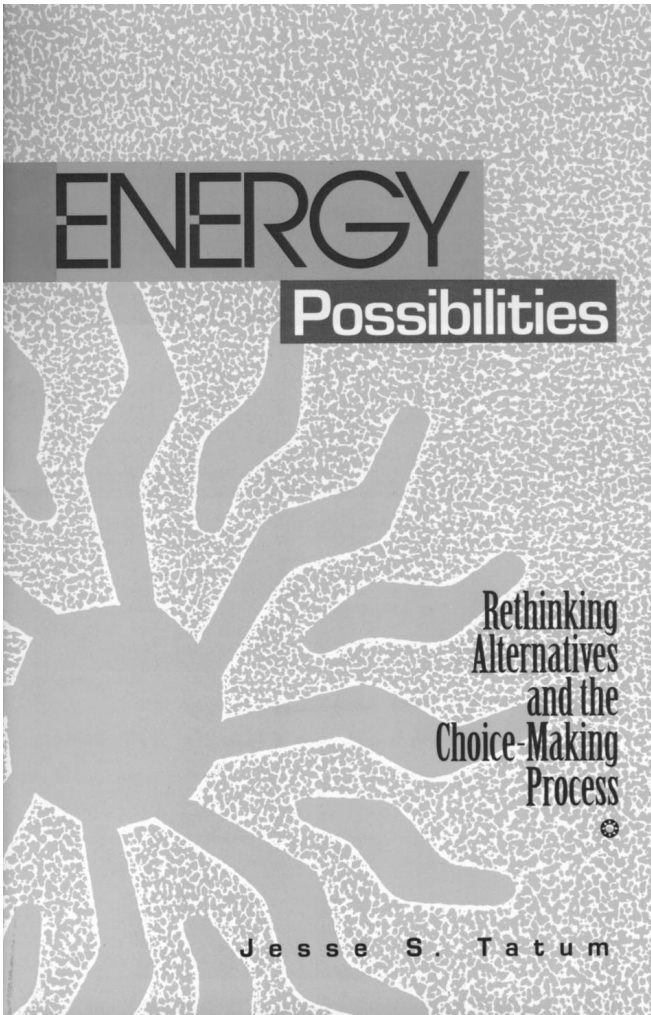

of existing energy structures. In the chapter “Exploring the Option Space” the home power movement is reviewed as an example of what is possible and as an illustration of the connection between energy and values.

This book is radical—it digs down to root issues. Jesse Tatum asks the reader for the responsibility and commitment to rethinking the alternatives. Buy this book, read it...then send it to a legislator or policy-maker. The core questions and concerns contained in this book need to be considered in the institutions of our democracy...as well as in our homes.

Access

Energy Possibilities (ISBN 0-7914-2596-7) is available through: State University of New York Press, State University Plaza, Albany, NY 12246-0001 • 518-472-5000. Cost in paperback is \$9.95 plus shipping.



Written by Jesse Tatum

Reviewed by Bill McKee

Energy Possibilities is a challenge. It challenges and rewards on many levels and for this reader it generated a cascade of further reading—surely the mark of a good book. Its fundamental challenge is posed with the simple little question, “How do we wish to live in this world?” Jesse Tatum’s intent is, “...to drop the matter of energy more squarely in the reader’s lap where ultimately and inevitably is must lie, burden that it may be.” That this burden, this matter of energy has conventionally been approached with a “radically impoverished imagination” is a central concern of this book.

Energy issues are viewed through the broad perspective of Science, Technology, and Society studies. From economics to the environment the traditional concerns are touched upon, but the strength of this book lies in its examination of the social impact



the Wizard speaks...

Who's Driving

There are three potential driving forces behind technology. These are the physical, the social, and the spiritual. Throughout history, technology has been driven by some combination of these forces.

For most of human history the driving force was physical. The need for food, clothing, shelter, and warmth formed the major impetus behind primitive technology.

As civilization advanced, the social aspect began its contribution to the forces driving technology. Economics, politics, and religion took their places as forces which drive technology.

Today, the social, even more than the physical, is the major driving force behind technology. We are at a crossroad where spiritual forces must strongly enter the equation. To date, only in the artistic and environmental areas does the spiritual aspect tend to have a place as one of the forces driving technology.

Spiritual driving forces can satisfy both physical and social needs without the major impacts on the environment and social fabric which we see today. The alternative is that technology will begin to drive itself and create a very sterile and unfriendly environment. Take control. Drive.



Needed: PV Volunteers for Africa.

Solar Energy International (SEI) is organizing volunteers trained in the design and installation of small stand-alone photovoltaic systems. This pilot program, a component of SEI's INVEST Program, provides selected volunteers with an opportunity to work with small African businesses and community groups. Participants will work under the direct supervision of Energy Alternatives Africa (EAA). The EAA is a leading African organization promoting PV rural electrification.

To support this charitable program, volunteers must make a one year commitment and be responsible for paying their travel and in-country expenses. The total amount a volunteer needs to provide for the entire in-country year is approximately \$5,000. Additional funds will need to be raised by SEI and EAA to cover administrative costs.

Potential volunteers are required to successfully complete SEI's PV Training program (or equivalent) as a prerequisite. The full four weeks of intensive technical training will cost each participant an additional \$1700 for workshop tuition. Volunteers have an opportunity to complete the required training this year on August 5-August 30.

To find out more about EAA please see *Home Power Magazine* issue #41.

For background information about SEI please see *Home Power Magazine* issues @21, 31, 32, 49 & 50.

Solar Energy International

PO Box 715, Carbondale, CO 81623

970-963-8855, Fax 970-963-8866 • e-mail: sei@solarenergy.org

Homepage: <http://soltice.crest.org/renewables/sei/index.html>

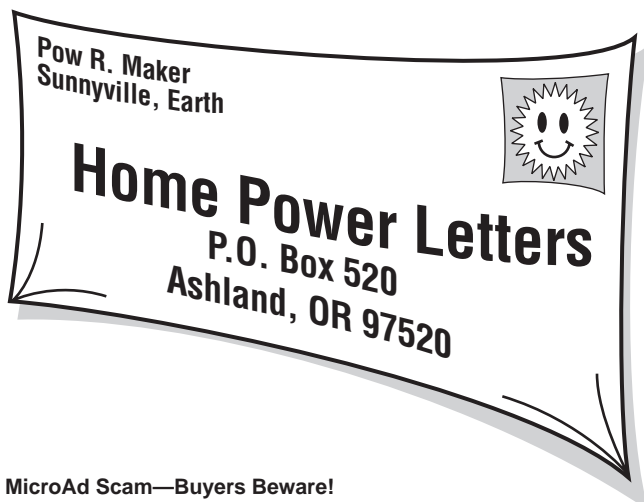

MicroAd Scam—Buyers Beware!

I am writing to inform your readers of a Scam that is being done on Home Power readers in the Micro Ads.

An ad for a Trace SW4024 was advertised in the micro ads in the June/July issue. On June 1st, I called the number 818-265-8443 and I received a recorded message. After leaving my name and phone number, I received a call back from a person calling himself Brent Geery. He said he had a project where a man wanted the equipment and after he bought it he backed out of the deal and now he needed the money so he was selling it for what he had in it.

He also said that I should send him postal money orders for my protection. He called on Monday June 3 to find out if I sent the money. The next day he called back to say that the post office did not have enough money to cash the postal money orders so he had to deposit them in his bank account and they wanted a week for them to clear.

After waiting a week I called back to see when he was sending the inverter and left a message on the recorder. Of course now he doesn't answer my phone calls.

While I got stung for \$1600, I sure hope that no one else did. If you did, please contact Home Power Magazine so we might catch this low life.

By the way, the US Postal fraud division says that they have had problems with Brent Geery since 1992. He uses the address: 5089 Highland View Avenue, Los Angeles, CA 90041. Thanks, P. F., Illinois

Well I guess HP has hit the big time and I sure wish we hadn't. Unfortunately as of today (July 4, 1996) three Home Power readers in Illinois, Missouri, and New Mexico have been defrauded out of \$1600.00 each.

I've spent hours on the phone with the phone company, the police, the post office and the California State Attorney General's office. I've learned a lot but nothing that will help the folks whose pocketbooks have already been hit. I discovered that the address, and I'm assuming the name, the creep sent with the ad is phony (Brad Smith, 5094 Parker Ave, Glendale, CA) and that he paid for the ad via an untraceable money order. All of the officials that I spoke with said that this type of fraud is rampant—buyer beware. The Postal Services' Fraud Division in Missouri told the gentleman from that state that they have known about Geery since 1986. The police in Southern California said that even if they had the time to investigate/arrest Geery the longest jail sentence he would serve was 60 days and probably no one would have their money returned. The Attorney General's office said to hire a private investigator—but then what? Hire Rocky?

We've been racking our brains trying to come up with ideas to prevent this from happening in the future. I thought that having something sent COD might work but none of the mail services allow

packages to be opened before money changes hands. Maybe if enough of us suggest this to the mail services they would consider adding that as an option. The two ideas that we have come up with are: 1) Buyer beware, if it looks too good to be true it probably is. Not very useful but unfortunately a sign of the times 2) Get serial numbers of the products and call the manufacturers to see if it is a real number and who originally bought the product. I've called several manufacturers so far (Trace, Heart, Ananda, Statpower) who said that would be happy to supply this information to HP readers.

After publishing for almost ten years Home Power is now being forced to require all ads from individuals to supply serial numbers for equipment that they are trying to sell via the Micros. I know this will make it harder for honest folks. I apologize for any inconvenience, but we must all work together to try to prevent future fraud.

Even though I'm afraid every time I answer the phone that I'll hear that its happened to someone else, please call us if this has happen to you or if you'd like more information. Karen

What's it worth? A Utility Engineer's point of view...

I read with interest your editorial in HP #53 entitled "What's it worth?" on page 4.

I'm an RE enthusiast, Home Power subscriber, and have a solar hot water system at home, a cost-effective and common way to use energy wisely in sunny climates like here in Hawaii.

As I'm also a utility engineer, however, I get a bit tired of folks placing energy issue blame at the utility doorstep.

Specifically, you'd mentioned that the Whitehead's utility paid them 1.7 cents per KWH, versus 10.5 cents per KWH retail, and that this was unfair. There are some sound reasons for this level of compensation. Please read with an open mind:

- 1) Utility businesses, like any other, buy or produce products or services at one price, and resell them at a higher price. The spread, less expenses, is profit. Happens with banks when they loan money, gas stations when they sell fuel, you name it. There's nothing wrong with this at the RE level, either. Why shouldn't RE power be bought from the Whiteheads, and sold to someone else on the grid? After all, the utility company has millions of dollars tied up in transmission and distribution infrastructure, and it therefore costs money to move power from A to B, whether B is next door or 100 miles away.
- 2) RE systems are not "dispatchable", meaning the utility has no control over someone else's input to their system. So, RE units cannot respond to system loading, which varies dramatically throughout the day. Meanwhile, their own units are fully dispatchable, and are computer controlled at all times to provide for grid reliability and stability.
- 3) RE systems are termed "as available" power, meaning non-firm. So, the power they produce is not always available to the grid. Therefore, the utility company cannot take their own generating units off line, even if their capacity is displaced by thousands of small RE systems. To do so would put the power grid at blackout risk.

Think of it this way: you go to the airport to catch a flight where the airlines have no set schedules. On a clear, windy day, there are plenty of flights. More, in fact, than are needed. So, you easily get a flight with plenty of empty seats. For the airlines, however, all those empty seats mean it's a money-losing day. On a different, cloudy and windless day, you again go to the airport. Same deal (no flight schedules). Only this time, there are very few flights. Passengers jostle with one another at the ticket counters; airlines are overbooked. You don't get a seat. And still the airlines lose money because they turned away thousands of willing-and-able to pay passengers.

These factors combine, in many cases, to make RE grid-intertied systems not such a good deal for the power company. In fact, the only benefit (savings) to the utility company are "consumables" (primarily fuel). This "avoided cost" is represented by the 1.7 cents per KWH paid to the Whiteheads by the utility.

I favor a compromise which closely approaches a “win-win”. As you know, California’s “net metering” law pays the small residential RE intertied system parity (retail) down to zero net use. Beyond that, RE systems are paid the avoided cost (low rate). This encourages RE systems, but doesn’t make all ratepayers compensate you for your equipment beyond what you need to displace your use.

This is a complex issue; ignoring the “other side” will inevitably bypass collaborative effort, leading to either a “win-lose” or “lose-lose” situation. In the long term, only a “win-win” is desirable or sustainable.

Thanks for listening! Andy Keith, Kaneohe, HI, Access: c/o Home Power Magazine

Hello Andy, and thanks for your criticism, which I will admit was justly deserved. You are right on several points. I'd never considered the grid as a stand-alone system that supplies the whole country at once. I realize that utilities are businesses and therefore dedicated to profit. I too favor at least net billing to parity for utility-connected, home power systems.

When I wrote that editorial I was angry, and I still am, that the Whitehead's need to generate six times more energy than they use from the grid in order to break even.

While America's utilities have thousands of lobbyists, paid-apologists, lawyers, and a hundred year working monopoly, all home power folks have is new idea—powering our homes with renewable energy. Over the past ten years, we've seen RE spread from rural stand-alone systems to the threshold of the grid. If RE is really to work for everyone, if everyone is to enjoy the benefits of clean and renewable energy, then I realize that the grid, or something very much like it, must exist. I know that energy made from renewable sources is intrinsically more valuable than energy made from non-renewable, polluting, energy sources.

I just want to see America's independent RE producers receive what they justly deserve. Avoided generation cost, which is based on the utility's cheapest power plant, just isn't fair because of what utilities call externalities. Little unplanned for expenses like nuclear accidents, nuclear waste storage, crop loss due to acid rain, oil wars, and nationwide health problems due to everything from atmospheric pollution to electromagnetic fields. These little externalities add up to over 200 billion dollars yearly (that's over \$700 yearly per capita). None of this money is billed via your electric meter, but instead concealed in taxes or paid out everywhere from supermarkets to hospitals. In terms of cents per kWh cost these externalities amount to 6.8¢/kWh for coal fired power plants, 3.2 ¢/kWh for oil fired plants, 1.2¢/kWh for natural gas fired plants and 2.9¢/kWh for nukes. Renewable energy has the following external costs: solar 0.4¢/kWh, wind 0.1¢/kWh and biomass 0.7¢/kWh, therefore I think RE is worth more. Information via Pace University survey 1990. Richard

Not Fair To Utilities

I am writing in response to your editorial “What’s It Worth” in Home Power #53.

First, a bit about myself. I am fairly new to HP (5 issues) and find the magazine very interesting and informative (I have particularly enjoyed the recent series on the “VoltsRabbit”, any more EV conversion articles lined up?).

Anyway, having just read the editorial (and the EV article), I would like say that, from the information you gave, It appears that the Whiteheads are getting a very fair price for their power:

(1. If, as you stated, “about half ”of the utility’s money goes into power transmission, then the price ratio drops to about 3.5. If it helps, you may prefer to think of the utilities paying 3.4 cents / kWh, but charging for the distribution. At least the Whiteheads don’t have to go out in ice storms, tornadoes, or whatever kind of bad weather is prominent where they live, to maintain their distribution system!

(2. Next, let’s talk wholesale. How much does a market sell 1 pound

of tomatoes for vs. what the farmer is paid? (I don’t know the answer to that one, but I suspect the ratio is comparable to the 3-4 figure). This is one reason for roadside vegetable stands, the farmer can make much more selling directly to the consumer (but he/she can only sell a small fraction of the total crop production in that manner). It would be nice if home power producers could follow this same model, but then how much more should they pay to use the distribution network?

(3. I am not much of a student of business, but it seems to me that monopolies exist for two reasons: either they can squash the competition, or competition is not economically feasible. In this case, the power monopolies seem to fall more into the latter class (distribution grids are vast, complex, and incredibly expensive). I’ll gladly pay the Whiteheads a whole 6 cents/KWh, all they have to do is get the power to me! (and guarantee 24 hour access and that they will provide all the power I want—you get the idea).

(4. Finally, with respect to your call to demand a fair price or unplug. I’d say you should unplug. The financial reality is that utilities can get along quite well without worrying about home power and if you expect them to pay you almost as much as it would cost them to generate the energy themselves, they are just as well off without you.

Anyway, just my random thoughts on the topic. I notice that almost all of the articles I’ve seen in your magazine have involve people with lots of land on which to build their systems (and other resources like water sources, etc.) Do you have many articles in the mill on urban projects (the situation that I am more likely to be in when I finally buy a home). I’m interested in energy saving designs, new technologies, and “urbanized” power. Of course with only a few issues that I’ve seen, there may be more there than I suspect. I’ll have to break down and spring for the Solar 1 CD soon. Robert Wood

Hello Robert. I should have included more facts and figures in that editorial! Energy is really much more expensive than your electric power bill might lead you to believe. See my answer to the previous letter by Andy Keith. In terms of using RE in the city, it is no different from using it in the country. You may have to mount you modules on the roof because of space limitations, but the roof is a big place—far more surface area than you need for solar access. Check out the cover story in HP#46. Vladimir and Elsie are doing renewables in downtown Chicago! All the info we publish about efficient appliances applies to urban use. Check out the index published in last issue. Look under “systems”, you will find urban systems marked as such in the index listings. I'd wager that most of our readers in the country don't have “lots of land”. We live and work on 40 acres here, and from most folks I talk to, this is larger than average. Our PV system makes about 1.8 kW and occupies about 500 square feet in our front yard. Richard

Paranoid Delusions...

I’ve been with you since #1, so I am obliviously sympathetic to your goals and style, but this kind of negative journalism smacks of paranoid delusions. You are anthropomorphizing utilities and imbuing them with human qualities of greed and deceit when the truth is more benign.

Any corporate structure is composed of the sum of its parts, all of which are normal well-meaning human beings just like you and I. This holds true for utilities or other for-profit corporations, government, or the most well intentioned non-profit organization. They do not function as a single organism, with a head that exercises free will and is individually driven by emotions and desires.

Such a corporate structure can, at best, be analogous to social insects, (ants, wasps, termites, etc.) with all of the strengths and limitations such as a structural organization implies. Each component of such a structure is an individual, doing its individual thing; but in the aggregate the whole obeys the inherent programming which has evolved with the structure. Ants bite, bees sting, and termites eat houses, but not because they are malevolent. They are just doing

what their inherent instructions tell them it takes to get by, feed, and reproduce.

Utilities (and other corporate entities) do the things they do—including paying 1.7 cents per kiloWatt-hour for 10.5 cents per KWH electricity—because they are programmed to maximize their return and minimize their cost. That is the nature of the corporate beast. It is a system which has evolved to turn human self interest toward the common good of society. Capitalism. It has gross limitations, but in the macro-view it seems to work better than any other system we have at the moment. If a corporation is not profitable it dies. No organism can allow itself to casually tolerate the threat of death and remain viable. Thus, just as in biological evolution, in business those entities which do not maximize profits at all cost died, leaving those who did to pass on their corporate genes to the next generation of MBAs. The whole process is a no-brainer. It's that simple. It's not viability of the Earth which governs, but the short term viability of individual "cells"—the "Tragedy of The Commons".

You CAN mess with the programming of corporate culture, but it is a hard job which requires dedication, knowledge, and persistence. Thus it is not a popular pastime. Your magazine does that. Your negative utility-bashing editorials do not. Delve deeper into the cause and effect relationships which you attack—and keep up the good work you are doing overall.

With you, I have observed the growth of the Alternative Energy industry from before your issue #1 to the present. There has been amazing progress and all signs point to some state of "critical mass" approaching in the near future. We are getting there, and your magazine has become the hub of the network helping to make it possible. "Damn the Utilities, full speed ahead!" and thank you. Clifford W. Mossberg, Kasilof, Alaska

I hear you, Clifford. I realize that most of the folks who work for utilities are just average Joes like the rest of us. In fact, my brother Michael works for the utility in San Antonio, Texas (see his article about the Grid on page 34 of this issue). I've no bones to pick with the individuals, but sometimes I wonder about the decisions made in the corporate boardrooms. Are these public monopolies motivated by the greater good and welfare of our planet and all who live on it? Or are they motivated by next quarter's profit? Even paranoids have real enemies.... Richard

What's it worth?

In a recent column, you pose the question "Is utility energy worth six times as much as PV energy?". The answer is, of course, no. When I pay the utility \$0.120 for a kW-hr of energy use, I am paying for:

- 1.) Generation 2.) Transmission 3.) Distribution 4.) Administration 5.) Profit

When I shoot a kW-hr of PV generation into the utility line, I am providing the utility with none of the other services, I am only allowing the utility to avoid the following costs:

- a.) Capital equipment for generation, including financing and construction. b.) Fuel costs c.) Maintenance of generation equipment. d.) Operating costs of generation, including retirement of old generation. e.) Purchase of energy from neighboring utilities.

The utility should pay for my energy in proportion to its own proportional generation costs. If generation accounts for 20% of its annual expenses, it should pay me \$0.024 for each kW-hr of PV energy I send down the line. In addition the utility should pay me the following premiums:

- i.) Increased efficiency of local generation over centralized generation (i.e., reduced line losses, which account for about 17% of a utility's generated energy). The farther a PV house is away from the rest of the world, the smaller this benefit to the utility. ii.) Reduced transformer operation, provided there are any customers on the same 240-v secondary as I am. iii.) Reduced T & D costs, in proportion to PVs penetration into the generation mix, deriving from deferred T & D upgrades (at this time infinitesimal). iv.) Any pollution

credits or avoided carbon taxes the utility enjoys by the presence of my PV energy. These utility benefits are not universal and would be infinitesimal on a house-to-house basis.

As for the many other benefits of PV, such as reduced military obligation for fuel supply protection, environmental benefits, employment opportunities, etc., the utility should pay me for these only as the utility enjoys the benefits. In the absence of legislation or regulation forcing the reflection of these costs in the energy bills of the utility's non-PV customers, the utility has no obligation to compensate me for their mitigation. To do so is not good business.

Present net-metering regulations are a short-cut to these two ends. The question is "What price for PV energy is fair to both parties?"

As a result of utility deregulation and the steadily shrinking relative costs of PV, the PV world and utility world are beginning to overlap. The next decades will see an explosion of opportunities for everyone in the PV world as well as for electricity consumers. You publish an excellent magazine. It offers a full spectrum of material ranging from field-proven technical instruction to well researched product information to the ramblings of an amusing (if sometimes enigmatic) Wizard. Now would be a good time to consider moving your editorial position on the utility world closer to the former and farther from the latter. Dave Lehmicke, Mobile, Alabama

Thanks for putting me back on track, Dave. I will be more tactful and fact full in the future. Richard

Of Carrots and kiloWatt-hours

Richard, I think you are unreasonably hard on power companies in your comments about net billing. Here's an analogy that expresses what I mean:

Suppose you sometimes grow more carrots than you need, and sell them to your local grocer, but sometimes buy carrots from him when you're short. You probably wouldn't expect him to pay you as much for the ones to sell as he charges for the ones you buy; he needs to pay his employees, his taxes, his mortgage, etc somehow, and a markup is the only way he can do it.

Now, on top of that, suppose you had signed a contract with the grocer saying that he must buy all the carrots you chose to sell him whenever you chose, whether he needs them at the time or not. Under those terms, he might sometimes have to turn down other, lower-cost carrots from somebody else who had a less confining agreement to avoid buying more than he could resell. The grocer wouldn't willingly agree to a but-all contract like yours without some extra inducement. In a free market, the inducement would probably be a lower price for your carrots, ie, a bigger markup.

Of course, you could lobby the government to pass a law saying the grocer had to pay you his full selling price for your carrots because you were growing carrots in a more ecologically sound way. That would be nice for you, but it would mean his other customers would have to pay your share of the grocer's expenses of doing business as well as their own. That's hardly fair to the other customers. You can say that the grocer should take the difference out of his profits rather than raising prices. Do you really think he would?

The analogy isn't perfect; there are differences in the quality of carrots, but not in kilowatts.

Don't get me wrong; I'm all for RE. I've installed six small PV systems for friends and am on the grid myself only because I'm living in a rented apartment. But in fairness, we should see the power companies' situation as well as are own. Six to one sounds like too big a markup, but I think some markup is only fair.

Keep on publishing. I like most of what you say and plan on subscribing in spite of occasional disagreements. David Coahran, Pullman, Washington

Another View

I almost didn't write this letter. However I was emboldened by your thoughts on grid inerties. It is my understanding that in an AE

system the power company requires that you buy power conditioning equipment you don't need (for your own system) to "clean up" your dirty wattage. Gag me with a Fluke 87 probe! In the one instance that I know of personally; a family spent over six thousand dollars to launder their dirty kw hrs. That however is not the worst of it, This is a wind based system, and they chose to power the windings in the charger with grid power!!! Guess who's house is dark when the grid goes down. This family spent forty-two thousand dollars on this system! Say that to yourself, "FORTY-TWO THOUSAND DOLLARS...." He proudly showed me the invoices. Ok Ok; maybe this is a worst case situation I'm describing here. It seems to me however, that if your system is sized correctly in the first place there'd be no point in interties at all.

To my way of thinking the decision to make your own power carries with it an inherent commitment to walk lightly on this over burdened eco-system we call home. A household that requires this kind of input to satisfy its energy jones could do with some sort of twelve step program, Nuf said.

Thank you for the great series on ac and DC electricity. We really appreciate this kind of information. Enclosed is our check for another year of Home Power. We feel that you and 'the crew' are contributing, in a vital way, to the evolution of the planet and its passengers. When you walk on a good path, all of creation moves to support your efforts. My wife Jennifer and I have been living with a stand alone system since we moved here from California thirteen years ago. Our home is a passive and active solar adobe built by Jennifer and I over the last nine years or so. The active part pumps solar heated water (from 12 second hand flat plate collectors bought from 'Smitty' at AAA Solar in Albuquerque. Great people!) through our floors in winter. We have a modest organic garden, a cistern (under construction) to catch roof run off. We wish to build a grey water system for the fruit trees. If anyone out there knows a good source of design and construction info we'd love to hear from you. We welcome inquiries or visits from anyone interested in PV, composting toilets, organic gardening, tree hugging, granola munching, etc. life. Write for directions or come to White Oaks New Mexico (pop. around 20) and ask directions. Ron and Jennifer Becker, Box 396, Ruidoso, NM 88345

Hello Ron and Jennifer. Thanks for your support. As a stand-alone system, we here at HP agree—just unplug. We've been off grid for 26 years now. Our direct contact with our local utility has been limited to opposing the construction of new high voltage, power lines through our rugged and wild neighborhood (Siskiyou Mountains of southwestern Oregon). About 16 years ago, the local utility proposed building a new high voltage line which would deliver Pacific Northwest hydro power into Southern California. Everyone in the neighborhood (over 300 folks most of whom were off grid) went to the power line meeting held at the local school house. The power company showed up and began by showing us a movie about a family going for a picnic. Where did the film family have their picnic lunch? Well, directly under a high voltage power line, of course. The crowd turned instantly ugly and the power company's people stopped the movie. What followed was an agonizing four hours of discussion which placed the power line in another, less organized, neighborhood. We didn't really win anything, we just passed the problem on to others. I still steam at the audacity of the utility, while pricing line extensions (we were then \$280,000 from the end of the lines) out of everyone's reach, the utility expected us to put their metal towers in our "back yard." Richard

Chernobyl

Dear Home Power, As a recent subscriber and having taken you up on your back issue package; I've been impressed with the quality and overall accuracy of your articles. Which is why I am writing to complain about Michael Welch's article on Chernobyl (Power Politics HP#53).

I am not a fan of nuclear power; but an article that contains several large errors with no documentation to back it up doesn't do RE any good. At best, you get called an extremist. At worst, you leave yourself open to legal hassles because you can't back up your claims.

Error #1. Mr. Welch doesn't document his sources. My main source for this letter is an article by Yuri M. Shcherbak. He was working as a medical researcher at the Institute of Epidemiology and Infectious Diseases in Kiev at the time of the accident and helped to treat the injured who were trying to put out the fire. In 1989 he was elected to the Supreme Soviet where as an opposition leader he initiated the first parliamentary investigation of the accident and cover up. He now serves as the Ukrainian Ambassador to the U.S.

Errors #2 and #3. He says he was appalled at hearing a news person say that only 30 people had died because of the accident; the 31 people who died were involved with the firefighting efforts trying to put out the blaze in the reactor core. This number deals only with the explosion and reactor fire itself. The long term death toll from the radiation release is currently estimated by Green peace Ukraine as being around 32,000, not the 125,000 Mr. Welch quotes. This is, however, a good estimate for the eventual number of long term cancer cases that could result from the accident.

Error #4. He actually understates the area that is contaminated. Mr. Welch lists 61,780 square miles; Mr. Shcherbak lists 260,000 square kilometers (161,556 square miles).

Error #5. Mr. Welch claims that the sarcophagus around the reactor has failed and has 11,000 square feet of holes in it. Mr. Shcherbak lists 1,000 square meters has cracked (approx. 3300 square feet). Mr. Welch also states that the reactor is the source of the contamination plume that is threatening the Pripjat and Dnieper rivers. Mr. Shcherbak lists the most likely sources as the 800 or so burial sites around the plant where debris from the blast was dumped into clay lined pits and buried.

Error #6 Mr. Welch says that the RBMK-1000 reactor at Chernobyl was "modeled after that of the General Electric Mark-1 reactor". The RBMK-1000 reactor is an adaptation of a military design used to produce plutonium for nuclear weapons. It is not a copy of a U.S. civilian design. He also states that the RBMK-1000's containment system is similar to the G.E. Mark 1. The truth is that the RBMK-1000 has no containment structure AT ALL. All U.S. reactors have large reinforce concrete containment buildings to guard against this type of thing. If Chernobyl had such a structure, it's doubtful that the explosion would ever have gotten out of the containment building. All the reactor at Chernobyl has for containment was a 2,000 metric ton steel lid over the top of the reactor vessel; apparently they relied on the weight of the cover to hold it in place.

Error #7. Mr. Welch claims the power companies are getting a free ride concerning the eventual disposal of spent reactor fuel. This is not yet the case. Since 1982, the nuclear power industry has paid in over 12 billion (that's right, billion) dollars into a Nuclear Waste Fund and related escrow account. This is what is to pay for building a permanent storage site for its wastes. The government has only spent 1.7 billion dollars so far at Yucca Mountain. (Chris Whipple, Scientific American, June 1996.)

As for his remark about what to do with the waste that has already been generated (i.e. leave it where it sits) it shows that he hasn't thought this out. He also contradicts himself from earlier in this very same article!!! He states that the Pripjat and Dnieper rivers are being polluted by debris from Chernobyl; then, later in his article, he states that we should let ours sit. Apparently he has failed to realize that every nuclear plant in the U.S. sits on a major body of fresh water. ALL OF THEM. They use the water to generate steam in the non-radioactive side of the system.

A good example is the one closest to me; Palisades (S.W. corner of Michigan, right on Lake Michigan). Because they are out of storage room for spent fuel rods, Consumers Power is now storing the rods

in concrete tubes on a slab with only a chain link fence around it, 100 yards from Lake Michigan. If there should ever be a leak, guess where this stuff is going to end up.

Error #8. As for his comment about hauling waste by 1998, Chris Whipple states in his article, "Can Nuclear Waste Be Stored Safely at Yucca Mountain?" (Scientific American, June, 1996) that even if they start digging tomorrow, Yucca Mountain won't be able to start accepting shipments until 2015.

Like I said in the beginning, I like Home Power because you normally print facts, not hype. Unfortunately, with the exception of his asking for help for the victims, that's what Mr. Welch's article was. Sincerely, Pat Howard, Cowell, MI

Pat: thanks for taking the time to respond to my column. I would like to point out that a column like this is not normally considered a place for bibliographical documentation. This is pretty standard in the editorial world, and not meant to deprive readers of access. Imagine how much room would be left in the magazine if we had to state the source of every bit of information published. That sort of thing is normally left to scholarly papers and topical journals.

However, we try to use "Access" at the end of each article where folks can go to get the information or more if they'd like. The Nuclear Information and Resource Service (Nuclear Information and Resource Service, 1424 16th St. NW #404, Washington, DC 20036, 202- 328-0002, Internet: nirsnet@igc.apc.org, <http://www.essential.org/nirsnet>) was kind enough to provide much of the info I used to report on the Chernobyl disaster.

I would caution readers that there are lots of discrepancies in information on this accident. Most of those who have had access to Chernobyl have been part of the industry whose main purpose is to promote more nuclear energy. We on the outside have had to take a close look at where information is coming from before we publish it. It is still possible that even among sources that appear to lack attachment to the nuke industry, discrepancies will exist. Remember, this is a country that was under totalitarian control at the time of the accident, and is still having troubles finding a democratic way of life.

The important thing is not so much that there are differences in opinion, but that this is a horrible accident that can, and will likely in my opinion, happen again. Let's not lose sight of the point because of squabbling about sources.

That said, let me elaborate on some of your points.

The television reporter I mentioned said, paraphrased, that "Thirty people died in the Chernobyl accident." At best, this is a misleading statement. At worst, it is a horrific cover up perpetrated on the public. In typical fashion, the nuclear industry denies that serious problems exist in their technologies. Keep in mind that two of the largest nuclear power plant manufacturers own two major TV networks, and the third is owned by a company not known to be pro-environment, to put it kindly.

While I respect Mr. Shcherbak, I used what I consider to be the appropriate organization in place to do this kind of estimating. The source for the death toll I noted in my column was an official estimate coming from Ukrainian Health Minister Andrei Serdyuk in April, 1995. Please note that in April of this year, that estimate was revised to be over 200,000 dead.

I suppose there is a lot of room for latitude in figuring the amount of contaminated land from the disaster, depending on what level of radioactivity you use to draw the lines. Truly, this was a disaster of global magnitude, and even the U.S. has seen measurable increases in radioactivity because of the explosion. Statistician Jay Gould and Dr. Ernest Sternglass have attributed some 40,000 premature deaths in the U.S. to the Chernobyl-caused radioactive cloud that drifted over this country in 1986.

There is just over three feet in a meter, so a square meter is approximate 10.7 sq feet, so your source's estimate of 1,000 square meters is close to agreement with mine. The tomb is definitely

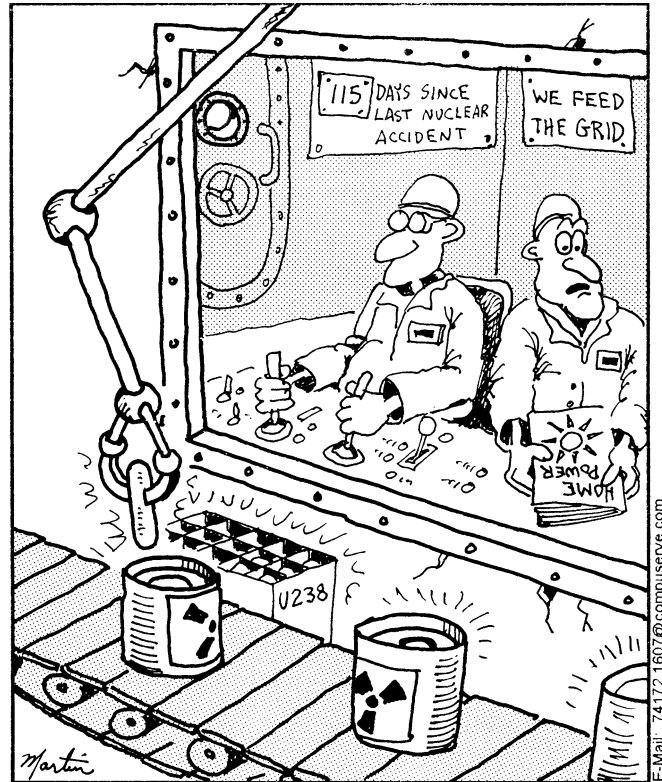

"According to this report, the safest thermonuclear powerplant is 93 million miles away..."

leaking radioactive waste, and it is disheartening to hear that the burial sites are leaking as well. Ukrainians say that a stronger sarcophagus will cost at least \$1.3 billion. A way to design and build it still hasn't been determined.

The Chernobyl reactor did definitely have a containment structure, although not the dome type structures we have all come to associate with U.S. nuclear power plants. The fact is that the explosion was so great as to breach both a vault with a humongous, 2,000 ton steel lid and the reactor building surrounding it. The General Electric Mark-1 nuke plant would also suffer in a similar situation. Because of fears that it could blow up its containment, Mark-1 reactors have been retro-fitted with a pressure suppression system that will vent to the atmosphere with as little as 30 psi of pressure. In a study of 24 U.S. nuke plant containments using the Mark-1 design, the NRC admitted that, "failure within the first few hours following core melt would appear rather likely."

I did not claim in my column that the "power companies are getting a free ride" concerning high level nuclear waste disposal. But, I did note that utilities want to get rid of the responsibility for that waste. Who wouldn't want to? But when you think about it, what difference does it make whether the taxpayers pay for it or the ratepayers pay for it? Either way, the citizens are picking up the tab and the utilities that are getting rich off nuclear power want no part of the long term responsibility for the waste they foist upon us.

Believe me, I've spent a lot of time thinking about the best thing to do with the high level irradiated fuel from nuclear power plants. From an engineering, safety, social justice, and environmental standpoint, it makes the most sense to leave the waste where it was generated. I firmly believe that it should not be allowed to contaminate other locations. On site, cask-type storage is not what I prefer, but it does make it much easier to monitor the condition of the fuel than any burying method.

Locally, we have a shut down nuclear power plant that still has all of its irradiated fuel on site. Even to us, it is preferred keeping it in our earthquake-ridden back yard over sending it off for someone else to deal with. Dry cask storage is the ultimate answer locally, but most plants without significant earthquake potential should keep their old fuel in their "spent" fuel pools. Too bad for them if they run out of room, the plants can just stop making more.

By the way, there are many plants that don't sit by large bodies of fresh water. As a matter of fact, none of California's four commercial nuclear facilities do. San Onofre, Diablo Canyon, and Humboldt Bay nuke plants all rely(ied) on salt water for cooling.

If Chris Whipple did, in fact, state "even if they start digging tomorrow", I would question the validity of his entire article on Yucca Mountain. They've been digging for years, and for quite some time have been working on the access tunnels with a huge boring machine that in a single pass cuts a path wide enough to drive a truck through. But, if everything goes well, Nevada will not be saddled with our nation's nuclear waste. Not in 1998, 2015, or ever.

No matter what the credible source each of uses, it is critical not to take our eyes off the prize. Simply stated, no more nuclear power. It is not safe, not environmentally friendly, and very, very hard on our pocketbooks. Michael Welch

Not Disappointed

I'm writing this after reading the "Disappointed" letter and reply in the June/July 1996 issue. I ordered a copy of the Solar 1 CD-ROM and am anything but disappointed. I like the simple ASCII format for back issues that was used—my text editor had no trouble reading the files. It's really great to have so much information in such a little package.

Improvement in the CD-ROM would, of course, be appreciated. But please also keep the simple *.txt files for those of us who are old DOS users. There is plenty of room on a CD-ROM for various file formats. Jerome Siegler, Jasper, Arkansas

I'm glad that you liked the ROM, Jerome. We're working on the new ROM right now and it will mostly be in the new Adobe Acrobat Portable Document Format (PDF). We've tried this format on a variety of computers and it works well. Files will be in full color and look just like they do in the printed issues. The text and art files are able to be copied and pasted into other documents. The files will also print on just about any printer. It's not ASCII text, but is this acceptable? Richard

Ammonia Absorption

I read with many concerns your article in Home Power #53, regarding making ice with ammonia absorption. There are many safety issues that need to be addressed before using ammonia, and as the Chief Engineer for an industrial refrigeration company, I have experienced many misapplications of ammonia. I have installed many large scale industrial ammonia refrigeration systems using compressors instead of absorption during the last 15 years, and ammonia is still the refrigerant of choice in our industry, if the system is over 350 horsepower. One of the reasons that ammonia is only used on large scale projects is due to safety devices that must be installed to protect people. A typical project can cost \$50,000 to \$100,000 in safety devices alone, which is required to meet the "Uniform Fire Code" and the "Uniform Mechanical Code."

Always use eye protection and gloves when handling ammonia. Black iron pipe as referred in the article is generally low grade water pipe with an ANSI designation of A120. This pipe is not acceptable for ammonia service. Always use A53 Grade B or A106 pipe, Schedule 80 thickness. Also remember, ammonia can reach pressures of 300 psig, but when liquid is trapped between 2 shut off valves and the liquid is heated further the hydraulic expansion can easily exceed 3,000 psi: (Now you have a bomb). I hope all of you backyard inventors seek lots of training and advice before you use ammonia. It is an excellent refrigerant, but must be respected. Gary Gneiting, Pinon Hills, California

Asko Love

I enjoyed your reports in April/May and June/July '96 issues on the Asko 1355 dishwasher.

I had been thinking of getting an Asko so last week I took the plunge. I had done some shopping and was able to find a 1355 for \$657. Plus tax. The distributor has a rebate program so the final cost was \$607.

So far my only complaints have been with the instructions. The installation instructions are nearly worthless, except to laugh at the bad English. I still need to pull the dishwasher out again because I didn't realize (and the instruction did not tell me) that the cabinet attachment screws are much further back than is typical on American dishwashers. The thick lip on my counter top does not extend back far enough for the screws to have something to screw into. Until then we have to watch pulling out the racks so that it doesn't tip out.

My wife loves the Asko. It is very quiet. It has removed much of the hard water film that was collecting on our glasses. She is also much more comfortable with the sanitation of our baby's dishes. We run it once or twice a day. If you do not let the dishes pile up before washing then there is little need for pre-rinsing only scraping. The instructions do not recommend rinsing, only scraping. If you are not going to wash for a while, then use the "Rinse and Hold" cycle. Pre-rinsing mitigates much of the water saving.

We use the water heater option. Since we have a tank-type electric heater it seems to be more efficient to set the water heater thermostat low and just heat up the dishwasher water to the higher temperature required.

I got a brochure on Asko clothes washers and dryers. Very interesting. Maybe for our house we are planning. We will probably be on-grid but very high efficiency. Maybe some generation capability (PVs?) with a utility intertie.

I enjoy the magazine immensely. I sometimes think there is a little too much emphasis on electricity production and consumption and not enough on other energy forms. I have a problem with people who can solve all their energy problems with a big enough tank of propane. Bob Farrell, Houston, Texas

Hello, Bob. Thanks for the feedback on the Asko. I know that many off grid folks, who make their electricity with RE, are also big propane consumers. Appliances such as water heaters, space heaters, cook stoves, refrigerators, and even engine/generators are all being fueled by propane. Water and space heating can be done with direct solar thermal energy. Cooking can at least be supplemented by solar ovens. While we at HP use these sources, we are far from experts. How about it readers? Does anyone have hard info on reducing propane consumption? Richard

Good Work in Vermont

Hello! Congratulations on producing such a fabulous magazine. From your layout to your content to your sense of humor you're bring excellence to the world.

My fiance and I are planning to be off-the-grid or energy independent some day in these beautiful green hills and your mag. is of great inspiration and help. We especially enjoy articles on hydro-wind systems and conservation building and heating techniques.

We are both presently VISTA volunteers for Project Warm Winter. Our goals are to establish energy-use plans for our areas helping small towns provide fuel/energy assistance for those that can't meet their winter heating needs. Any information or suggestions you could provide on low-cost energy efficiency techniques, or Vermont contacts in the RE and heating fields you could share with us would be greatly appreciated.

Regarding articles in Home Power, we'd love to see an investigation into an electric snowmobile. I saw an article on the electric motorcycle and thought the retrofit could be done on a snowmobile, true? Also, more articles on heating systems like masonry stoves

would be cool. In addition, we were wondering about how off-the-griders communicate. We assumed if there is no power line there is no phone line either, if this is the case what do you do? Go without? What do you guys there at HP Central have to connect electronically with the world outside your woods? Thanks. Andrew Perchlik, Brandon, Vermont

Hello, Andrew. We use a radiotelephone system here at Home Power. It spans six miles of space between our home/office and the nearest accessible phone hardline. The system is powered on both ends by two PV modules and each end has its own battery. We've been using the OptaPhone+ made by Carlson Communication in Garberville, CA. With power system equipment, the whole price tag was about \$5K. The system allows us to use normal phone appliances. We run a FAX machine, an answering machine, four telephones and three computer modems on this single line system. We are going to be expanding the R/T in the near future to handle two lines. Since we use the phone so much, owning our system is very cost effective. If you only use the phone a little, then cellular may be more cost effective. Before we had an R/T here, we used both ham radio and CB radio as telephone substitutes. These services work only if there is a neighborhood net and someone on the net has a telephone and is gracious enough to handle traffic for the phoneless. Richard

People That Work

About a year ago my wife and three children and I moved to southern Oregon. Much to our delight, we had discovered a secluded property above Rogue River where we intended to make our new home. One of the many obstacles we had to overcome was, our new found prize was 2.5 miles and \$50K from the nearest power line. I am happy to report that a year later we are living our dream. We have completed two structures and the main house (subterranean) is now under construction, all powered by renewable energy. I owe a debt of thanks and gratitude to Bob Maynard of Energy Outfitters in Cave Junction, OR whose patience and honest information was invaluable in helping me assemble "Ray's Power & Light." I am gratified to see many of the products incorporated into our system (the Heliotrope "PWM" series charge controller, Trace SW4024, and most recently the E-Meter), featured in HP's "Things that Work"!

Have you ever considered a feature on "People That Work"? This industry abounds with many good dealers, but the bad ones are out there too. I was lucky, but I continually read stories of others who are not. I know through my dealings with Bob & Golda Maynard that they have a very interesting story to tell. And, I am certain folks I have met along the way, Bob-O Schultze, Don Harris and others, have equally interesting stories to tell.

Thank you for an insightful and informative publication. Ray Ogden, Rogue River, OR

Hello Ray. We've tried to keep the content of Home Power technical and useful. How about it readers, would you like us to publish some personal profiles of people in the home power industry? I know these people and their stories contain much useful data, although it's not the kind you can draw on a schematic diagram. Richard

Better & Better

We have been living for over four years on our new site—off grid. With little increases and changes from time to time, our system works better and better. We hardly ever use our generator any more. All of this was made possible because of the information and inspiration provided by Home Power. Sam Russell, Craftsbury Common, Vermont

Thanks for the flowers, Sam, and we're pleased to have helped.

Port-au-Prince Power

Living in the mountains above Port-au-Prince, Haiti provides for many interesting experiences, but regular supplies of electricity and water are not included. At the moment we are doing "relatively" well, getting 6 to 8 hours of current per day (often 11 am to 5 pm) but in

the past few years we have gone weeks between shots of juice. But the sun shines on and we have now built our system up to being almost enough to sustain us. A few more batteries (next month) and few more panels (later in the year) and we will (with lots of care) be able to survive with no grid. It will probably take another couple of years to afford and finish the water heating system and install a solar tracker. I love the magazine and read every issue cover to cover. Keep up the good work. D J Farquharson, Port-au-Prince, Haiti

Seafood Pedalling

Thanks for printing my article in Go Power. I've had much positive response from friends, and quickly gave away the complimentary copies you sent. Enclosed is a check for more copies.

Also I received interesting feedback from readers: a paraplegic in Seattle who gets around in an electric motorized wheelchair planning to use PVs for battery charging, a young college student from Denver planning to kayak in the NW this summer and seeking info on the Willapa Water Trail, and a couple from Brunswick, Maine who farm oysters and do a lot of cycling and paddling. Great connections.

Thanks again. Keep up the good work. Gratefully, Larry Warnberg, PO Box 43, Nahcotta, WA 98637

Hey, Larry, we're glad to help. Perhaps the best thing about home power is all the great people we get to meet! Richard

Get a job

I'm writing you, not only because I am impressed with your magazine, but because you might be able to help with some career questions. I have an interest in the solar power field, but no work background in that field. How could I inquire about job/career paths in the field?

There are not many solar power companies in the Beaverton, Hillsboro, Tigard, Gresham, and Portland areas. Would I have better success if I looked/inquired further south?

Best of success with Home Power Magazine! It is quite inspiring! Ed Rauw, Beaverton, OR

Well, Ed, jobs exist in the RE industry at three levels. First is equipment manufacturers or OEMs. OEMs are generally larger companies such as Siemens or Solarex, and finding a job there is much the same as applying for employment with any major corporation. Smaller OEMs, such as Heliotrope, Trace, and Sun Frost, are more relaxed, but want the same thing as a larger corporation—education, experience and drive. OEMs in this field are looking for folks with college degrees in everything from computers and marketing, to electronics and electrical engineering. A second area for employment is distributors. Here you need organizational and sales skills. Jobs at the distributor level are more difficult to find because they are fewer in number. The third employment area is dealer/installers. Here hands-on knowledge is essential. Most dealer/installers want you already trained before they will hire you. If you don't have hands-on experience in PVs, batteries and such like, then go to Solar Energy International and get some. Once you have identified at what level you wish to work, it's a matter of contacting your perspective employers and knocking them out with your qualifications and willingness to work. We provide a database of over 1300 companies, on all levels, working in the RE field. You can download this database for no charge by calling the Home Power BBS at 707-822-8640. Richard

In-boxes

All of us at the Solar Energy Lab at the University of Wisconsin love to see your magazine circulating in their "in-boxes!" Pat Quinlan, Solar Energy Lab, Madison, WI

Hey, Pat, thanks for the smiles. We do our level best and it feels good to be appreciated! Richard

Constant Power

I really appreciate the "basic education" articles. We are new to RE, and enjoy the freedom it provides. I paid my last utility bill Sept. of 94

and I can't say I've missed the bill or the regular power outages. I haven't had one unplanned outage in nearly two years!

I would gladly increase my subscription rate if you could publish monthly. Judy Criswell, Chiloquin, Oregon

Sorry, Judy, no chance of us going monthly without going public or some such for the capital. We've tried to be self-financed and organically grown. Doubling our output would require four times the staff, two times the ad revenue and doubling our sub cost. We'd prefer to print only the best and take time to present the info in a bug-free fashion. This all takes time and people power. Richard

Students Needed

As an educator of alternative energy technology, I am pleased to find so much information readily available. The resource ads are invaluable when searching for suppliers. I need to have an article or information line on how to get more people in an urban area interested in alternative energy. Our program is flagging to the point we'll be minimizing the offerings if we don't get more students. Please give us some ideas or help. John Morris, Professor, Energy Technology, 50 E Grove St., Monroe, Michigan 48162

We are into promoting academic and hands-on institutions who provide education and training in renewables. We've printed your address so folks can directly contact you. I think that active demonstrations of RE work well in the city. For example, check out the Sun Chaser portable PV system on page 30 of this issue. Solar hot water works great in the city just like in the country and it saves money! Consider class projects to be used as portable demo systems for public events. Richard

Since the Wheel

I like most every article I read in Home Power Mag. Would like to see more wind generators and solar systems—photovoltaic is the best invention since the wheel, we must keep up the pressure on congress—so that this country will move into a #1 position in solar energy. Keep up the good work at Home Power Magazine. Mike Richmond, Twin Peaks, California

Hey, Mike, America is already far behind countries such as Germany, Japan, and Switzerland when it comes to government support and popular implementation of renewable energy. If we're going to catch up on the most important energy development of the century, we need to go into overtime with R&D—improving the PV making process so that they are cheaper and longer lasting. If we don't do this, then someone else will and we'll wind up buying from them instead of making it ourselves. Richard

Straw Bale Housing

We just moved into our new straw bale home, that we have been building ourselves for the past year. I saw it first in Home Power issue #35 "Straw and Solar a Perfect Renewable Match." I was inspired to research further. We got the info we needed from "out on Bale" in Tucson, Arizona. Now I look forward to further Home Power articles for info on solar hot water systems and the latest info on PV and wind systems. Keep up the good work. Jon Haeme, Kematon, Illinois

Thanks for the flowers, Jon and think about writing up your straw bale home. Karen and I have been dreaming of a larger building and we're very interested in what straw can do. I know, from the mail here, that our readers are interested also. Richard

Article suggestion

After looking at your last issue and seeing another lengthy story (which was quite good) on the basics of electricity, I find myself wishing I could see an article on the basics of a whole system. I'm not qualified to write this, so let me share with you what I have in mind.

First, a general diagram of a typical system. The diagram would show graphically where all the components fit in the overall system, including where physically each component can/should be installed.

Second, the text would explain the details of each component including its function, operation, maintenance, etc.

Third, start outlining general design hints, such as "If you are setting up a NiCd battery you should use PVs that produce X voltage." Also include which equipment works best together and whether some equipment on the market performs two or more of the basic system functions.

The basics would probably fit together nicely in one article, but the additional design hints, etc. may have to go somewhere else. I don't remember seeing such an article, but I'd sure like to.

This sounds like I'm asking you to make all your readers system designers, but this is not my point. Many people might use this type of article for that reason but the majority of your more novice-level readers need this info so they can understand what their system designer/installer is telling them.

OK, here's a little onion: in the last issue the IPP column indicated that there were 139 members. I really question the need to take up valuable space in HP for a column in every issue devoted to 139 readers out of the 10,000+ that probably read HP. I know your heart and heritage is with these people, but I feel the space in the mag would be better used by articles as I've requested. Just my opinion.

Over all, you're doing a great job and I thank you for every ounce of effort you put into the HP project. Keep up your energy and your excellent work. Jim Reiman, Grants Pass, Oregon

P.S. We're selling our place in Grants Pass and moving to Arizona—a lot of alternative energy needs to be developed down there!

Hello, Jim. Great idea for an article and I'll start writing it! While IPP may have only 139 active members, they represent every home power system. Their work is important, effective, and more folks need to be made aware of it. Currently our circulation is just over 18,000 copies per issue (half to subscribers and half sold on newsstands).

We are at critical period. We are making the energy decisions now which will shape the next century. If we leave the politics of energy up to the utilities, then we deserve what we certainly will get—another century of "we make it and you rent it." Richard

Mangled mail

Dear folks at Home Power

I don't know if this just my post office's problem, but each issue I've been receiving lately is a little more "chewed up." Issue #52 arrived with about 20% of the front cover missing! I'd rather have the back cover chewed. Can you put the mailing label on the back? Kelly Manzer, Fort Jones, CA

Kelly, We resent issue #52, so you should receive it by the time you read this. Unfortunately, we get several complaints each issue about similar mangling. There's not much we can do about it without stuffing every magazine in an envelope before mailing, and that would break our bank. We charge a little more for First Class Mail subscriptions, and all of those go into envelopes before mailing.

We can't really put the labels on the back of the mag, because the back page advertisers expect that nothing will be pasted over their ads.

A good start from your end would be to file a complaint with your local postmaster in hopes that he or she will pass it up the line. Karen

Solar B&B

Thank you for the free sample. My check for 1 year's subscription is enclosed.

In your May 1996 issue you asked readers to tell you what they would like to read about in future issues.

I own and operate a 5000 acre ranch in the beautiful hill country in Rio Frio, Texas. We operate a bed and breakfast business and would like to use solar for the new lodges that we plan to build. We are

unable to find out how this is done and how cost-wise we could use solar for heating and cooling.

Your assistance in helping us to find books available or other magazines would be a great help to us. Thank you. Carl Detering, Rio Frio, TX

I'm with you Carl, I wish we could run more info on passive (and active) solar space heating, solar hot water, and high performance, earth friendly housing. I put out a call to readers—how about contributing info on these subjects? The HP Crew is now almost entirely populated with electrical nerds. We need thermal and construction nerds! Richard

Lead Acid Restoration

RE: "An Account of Lead Acid Battery Restoration Using EDTA Tetrasodium", by Jon Kenneke, issue #52. You tested the hard-to-get EDTA tetrasodium but I am surprised you didn't test Cadmium Sulfate which is the battery rejuvenation product being sold in most auto parts stores and mail order (J.C. Whitney, etc.); such as VX-6 (National Dynamics Corp.), Electro Start (Victor Automotive Products), etc., as well as private label. Cadmium Sulfate seems to work, Cost \$1.80 to \$3.50 per bottle to recharge one battery. P A Jensen, Jensen Beach, Florida

EDTA tetrasodium salt offers the same performance at a small fraction of the cadmium sulfate's cost. The storage batteries used in home power systems are large in size (often 40 gallons of electrolyte or more). While EDTA tetrasodium would cost less than \$50 to desulfate a battery of this size, the commercial products would require over \$300 worth. Cadmium is also an environmentally sensitive material—we don't need anymore distributed around the planet, even in chemical combination with something else. Richard

Old PV Problem

On a ranch in Belize, Central America I have eight Photowatt 55 watt panels which saw service for about five years in the intense tropical sun. They have been in storage since 1987 and I am getting ready to put them back up.

The problem is their termination. The foil matrix which services as a conductor to tie the cells together electrically ends at a foil pad which seems to be attached to the glass face. Behind this is a layer of thick sealant plastic which has turned somewhat brown or cream over the years. The attachment terminals appear to be inserted through this pottant to bear against the foil pad, and appear to be epoxied in place.

The problem is that the mechanical forces associated with tightening the screws on the panel attachment terminals have caused the terminals to loosen and apparently pull away from the foil. I have emphasized the apparent nature of my observations because circumstances did not allow a resistance check for continuity between both terminals on the damaged cells, nor an electrical

output check, but the terminals are fastened (epoxied?) tightly to the backing and this backing membrane has pulled away from the glass in the area where the epoxy attaches the terminals.

In the winter of 1996–97 I will go back to Belize with the testing equipment to check electrical output of each of the damaged cells. Assuming there is structural damage to the termination—there is no damage to foil, cells, glass, or support frame—I need to be ready to repair the problem and it is unlikely I will find the materials or expertise in Belize to do so. Photowatt produced its last solar panel in the United States around 1982 so I cannot turn to them.

I thought to use a Dremel type tool and carefully cut/grind away the epoxy which attached the metal post terminals to the backing pottant. After that I'm at a loss. Since the backing has pulled away from the glass/foil I cannot reattach the post to the loose backing. I either have to find a conductive adhesive to attach the terminal post to the glass/foil—not a particularly good idea for reasons of mechanical stress—or I have to reliably reattach the backing and re-ement the terminal post to all of this.

All of this is an assumption on my part that the terminal post is only held against the foil pad by the mechanical bond of the epoxy and backing. I do not know if that is so without opening the damaged modules up. My ignorance of the actual structure of the connection between the metal terminal post and the foil conductor is a compounding factor. In fact, once I cut open the damaged epoxy and backing I am committed, possibly without the right supplies on hand, to continue the repair. Here you have the dimensions of the problem.

I have 440 watts of orphaned, apparently healthy panels, except for this problem. Any help or suggestions? Clifford W. Mossberg, Kasilof, Alaska

Well, Clifford, the first thing to do is to actually test the modules before digging into their connections. The resistance measurement between the two output terminals is of no use and dangerous to your DMM (current produced by the module will hopefully blow the fuse on the ohmmeter portion of the meter). The best check for a module's electrical connections is short circuit current with the module fully in the sun. Most DMMs will measure 10 Amps DC or more, so you can put the DMM in DC Amps high range and short circuit the module through the meter. If there is a bad connection(s) within the module, then you will see little (less than 50% of rated) or no current. The connections between the J-Box and the foil traces (which are tinned copper foil) inside the module were soldered in the first place. If you find them faulty, then dig out the potting material (carefully now!) and resolder (use 60 tin / 40 lead solder with a rosin flux) the connections. We've used silicon RTV compound to repair the damaged potting material with good success. Check the current output first, then dig and solder if necessary. Richard

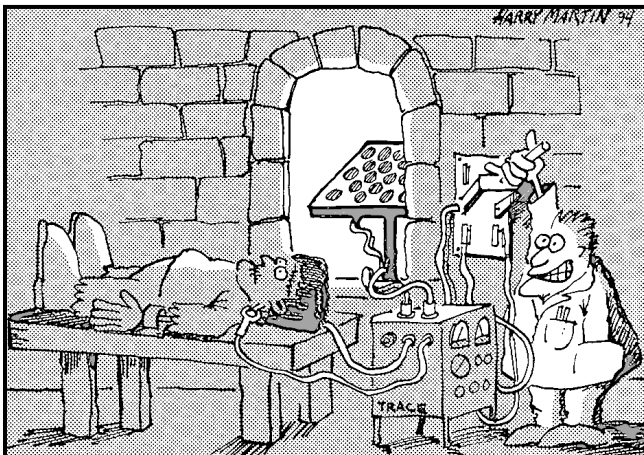

Need a renewable energy quick-start for the ole' brain?

Home Power Quick-Start Subscription Special

our last six issues, plus a one year surface subscription...

all for \$45 inside USA
(Call for International Rates)

Home Power Magazine
P.O. Box 520, Ashland OR 97520 USA

800-707-6585 in USA, or 916-475-0830

VISA or MC

Writing for *Home Power* Magazine

Home Power is a user's technical journal. We specialize in hands-on, practical information about small scale, renewable energy systems. We try to present technical material in an easy to understand and easy to use format. Most of our articles are written by our readers. Here are some guidelines for getting your RE experiences printed in *Home Power*.

Informational Content

Please include all the details! Be specific! We are less interested in general information, than in specific information. Write from your direct experience — *Home Power* is hands-on! We like our articles to be detailed enough so that a reader can actually apply the information. Please include full access data for the makers of equipment mentioned in your article. *Home Power* readers are doers. They want access data for the devices and products you mention in your article.

Article Style and Length

Home Power articles can be between 350 and 5,000 words. Length depends what you have to say. Say it in as few words as possible. We prefer simple declarative sentences that are short (less than fifteen words) and to the point. We like the generous use of Sub-Headings to organize the information. We highly recommend writing from within an outline. Check out articles printed in *Home Power*. After you've studied a few, you will get the feeling of our style. Please send a double spaced, typewritten copy if possible. If not, please print.

Editing

We reserve the right to edit all articles for accuracy, length, and basic English. We will try to do the minimum editing possible. You can help by keeping your sentences short and simple. We get over three times more articles submitted than we can print. The most useful, specific, and organized get printed first.

Photographs

We can work from any photographic print, slide, or negative. We work best from 4 inch by 6 inch color prints.

Line Art

We can work from your camera-ready art. We can also scan your art into our computers, or redraw it via computer. We usually redraw art from the author's rough sketches. We can generate tables and graphs from your data.

Got a Computer?

We would like your article's text on 3.5 inch computer floppy diskette if possible. This not only saves time, but also reduces typos. We use Macintosh computers. Please format all word processor files in "TEXT" format. We can also read text files on 3.5 inch IBM disks (720 KB, 800 KB, or 1.4 MB). Please format the IBM word processor files as ASCII TEXT.

You can send your article via modem to either the HPBBS at 707-822-8640 or via Internet. HPBBS address is: richard perez • Internet address is: richard.perez@homepower.org

Want your material returned?

Please include a stamped, self-addressed, return envelope, or box. Otherwise your material will not be returned.

Copyrighting

If you request it, we will copyright your work in your name. Otherwise we will copyright the information in *Home Power's* name. The copyright on your material is yours for the asking.

Got any questions?

Give us a call. This saves everyone's time.

Access

Home Power Magazine

PO Box 520, Ashland, OR 97520 USA

916-475-3179 voice or FAX

Internet Email via:

richard.perez@homepower.org



Q&A

Solar Orchids

I just ran into your magazine at the library. I grow violets and orchids. What will it take to grow these by lights? Power needs are about 1,000 watt bulbs (I have two of them). They are on 12 hours per day.

Does it make sense to use solar cells (or something else) to store energy to batteries. Or do something else. Thanks for your help, Charles Ohrstedt, Columbus, Ohio

Here's the scoop, Charles. If you have two lights, each of which consumes 1000 watts, and you need to power these lights for 12 hours, then you will consume 24 kWh per day. Assuming that you have a good solar site, this amount of energy could be supplied daily by 96 PV modules each costing around \$350. With batteries and controls, the system cost would be around \$40,000 which is a big chunk of cash.

Anyone know about a more efficient type of lighting for this purpose? A thousand watts is a hell of a big lightbulb! Richard

NiCd Refurbishing

I acquired 24 Edison NiCd ED-80 80 Ah batteries. Many of these cells had a grey sludge shorting the cells. I finally (after 4 years) found a place that would take the old KOH solution and the sludge. I cleaned the cells with water. The cells currently sit with distilled water covering the plates.

1. What is the proper solution of KOH?
2. A better question is, "What is the proper method of restoration?"

The cells will be used for pumping water when the power grid is lacking (which is often in the winter). The system I would like to use is: Use the grid to charge the batteries and the batteries to directly power the well pump. The well is 150 feet deep with a 120 gallon galvanized steel tank being pressurized by the pump to 60 psi. The current pump is long past due for replacement. It takes seven minutes to pump 60 gallons, it used to take two minutes. Do you have any recommendations either for a system or info? Thanks for your help. Ronald Deeter WB6FSB, American Canyon, California

Hello Ronald! You've already done the hard part on NiCd reconditioning—cleaning the cells and properly disposing of the spent electrolyte. Here's how to accomplish the rest of the process.

Safety first! Use rubber gloves and goggles! Have a supply of vinegar on hand in case you spill electrolyte on yourself. While alkaline electrolyte is not as fierce as the sulfuric acid used in L-A cells, it can still burn, especially if it gets into your eyes.

Mix the electrolyte using technical grade potassium hydroxide. Mix it into distilled water in a large plastic container. I use a clean 32 gallon plastic, heavy-duty, trash can. Keep adding KOH until the specific gravity of the electrolyte is between 1.2 and 1.22. This amounts to about one pound of KOH to one gallon of distilled water. Use a clean (i.e. never seen a lead-acid battery) temperature compensated hydrometer to measure the specific gravity. When the KOH dissolves, it will give off heat, so add the KOH slowly (about a pound at a time), mix thoroughly (I use a hunk of clean plastic conduit to stir the mixture) and wait for everything to cool off before making the specific gravity measurement. Mix all the electrolyte you will need at the same time if this is possible. This assures uniformity in the electrolyte. When the electrolyte is cool and at the proper specific gravity, then refill the cells. Add a thin (1/8 inch thick) layer of pure mineral oil to the top of each cell and you're ready to put the cells back in service. Expect the cells to take five or six cycles before coming up to full capacity.

On the well pumping scheme. You already have a fairly large pressure tank, so the question is what type of pump and inverter to use. I'd recommend an inverter/charger such as the Trace SW4024. It has a sine wave output, your pump will pump more GPM when powered by a sine wave. This inverter also has a dynamite, alkaline cell compatible, battery charger for automatically refilling the NiCds from grid power. I'd recommend using a 1/2 hp pump at 120 vac. We use a 1/3 hp, 120 vac pump (Franklin motor) here and it works great—less power consumption, but it pumps slower than the 1/2 hp models. Richard

Water Tower

I saw your issue #52 "Homebrew" for a home made wind tower. Do you have any plans (or know how I can obtain one) for a water tank tower, wood or steel? I have a 1400 gallon plastic holding tank that needs to be 16 to 20 feet high for gravity flow. Any information would be appreciated. Thank you, Phillip Donaldson, North San Juan, California

Well, Phillip, 1400 gallon of water weighs over 11,000 pounds and that's a lot of weight to support 20 feet above the ground. I think a better and far cheaper solution is to use an active water pressurization system. It works like this. A pump called a Booster Pump pressurizes the water by pumping it into a pressure tank. This is an active system powered by PVs and batteries. Use a large (120 gallon) pressure tank, not the little

dinky 40 gallon models installed on grid. Total cost of a system like this will be well below \$1500 which is cheaper than building a tower to hold your tank. An active system will also give you up to 60 psi pressure while the 20 foot tall water tower will only deliver about 10 psi. See Windy Dankoff's article about this type of water system in HP#39, page 20. Richard

Stereo Buzz

A long time ago I remember reading in one of your magazines about how to reduce the buzz of an inverter in a stereo. I remember the fix was installing a capacitor across the power supply. I know one of you will know what value to use and the location for the modification. Could you help me?

I have a Trace 2012 that is causing the interference. It is also causing problems with all the phones in our houses. All systems have a good ground What else can I do?? Rick, KD6VEG

We've run two articles with info on reducing telephone interference when using mod sine wave inverters. See HP#38, page 78 and HP#42, page 9. If you do the things recommended in these articles, you will have no more mod sine buzz on any of your phones.

Is your stereo powered by 120 vac (via the inverter) or 12 VDC from the battery? Both types have problems with inverter noise. The solution for the 120 vac powered stereo (or video) is a line filter. These filters come in many sizes and price tags. Start cheap with those sold by Radio Shack and if they don't work, then move up to a full blown power conditioner like those made by Sola. If the stereo is powered by low voltage from the battery, then add lots of capacitance (several hundred thousand microfarads) to the power leads right at the back of the stereo. The problem with the DC stereos is ripple (generated by the inverter) on the DC bus. This ripple feeds right on through the stereo's amplifier. Large amounts of capacitance will smooth out this ripple and render the stereo buzz free. Richard

Charge Controller Ratings

I hope you can clear up a problem for me. It started when I read an ad for the new Trace C-40 charge controller. The ad stated that the C-40 was a 60 amp controller NEC derated to 40 amps. My question is: are all controller ratings already derated, that is, is the Sun Selector 30 or Heliotrope 60 amp, etc. already derated or do you apply the 1.56 multiplier to them. I'm assuming you don't need to apply the multiplier to the Trace C-40. I would appreciate your clearing this up for me.

Thanks for a wonderful magazine. No matter what I have planned for the day, when Home Power arrives I find myself sitting down and reading it through. Also, thanks for the large print page numbers. Nothing is more annoying than reading the index of a magazine to find an article and then not being able to find page numbers to locate it. Keep up the good work. Don Fricker, Carbondale, Illinois

Yes, all NEC rated controllers are derated. NEC ratings are based on temperature. The published specification is the rated current. Both the Sun Selector and Heliotrope controllers are conservatively rated. For example, we use a 120 Amp Heliotrope CC120E controller here. I have seen this control handle of 160 Amps of current for short periods. It runs all day at between 120 and 135 Amps. Richard



Helio-Gram

June / July 1996

SOLPAN™

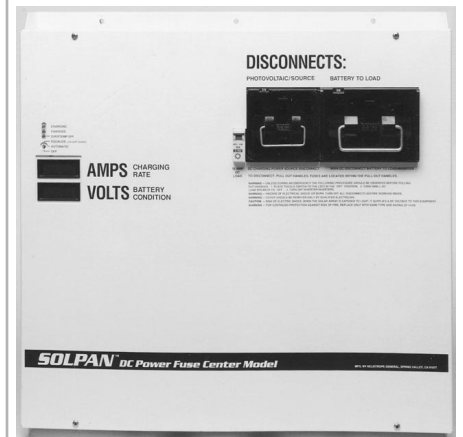

The Listed (ETL to UL 1741) power center with advantages

- Abundant wiring space.
- SOC set with DIP switch, no need for instruments.
- Two LCD display of Amps & Volts.
- No 120V AC in power center.
- Twin Fused pull-outs provide Proper fusing for charge controller and total disconnect.
- Inverter disconnected allows continuous PV battery charging
- Equalize switch on cover for easy access.
- Adding another inverter requires only adding one more fuse in pull-out
- Simple status lights from one board. 60 or 120 Amps, 12 to 48 Volts.
- Pulse Width Modulation from the proven leader in PWM technology.

Our products are available through leading AE Distributors & Dealers worldwide.

The name means reliability.

Heliotrope General
3733 Kenora Dr.
Spring Valley, CA
91977

Fax (619) 460-9211
(800) 552-8838
(619) 460-3930





Home Power MicroAds



Rates: 10¢ per CHARACTER, include spaces & punctuation. \$15 minimum per insertion. Please send check with ad. Your cancelled check is your receipt.

Help us prevent fraud! Home Power MicroAds from individuals must supply serial number(s) for equipment being sold. Businesses must supply a published phone number(s) and a physical address. If at all possible, please pay for your ad via personal or business check or credit card.

While Home Power is doing everything we can to prevent fraud, we can assume no responsibility for items being sold.

USED WIND GENERATORS, Towers, inverters, & Water Pumps: 80 systems in stock, 1500 Watts to 10kW. We repair & make replacement parts, blades & governors for most wind systems, pre-REA to present models, specializing in old Jacobs wind generators. We build tilt-up towers and tower-top adaptors for the Whisper Wind Generators. Best prices on Bergey, NEO, Whisper, & Windseeker. Plus we pay shipping to the lower 48. Call with your needs or write to Lake Michigan Wind & Sun, 3971 E Bluebird Rd, Forestville, WI 54213, 414-837-2267, Fax 414-837-7523

PURE CASTILE & VEGETARIAN SOAPS. Handmade in an AE environment. We also have hard to find natural bath & body care products. FREE catalog: SIMMONS HANDCRAFTS 42295 AE, Hwy 36, Bridgeville, CA 95526

HYDROELECTRIC SYSTEMS: Pelton and Crossflow designs, either complete turbines or complete systems. Assistance in site evaluation and equipment selection. Sizes from 100 watts to 5 megawatts. Manufacturing home and commercial size turbines since 1976. Send for a free brochure. Canyon Industries Inc., P.O. Box 574 HP, Deming, WA 98244, 206-592-5552.

LOW WATTAGE KIRBY'S (110 VAC) Rebuilt with 6 mth guarantee. As reviewed in HP#23 Home & Heart. & HP#32 Things That Work. 4 Amp/\$175, tools/\$25 UPS/\$25. SANDERSON'S 20295 Panoche Rd., Pacines, CA 95043 or (408) 628-3362

XXXXXXXXXXXX USED SOLAR MODULES XXXXXXXXXXXXXXX
XXXXXXXXXXXXXXXX 16-2000 - \$165.00 XXXXXXXXXXXXXXX
XXXXXXXXXXXX ARCO M51 — \$185 XXXXXXXXXXXXXXX
900+ Amp Hour phone batteries, cheaper than golf cart batteries — \$60 per cell. Absolyte II 865 AH 2V cell's \$100 each. Cruising Equipment new E-Meter \$179. Trace inverter 2512 \$1095. 1000 watt sine wave UPS 48V \$200, new 14 cu ft gas refrigerator \$1795, new & used ni-cads from AAA to 250 AH. Will match or beat anyone's prices on equipment. Call or write for free flyer. Craig, 10192 Choiceana, Hesperia CA 92345, 619-949-0505. Trade-in's welcome. M/C VISA Discover accepted

WATER PUMPING WINDMILLS for sale. Send \$5.00 for catalog. Muller Industries, Incorporated 1102 West 21st St Yankton, S.D. 57078 605-665-1924

AVAILABLE NOW FROM THE MIDWEST RENEWABLE ENERGY ASSOCIATION: Renewable Energy/Efficiency Directory. A great networking tool listing users, providers, networkers, educators and "do-it-yourselfers" in the RE fields. Send \$5.00 (includes postage and handling) to: MREA, POB 249, Amherst, WI 54406.

VERMONT SOLAR ENGINEERING — Over 15 years electronics & solar experience—Expert design & consultation, professional installation, sales & support, repair & upgrades — PV, Hydro, Wind & Domestic Hot Water. Do-It-Yourselfers welcome—price list available (sorry, no catalog at this time). Custom systems, kits & components at most attractive prices. Call Kirk toll-free, 1-800-286-1252, 802-863-1202(local), 863-7908(fax). PO Box 697, Burlington, VT 05402.

CEILING FANS: The largest selection of DC Powered (12 & 24VDC) ceiling fans anywhere in the U.S. From traditional to modern, classical to custom design. For brochure and list of dealers send SASE to R.C.H., 2173 Rocky Crk Rd, Colville, WA 99114. Dealer inquiries welcome FAX 509-685-0535

START YOUR OWN TECHNICAL VENTURE! Don Lancaster's newly updated INCREDIBLE SECRET MONEY MACHINE II tells how. We now have autographed copies of the Guru's underground classic for \$18.50, Synergetics Press, Box 809-HP, Thatcher, AZ 85552. (520) 428-4073, VISA/MC.

INTERESTED IN INTENTIONAL COMMUNITY? Communities magazine offers complete, updated listings of intentional communities not found in the Communities Directory. Practical information about forming/joining community — alternative buildings & structures; getting off the grid; # legal, financial & land options. Plus Eco-villages, Cohousing, decision-making, conflict resolution, successful communities, children in community, research findings on community living. Quarterly. \$18/yr, \$5/sample. Rt. 1. Box 169-HP, Louisa, VA 23093. (703) 894-5126.

WIND/SOLAR/HYDRO ELECTRIC SYSTEMS. New & Used Equipment. Propane refrigerators, lights, & heaters. Charge Controllers, Mounts, Meters, Battery chargers, Best buys on Inverters & Sun Frost refrigerators. New DC Compact Lights, Circuit breakers, Pumps, Low cost DC motors, Hydraulic Ram pumps, Coolers, Grain mills, Bed warmers, Tankless water heaters, Composting toilets, Low flush toilets, Fence chargers, Pocket tools, Solar cookers, Solar stills, Books, Shortwave radios. General Catalog \$4. Windmill Water Pumper/Hand pump Catalog \$5. DC powered garden tractors info packet \$6. Discount bulk foods Catalog \$3. KANSAS WIND POWER, Dept. HP96, 13569 214th Road, Holton, KS 66436 "Since 1975" 913-364-4407 Discount Prices!

MISSOURI'S DIGITAL Products Reseller. Off grid since '85, systems in Kenya, Madagascar since '86 seventeen years exp. in solar field. PV, Wind, Hot air and liquid Suncraft 4723 Tiemann St. Louis, MO 63123-5816 1-800-631-6732

EARTH-SHELTERED HOMES This definitive manual by noted authority Loren Impson features detailed building instructions for the amazingly affordable and practical Ferro-Cement Dome Home. Only \$15 from Sun Life P.O.Box 453, Hot Springs AR 71902

CONSTRUCTION PLANS AND ROTOR Magnet Kits Shipped Worldwide Since 1987. Don't let the experts rule your life — build your own brushless, low-revving power generator—from scratch! Let's be realistic, unless you own a slave, the only way to get a long-lasting generator for a windmill, water turbine or steam engine, with a decent output at low revs, without costing a small fortune, is to build it yourself. For seven pages of free info on the "Homebuilt Dynamo": get it now from my "home page" on the Internet (www.entrepreneurs.net/members/todd-forbes.htm) or from Al Forbes, PO Box 3919, Auckland, New Zealand.

APROVECHO RESEARCH CENTER offers 3 month training sessions in appropriate technology, sustainable forestry and organic gardening. Classes begin June, September, January (1 month in Mexico), March. Daily classes 8:30-5:30. Cost is \$500.00 per month, includes room, board. For more info: 80574 Hazelton Rd., Cottage Grove, OR 97424. (503)942-8198

STOP POISONING YOUR FAMILY, pets, livestock, home and our fragile environment with the Harsh Chemical laden products you are using!!! YOU Now have the POWER to DO something about it! Start using these Natural, Earth Friendly, Biodegradable and Totally NonToxic products Today! We have an Exciting assortment of Personal care products with pure Tea Tree Oil, a natural antiseptic, pain reliever and healing agent. Skin care products to protect your skin naturally. Health & Nutrition products that provide You with the right nutritional tools for Your body. Concentrated Home Care products to take care of Your everyday cleaning tasks + more! These products really work! The products and their ingredients are Never tested on Earth's Precious Animals. We really enjoy these products and so will You! If we all do a little, together, we can do A lot! Help us make a Big difference for our Fragile Planet! A portion of our Families profits as Independent Associates goes toward Renewable Energy Education! "Keep the Dream!!!" Distributors always welcome. Free catalogue & Distributor Info. The Silver & Bonnie Niewiadomski Family Homestead Farm, 102 River Drive, Plover, WI 54467, 715-344-0924

ORPHANAGE NEEDS 1 or 2 PV module lighting system. Praying for donations and help designing system. We know nothing, need help. John (618) 993-8357; in Uganda (256) 483-22193, Fax (256) 483-22636.

WIND/SOLAR ELECTRICITY generating equipment. Water/air heating. Catalog \$5. Staber 2300 Washers, Trace SW4024, SV modules, etc. Solar Creations 2189 SR 511S Perrysville, OH 44864 419-368-4252

FREE PROPERTY LIST for mountain land, some with creek or river frontage in beautiful Scott Valley, Northern California just 15 minutes west of Yreka off I-5. 5 to 320 acre parcels, perfect area for retirement or country lifestyle. Call Scott Valley Real Estate (916) 468-2252.

WINDCHARGER 32V 1500W, very good cond \$1000.00, Goulds pump jack \$150.00 11" brass steam turbine wheel \$100.00 Call Bernd (360) 354-5687 eves.

GLOBAL BOOKSTORE CARRIES Many Alternative Energy Titles. We stock books on solar & wind energy, hydroelectricity, electric cars, straw bale construction, underground houses etc. Large inventory of over 13,000 titles on Energy, Environment, Engineering, Computers and much more with same day shipment. To receive 375 page book/disk of complete database send \$10.00 to: United Techbook, POB 1658, Longmont, CO 80502. State IBM or MAC. To get a free search on any subject or price on any book in print call toll free 1-800-247-4808. E-Mail to utc@utcbooks.com Home page: URL <http://www.utcbooks.com/utc>

SOLAR HOT WATER SYSTEM Kits: Thermosyphon Design— Simple & Reliable— NO pump and controller— Perfect for Remote Homes— Complete Kit including piping, valves, New Stainless Steel 80 gal. Tank, Used 40 sq. ft. copper collector— only \$800 + freight & crating F.O.B. Escondido. CA (800) 564-0403

YOUR ALASKAN SOLAR EXPERTS! Complete source for Alaskan alternative power. ABS Alaskan, 2130 Van Horn Road. Fairbanks, AK 99701 907/452-2002, AK 800/478-7145 USED, SURPLUS AND DEMO Solar Equipment for sale at reduced prices. Inverters, Generators, Solar panels, Battery chargers and more. Discount prices on new equipment as well. Call or write us today for a free list of products, technical assistance or a free product or installation quote. 1-800-364-9941 Suntek, 303-C Creek St NE Yelm, WA 98597

THE BIBLE! INDEPENDENT ENERGY GUIDE—Electrical Power for Home, Boat & RV. Comprehensive, eminently readable, single-source guide for consumers, students & professionals. 282 pp, 7x9.25", photos/illus., \$19.95 + S&H (800) 639-4099 MC/Visa. Trade discounts available.

ELECTRIC POWER YOUR BICYCLE. Henthorn Regenerative Electric Auto. Simple Homemade Hydrogen. Plans catalog \$1. DWFrench, POB 2010(AEHP). Sparks, NV 89432

USED: Sencenbaugh 1000w, 12 v wind machine, controls, docs, needs blades, \$500; SCI 24v, 30a controller, t.c., \$50; Demo APT 3–24v, 200a Powercenter, \$750; New: SCI24v, 30a controller, t.c., \$75; Cruising Eq. AH+ 24v w/relay option, \$250; Solarjack SDS-Q-128 pump w/cntrl bx, \$650. all items freight extra. VT Solar 1-800-286-1252

LED ILLUMINATION: Ultra High Efficiency Light Emitting Diodes provide 10 times the battery life of incandescents. Flashlight \$10.95 (includes batteries). LED arrays, 5 diode unit 11.95, 10 diode unit \$17.95, 20 diode unit \$31.95. Larger arrays can be made on request. Red or yellow LEDs available. Units have essentially unlimited life. Free information. Noctilume, P.O. Box 7800, Fox Hills, CA 90233 (310) 967-4719

DESERT DWELLERS—Cool your home with 20 watts of power and a cool tower. See article HP#41. To learn more order the 68 min. video: Introduction To Cool Towers & Cool Tower Construction—VHS \$33.00 To: DAWN Productions PO Box 383 Vail AZ 85641-0383 (520) 647-7220

SOLAR ELECTRIC PANELS. new single crystal, 4" cells in glass and aluminum frame 100 watt (12 or 24 volt) 72 cells \$400 ea., 40 watt 30, 4" cells \$125 ea. (805) 373-9433

VERMONT DEALER. Come and visit my new well stocked and informative S.O.S. (shop, office, showroom) building in our off-grid PV and microhydro powered neighborhood. Helping do-it-yourselfers with free professional design advice for 9 yrs. Sales of new and used equipment, installations and service. Free educational workshops (see Happenings). Quality components at competitive prices. Trojan batteries in stock. Hot prices on Sun Frost refrigerators! Sale on Solarex VLX modules. Used TRACE inverters 2524SB \$700, 2524SB DVM ACTC \$900. Overstocked Inverters—new Power Stars, UPG 400W \$200, 700W \$250. reconditioned 1300W \$450. Westerfield AC mag ballasts for 2 pin CF's \$4.50, specify 13W, or 7/9W. Large supply of wire and cable. Overstocked and used controllers and meters. Independent Power & Light, RR 1 Box 3054, Hyde Park, Vermont 05655 call or fax David Palumbo 802-888-7194. No catalog requests please. Please call for appointment before visiting.

20 KW JACOBS wind generator for utility interconnect system on 100 foot freestanding tower; crated & ready to ship: New Equipment with original factory warranty: \$18,500 + shipping. 120 foot tower available for an additional \$2500. Lake Michigan Wind & Sun (414) 837-2267.

WANTED MULTIMEDIA Computer Nerd! Attend workshops for trade/work study 6–12 months. Get "hands-on" renewable energy training and help SEI develop digital presentation programs. ibm pc, net-savvy learning environment for right person. Contact: Solar Energy International (SEI), PO Box 715, Carbondale, CO 81623, 970-963-8855, fax 970-963-8866, e-mail: sei@solarenergy.org

FOR SALE: Photocopied reprints of Home Power issues 1–10 available after the Iowa Renewable Energy Fair is over. All proceeds will be donated to IRENEW. Call 815-469-5334 after Sept. 8, 1996. Sold only in sets of 1 thru 10 for \$30 which includes shipping.

DIRECT TO YOU SALE!!!! (no pickups on these items) Dometic (Serval) 7.7 cu. ft. propane fridge \$995; Trojan L-16, \$149; T-105, \$62; all items freight extra. VT Solar 1-800-286-1252

24V 2500W HEART HF24-2500X Inverter (serial#2132), in sealed box from factory upgrade. Instant, silent load demand start runs switchmode cubes in stby! \$700/offer 707-895-3837
USED STUFF: BEST M48–5000, IBE 24GPU375/SD, Various 1st & 2nd generation Heart Interface. ITA, Box 13168, Trapper Creek, AK 99683. (907)733-2515

SUNWORTHY SOLAR ELECTRIC has the lowest prices on new brand name products. Trace SW4024-\$2586/DR1524-\$812/Siemens PC4JF module-\$468/Siemens M-55 module-\$325/Solarex MSX60-\$400/Bergey 850w windmill-\$1,795/Windseeker 502-\$750/Trace C40, C30A only \$80/VISA/MC accepted. Call or Fax now for 120 page products and planning guide. (502)889-0624.

1800 JACOBS WIND Plant with 48' 3 leg tower. Also comes with a Fairbanks Morse 32V gen. Call Kirk @ (319)724-3522.

ELECTRIC CAR-'65 V.W. Needs much work—Not for inexperienced—no batteries—\$500—Wis. (715)442-2214

WHITE LIGHT ILLUMINATORS now available! Delta Light is the original—not a weasel copycat like others gives you another first! Send Large SASE for information. Delta Light, ICO PO Box 202223, Minneapolis, Minnesota (55420)

SURPLUS LEAD-CALCIUM Storage Batteries for solar or wind power storage. Many types from 100AH to 1500AH and 2V to 110V from Atlantic Battery, P.O. Box 172, Watertown, MA 02172. Delivery available anywhere in U.S. Call toll free: 1(888) DEEP-CYCLE.

SHOWROOM DISPLAY, new APT powercenter3, 12vdc, 35A PV control, (450watt PV array max.) 60A disconnect, digital monitor, breakers, cables, etc. \$556.00 + shipping, C.O.D. New in box, Midway Labs 260wp PV concentrator module array (requires a Wattsun tracker). \$1,206.00 + shipping, C.O.D. Call Cornette & Company Solar Cell Products at (813) 251-5915 or write: P O Box 3443 Tampa, FL 33601-3443

PUMICE SOLAR HOME in Taos, NM. Off the grid 2400 sq. ft. 3BDR/2BA SW style home on 5 acres of ponderosa & pinons overlooking entire Taos Valley. Completely self-sufficient in a very private setting. \$240,000. Call Pinon Investments of Taos 505-776-8106, POB 400, Arroyo Seco, NM 87514

15KW JACOBS WIND Generator Bought 3 years ago. 14'6" blades updated inverter 80' Rohn freestanding tower. Grid interconnect (Achavel Serial# MEPD-105-1086) Is up and running. 10,000 or B.O. 1-508-839-9547

FOR SALE: 91 Solectria Force, excellent condition, new Trojan battery pack, \$12,500 or best offer. Call Pete (617-326-3436 Boston

CATSKILL MOUNTAIN custom solar home, brand new, on 20 very private acres with pond, organic orchard, fields, woods and spring. Off the grid with a state of the art photovoltaic system. Copper Cricket solar domestic hot water system. Native bluestone arches and pine interior, huge beams, cherry floors, custom tile bath, full basement workshop. 20 minutes from Woodstock, New York. No brokers \$247,000.00 914-657-8096.

LEAD ACID BATTERIES and generator Twenty five 2 volt batteries in good condition. Each weighs 300+ pounds. 13" x 14" 30". 10 kW gas generator. AC/DC, 3 phase; \$4,000 for all. Call Bill at (206) 567-4411

BEST 5000W INVERTER w/charge controller—48Vdc to 240Vac or 120/120Vac \$900 (503) 658-8475



Index to Advertisers

- A.C.I. — 72
Abraham Solar — 59
Adopt a Library — 88
Advanced Composting Systems — 42
Alternative Energy Engineering — 47
American SunCo — 85
Ananda Power Technologies — 15
BackHome Magazine — 70
Backwoods Solar Electric Systems — 67
Better Building Systems — 70
Bogart Engineering — 43
BP Solar — 33
BZ Products — 75
C. Crane Company — 69
China Farm Machinery — 80
Communities Magazine — 78
Cone Construction — 33
Cruising Equipment — 1
Dankoff Solar Products — 14
DC to Light — 67
Delivered Solutions — IBC
Electro Automotive — 85
Electron Connection — 32
Energy Outfitters — 59 & 70
Energy Systems & Design — 67
Environmental Marketing — 58
Eros — 63
Exeltech — 43
Fools Crow Cycles — 63
Fowler Solar Electric — 47
Gimme Shelter — 85
Great Northern Solar — 95
Gyrokite — 25
Harris Hydroelectric — 39
Heart Interface — 1
Heliotrope General — 108
Hitney Solar Products — 42
Home Power Back Issues — 84
Home Power Biz Page — 81
Home Power CD-ROM — 58
Home Power Sub Form — 81
Home Power T-Shirts — 52
Horizon Industries — 79
Hydrocap — 48
Illowa Windworks — 88
IRENEW — 80
Jack Rabbit Energy Systems — 58
Johnson Electric — 79
Kansas Wind Power — 67
KTA — 51
Lake Michigan Wind & Sun — 25
Lil Otto Hydroworks — 78
Maple State Battery — 72
Midway Labs — 75
Moonlight Solar — 75
Morningstar — 10
MREA Workshops — 79
Northwest Energy Storage — 69
Offline — 85
Photocomm — BC
Planetary Systems — 43
PV Network News — 84
Quick Start REading Special — 105
Rae Storage Batteries — 75
Read your mailing label — 63
Sanderson's Rebuilt Vacuums — 80
Sierra Solar — 74
Simmons Handcrafts — 85
Snorkel Stove Company — 42
Solar Chef — 79
Solar Depot — 5
Solar Electric Inc — 72
Solar Electric Light Fund — 52
Solar Energy International — 21 & 96
Solar Industry Journal — 70
Solar Pathfinder — 58
Solar Quest — 70
Solar Village Institute — 63
Solar Works — 67
Solartrope — 75
Southwest Windpower — 21
Statpower — 48
Sun Frost — 80
SunAmp Power Company — 48
Sunelco — 25
Sunroom Consulting — 90
The New Electric Vehicles — 51
Trace Engineering — 11
Trojan — 10
United Solar Systems — IFC
Wattsun (Array Tech Inc.) — 33
Wind & Sun — 59
Windstream Power Systems — 47
World Power Technologies — 80





HOME POWER

THE HANDS-ON JOURNAL OF HOME-MADE POWER

ISSUE #54

August / September 1996

\$4.75 U.S.

\$6.60 CAN.

Display until October 1