

HEART INVERTERS AND  
CRUISING EQUIPMENT

full page  
four color

on negatives

this is page 1

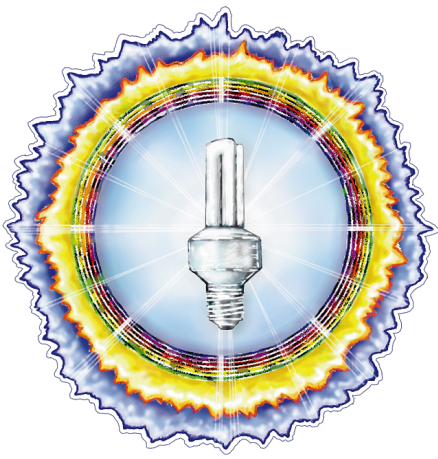

# HOME POWER

THE HANDS-ON JOURNAL OF HOME-MADE POWER

Issue #59

June / July 1997

## Features

- 6 RE Earthship**  
*Linda & Jeff wanted to do it themselves. So they did, and they learned a lot in the process. Here is their account of the successes and, well, learning experiences of designing and installing their own wind & PV-powered electrical system.*

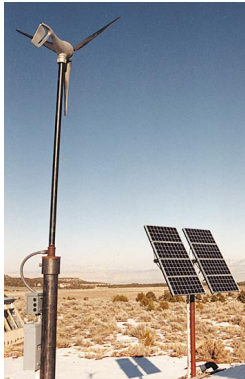

- 14 Hydrogen Storage**  
*Walt Pyle discusses the various methods of storing this potentially revolutionary energy source. Then he describes in "Homebrew" detail one of his preferred methods: Storage within Metal Hydrides.*

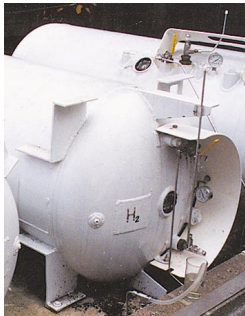

- 44 Solar Hydronic Heat... Cheap**  
*Chester Johnson & Joel Chinkes let us in on the simple and inexpensive method Chester used to warm his New Mexico home with solar heated water.*



## GoPower

- 56 Solar Boats in Minnesota**  
*School students have a great time competing in this annual regatta. And the organizing of the event is an accomplishment in itself.*



## GoPower

- 63 Rally round the EV**  
*Shari Prange gives us the scoop on some EV events anyone can participate in: tours and rallies.*
- 68 Getting Tired**  
*Mike Brown answers EV questions where the rubber meets the road: What kinds of tires to run on an EV.*

## Features

- 24 Grid Intertie Success!**  
*Jonathan Hill's PV system is intertied with PG&E. Net metering is the deal and all is going well. It can happen!*
- 30 Free PV in Mexico**  
*Well, not quite, but Dean Still and Kim Schramm were witness to a government subsidised residential PV project that seems to have been done right.*
- 50 Solar Yummies & Solar Dollars**  
*Laurie Stone and the Solar Energy International crew help a motivated group of women in Ciudad Obregon, Mexico build solar ovens and start their own bakery business.*

Cover: Linda & Jeff's system was a learning experience, you can learn from their difficulties. Story on page 6.

## Financial

- 36** **How to finance your RE system**  
*Dan & Lori Whitehead got a loan from their bank to pay for their RE system. You can too, if you follow these simple procedures for a professional presentation.*

## Things that Work!

- 40** **Morningstar Charge Controller**   
*A low price 12 Volt PWM charge controller, simple effectiveness.*

## Humor

- 70** **A Hydro Guy Rubs-It-In**  
*Robert Costello's hydro system has provided him with the means to loose sight of it all.*

## Columns

- 72** **IPP**  
*Utility restructuring and distributed generation defined.*
- 76** **Code Corner**  
*John Wiles finds dangerous multiwire branch circuits in his home. Also, wire types for use in RE systems.*

- 82** **Power Politics**  
*The history & successes of an anti-nuke non-profit: Redwood Alliance.*

- 86** **Home & Heart**  
*Excess power not used is wasted. Kathleen Jarschke-Schultze uses her extra in many ways.*

- 92** **the Wizard speaks...**  
*Review of a book on free energy.*

- 106** **Ozonal Notes**  
*Richard Perez rants and raves as Home Power revives this old column to let you know what's going on.*

- 114** **Index to Past Articles**  
*Listing of all articles which have appeared in previous issues of Home Power.*

## Regulars

- 4** **From Us to You**
- 80** **HP's Subscription form**
- 81** **Home Power's Biz Page**
- 88** **Happenings — RE events**
- 93** **Letters to Home Power**
- 108** **Q&A**
- 111** **Micro Ads**
- 128** **Index to Advertisers**

## Access and Info

### Access Data

Home Power Magazine  
PO Box 520,  
Ashland, OR 97520 USA  
Editorial and Advertising:  
phone: 916-475-3179  
fax: 916-475-0836  
Subscriptions and Back Issues:  
800-707-6585 VISA / MC  
Computer BBS:  
707-822-8640  
Internet E-mail:  
hp@homepower.org  
World Wide Web:  
<http://www.homepower.com>

### Paper and Ink Data

Cover paper is 50% recycled (10% postconsumer and 40% preconsumer) Recovery Gloss from S.D. Warren Paper Company.

Interior paper is recycled (30% postconsumer) Pentair PC-30 Gloss Chlorine Free from Niagara of Wisconsin Paper Corp.

Printed using low VOC vegetable based inks.

### Printed by

St. Croix Press, Inc.,  
New Richmond, Wisconsin

### Legal

Home Power (ISSN 1050-2416) is published bi-monthly for \$22.50 per year at PO Box 520, Ashland, OR 97520. International surface subscription for \$30 U.S. periodicals postage paid at Ashland, OR, and at additional mailing offices. POSTMASTER send address corrections to Home Power, PO Box 520, Ashland, OR 97520.

Copyright ©1997 Home Power, Inc. All rights reserved. Contents may not be reprinted or otherwise reproduced without written permission.

While *Home Power Magazine* strives for clarity and accuracy, we assume no responsibility or liability for the usage of this information.



Recycled Paper



Recyclable Paper

## What is Home Power?

## People

Linda Brotman-Evans  
Mike Brown  
Joel Chinkes  
Sam Coleman  
Robert Costello  
Jeff Evans  
Jonathan Hill  
Ralph Jacobson  
Robert Janssen  
Kathleen Jarschke-Schultze  
Chester Johnson  
Stan Krute  
Chuck Kurnik  
Don Loweburg  
Harry Martin  
Karen Perez  
Richard Perez  
Shari Prange  
Walt Pyle  
Tom Roark  
Benjamin Root  
Mick Sagrillo  
Kim Schramm  
Bob-O Schultze  
Dean Still  
Laurie Stone  
Michael Welch  
Dan & Lori Whitehead  
John Wiles  
Myna Wilson



Photo by Robert Janssen, Aspen, Colorado

### **Home power is an energy technology.**

We can make our own electricity and heat using natural energy sources—sunshine, wind, and falling water.

### **Home power is energy self-sufficiency.**

A home's energy can be produced on site, just like growing a garden produces food on site. We are free to live where we wish, far beyond the commercial electric lines. Our fuel source is free and delivered daily.

### **Home power is energy peacefully coexisting with our environment.**

Renewable energy technologies have virtually no environmental impact. There is no nuclear waste, no acid rain, no greenhouse gasses, and no dammed rivers. Home power means having good enough manners to graciously accept what nature offers us, when she offers it, and in the form she offers it.

### **Home Power is a magazine**

We have been publishing *Home Power* since November of 1987. This magazine is the hands-on users' journal of home-made power. We chronicle the doings of some 100,000 renewable energy producers inside the USA, and many thousand more internationally. *Home Power* is for sharing our knowledge of renewable energy.

We welcome your comments and contributions. By sharing knowledge, we all grow....

*Richard Perez for the HP Crew*

***“ Think about it...”***

***“Sad soul, take  
comfort, nor forget  
that sunrise never  
failed us yet.”***

***Celia Layton Thaxter***



# Solar Electric Systems

*For Remote Independent Living*

# UNI-SOLAR®

TRIPLE JUNCTION SOLAR MODULES

## The Next Step In The Development of Solar!

This solar module incorporates three separate layers of power producing material maximized to absorb different spectrums of light. These three layers, or junctions, increase overall efficiencies resulting in a more powerful, lower cost module.

- Lower cost
- Unbreakable Non-Glass Construction
- 10-Year Warranty
- Triple Junction Technology
- Shadow Guard Protection

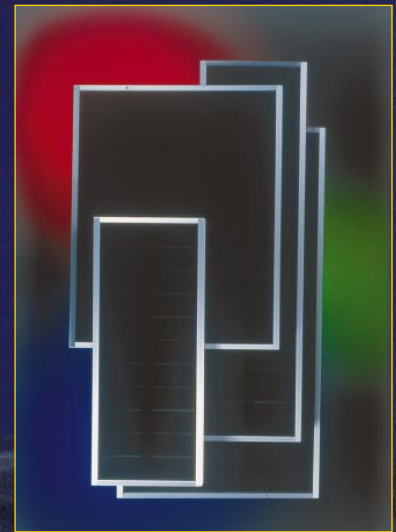

## Ideal for . . .

- Water Pumping
- Electric Fence Charging
- Recreational Vehicles
- Remote Cabins
- Battery Maintenance
- Marine applications

# Sunelco

THE SUN ELECTRIC COMPANY

100 Skeels Street  
Post Office Box 787  
Hamilton, Montana 59840

# 1-800-338-6844

**FREE TO  
HOME POWER  
READERS**

**132 Pages of Answers ...**

Our publication begins with basic load analysis and sizing information and includes case

histories, design guidelines and useful in-depth data required for system layout. It offers detailed descriptions of solar components and packages. A must for every energy library.

# ***RE Earthship Design: on-the-job-training***

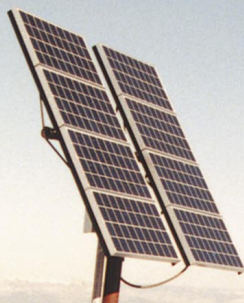

Linda Brotman-Evans & Jeff Evans

©1997 J. Evans/L. Brotman-Evans

**S**etting up a renewable energy home is a pioneering effort. There are many hurdles and much that must be known to avoid mistakes. It can be frustrating and more expensive than planned, but it is worth the effort. There is great satisfaction in realizing energy from the sun and wind, knowing that your energy use represents a clean and sustainable resource.

When we decided to build a home we hoped our energy system would meet our immediate and future energy needs. We made many initial choices and decisions, much like most novices. We read extensively, spoke to people, listened to their recommendations, and took our chances. If we had known how to better evaluate systems, our uses, and capacity, we would have made different choices in components, size, and system location. The most difficult part is the process of getting useful, clear, and accurate information leading to the right decisions in the beginning, not after you have made your investment.

We built an "Earthship" style home to serve as a self-heating and cooling, thermal mass structure. This eliminated the need for any electric energy for heating or cooling. Initially we installed a small solar system to reduce set-up costs. Our first year in the house began in November of 1995. We started with eight Kyocera 51 Watt multicrystal photovoltaic modules rated at 3.02 Amps and 16.9 Volts each. The array sits on a steel pole atop an earth berm on the north side of the house, about 21 feet high. The panels are as close to the power center as possible, approximately 20 feet. We rotate the panels by hand on a daily basis, usually setting for morning sun the night before, rotating later for midday and late afternoon positions. We also adjust for azimuth on a seasonal basis.

We installed ten Trojan T-105, 6 Volt deep cycle batteries, 220 Ampere-hour rated, and wired in series pairs for 12 Volts. We selected a Trace 2512 modified sine wave inverter, 2500 watts continuous and 6000/8000 watt surge capacity without battery charger. During our first winter we realized we wanted more energy. In March of 1996, we added an AIR 303 wind generator rated at 300 Watts. After we lived in the house for over a year we purchased a Generac 4000 watt gas generator with a Diehard 60 Amp battery charger.

What we have learned in the process is that for every system decision, you alone are responsible, much like designing and building your house. Information is available as are individuals who can help. All the reading and conversation, though, cannot fully prepare you for living with the system's benefits and limitations. If you make a mistake, have cold batteries, or see a change in energy production, you live with the initial and continuing decisions and responses. We call this "on-the-job-training" for novices. Mistakes cost you time, labor, and money while you learn. What you gain is independence.

Knowledge is picked up in bits and pieces, corrections and adjustments made as needed. Experience has shown us that most solar home owners require more energy than their systems supply. They continually add to their systems. Weather conditions here and around the country have become less predictable and more variable. This year, for example, we have had more continuously cloudy days than when we originally set up our system.

In peak sunlight our panels produce a maximum of 22 Amps. This translates to 371.8 Watts of actual production in optimum conditions. The panels are rated

at 51 Watts each, giving 408 Watts total. Actual production is less than rated by about 9%. At 20 Amps we have 338 Watts per hour flowing into our battery bank, an 18% decrease from rated production on an average sunny day. Actual performance then, is anywhere from 10 to 20% less than manufacturer's rating. With seven good hours of sunlight we can produce about 2,366 Watt-hours of energy in the summer. In the winter sunlight can be as little as three hours per day, or 1,014 Watt-hours. This amount of panel production is the bare minimum for our level of use. Had we known this, our original system design would have been different.

The distinction made between summer and winter production is central. For one month either side of winter solstice we can expect only three to four hours per day of top production on the sunniest days. Ideally you should size your system using minimum production and maximum use period figures. In other words, if you are using 1,500 Watts-hours over 24 hours but producing only 900, you have a problem. Either you have to boost production or reduce consumption. We must reduce consumption during continuously cloudy winter days.

### Evans' Electrical Energy Consumption

<i>Appliance</i>	<i>Qty</i>	<i>Each Watts</i>	<i>Total Watts</i>	<i>Hrs/Day</i>	<i>W-h/Day</i>	<i>Days/Week</i>	<i>W-h/Week</i>	<i>Average W-h/Day</i>	<i>% Daily Average</i>
Washing Machine	1	1450	1450	1.0	1450	3	4350	621	32.6%
Sun Frost Fridge/Freezer	1	60	60	7.0	420	7	2940	420	22.0%
Water pump	1	373	373	0.5	187	7	1306	187	9.8%
TV	1	60	60	2.0	120	7	840	120	6.3%
Compact Fluorescent Lights	3	13	39	3.0	117	7	819	117	6.1%
Pw Cords	2	13	25	4.0	100	7	700	100	5.2%
Electronic Piano	1	90	90	1.0	90	5	450	64	3.4%
Computer	1	55	55	1.0	55	7	385	55	2.9%
Iron	1	1500	1500	0.3	375	1	375	54	2.8%
Gas Dryer	1	250	250	1.0	250	1	250	36	1.9%
Toaster	1	900	900	0.3	225	1	225	32	1.7%
Hair curler	1	750	750	0.3	188	1	188	27	1.4%
Monitor	1	14	14	1.0	14	7	101	14	0.8%
Blender	1	400	400	0.3	100	1	100	14	0.7%
Printer	1	12	12	1.0	12	7	84	12	0.6%
Battery Charger	1	8	8	10.0	80	1	80	11	0.6%
Stereo	1	30	30	0.5	15	4	60	9	0.4%
VCR	1	19	19	0.5	10	4	38	5	0.3%
CD Player	1	10	10	0.5	5	4	20	3	0.1%
Radio	1	10	10	0.5	5	4	20	3	0.1%
Vacuum cleaner	1	78	78	0.1	4	2	8	1	0.1%
<i>Totals</i>					3821		13338	1905	

## Systems

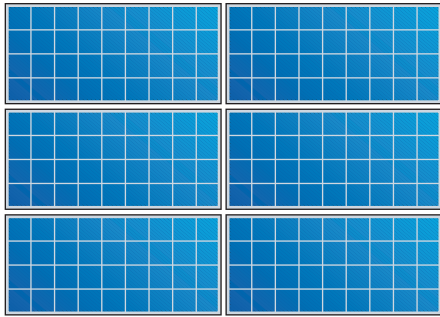

Eight Photovoltaic Panels  
Kyocera 51 Watt, wired for 12 Volt

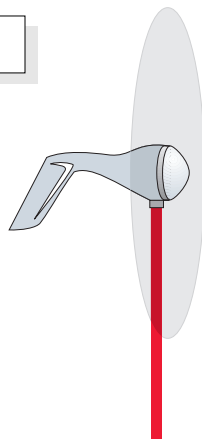

Wind Generator  
Southwest Windpower  
Air 303, 300 Watt

### Evans System Costs

Quan	Material	Cost
8	Kyocera 51 Watt PVs w/Frame	\$3,000
1	Trace 2512 Mod. SW Inverter	\$2,500
	Generac 4000 Generator, Diehard 60 Amp Charger, 5 Yrs. Gasoline	\$1,500
	Control Box, Poles, Gauges, Misc.	\$1,200
1	Air 303 Wind Genny	\$1,000
10	Trojan T-105 6 Volt L-A Batteries	\$800
<b>Total</b>		<b>\$10,000</b>

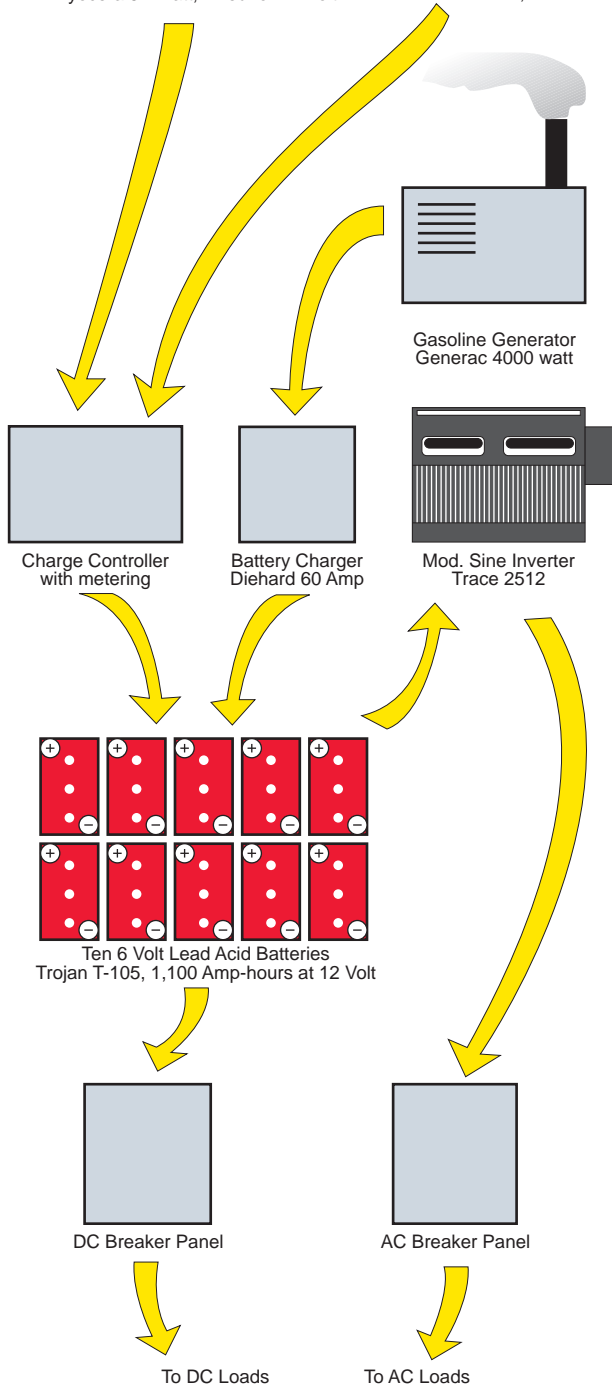

Once we began living with our system we started to learn more about how it functioned, how to evaluate performance, our use patterns, and how to troubleshoot. It is an ever evolving process.

The Air 303 wind generator will produce anywhere from 2 to 30+ Amps depending on wind conditions. It has a voltage range of 13.8 to 17.8. The internal regulator is set at around 15 to 15.5 Volts. This means that the charge will automatically shut off at this level. Theoretically you can equalize with this kind of capacity. It translates to 150 Watts at 10 Amps production in 15 to 20 mph of wind speed and 300 Watts at 25 to 30 mph to as high as 450 Watts in extreme wind conditions. Wind is intermittent, yet it does have the advantage of production at night and during storms on a year round basis. The wind can blow hard during the entire night and give a nice boost to the system. It complements photovoltaic output.

We get more out of our system by using energy as it is produced than we do by pulling it out of storage. Loss through inefficiency is reduced by arranging activities and uses for the strong sunlight periods. We try to strike a balance by keeping a surplus charge in the batteries. In that way we are not deeply cycling the batteries and are gaining maximum energy available before it is lost to battery inefficiency. This is evidenced by the fact that the batteries can show that they are topped off, that is at maximum voltage when the sun is out and charging the system, and immediately drop off in voltage when the sun goes down in the evening. Simply, you can siphon off excess water at the top of the bucket before it evaporates or spills over the side. How far down the voltage drops is also a measure of battery health. Even in the best of conditions there is tremendous drop off when charging ceases at the end of the day. Patterns of use become an important feature when managing your system.

Each of our batteries is rated at 220 Ampere-hours, which means we have an 1,100 Amp hour rating. This is divided by half because 50% of capacity must be



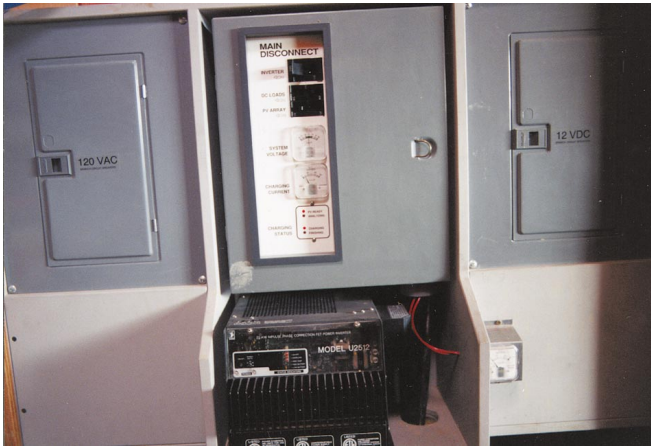

Above: Inverter, instrumentation, and breakers.

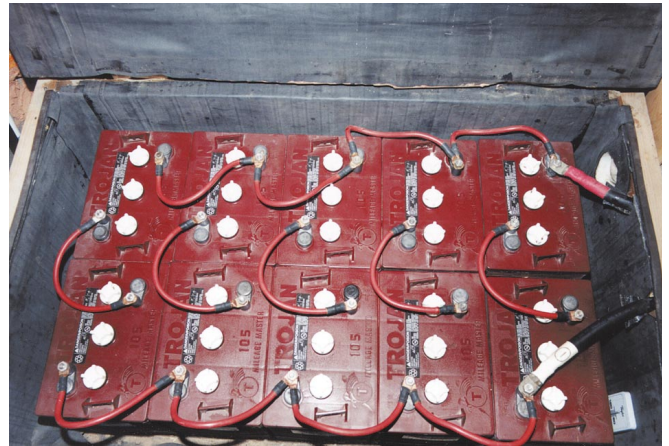

Above: Battery—1100 Ampere-hours at 12 VDC.

routinely kept in storage to prevent the batteries from discharging too deeply and aging prematurely. We then have 550 Ampere-hours available for routine use. This times 12 Volts nets 6,600 Watt-hours of usable energy stored in our battery. Theoretically then, in a fully charged state we have just about three days of available energy stored, assuming our current level of use. Actual available energy is probably less due to loss of battery efficiency over time. The batteries have been in continuous operation for over two years since they were in use during the construction phase, and are beginning to show some signs of degradation. Overall specific gravity levels are within adequate performance levels.

Batteries must be monitored and equalized regularly, more so during the winter months and depending on use. During our first year and a half (including construction) we did not do an equalizing charge. We did not understand the need for this and assumed that our panels would equalize during sunny days. This proved to be less than adequate as the panels are regulated to stop production when the batteries are charged at around 14.4 Volts. (This is a regulation setting that I do not yet know how to override). Thus by design, the system does not provide proper equalization. To tune up our batteries requires holding the level of input at or around 15 Volts for an extended period of time, approximately three to five hours. This tends to bring all the cells in line with each other and results in the batteries holding more charge over a longer period of time.

A larger capacity battery would offer a longer and stronger supply of energy. Our initial battery selection was based on cost and the general attitude that the golf cart style battery is a good beginner battery. We do know that our batteries have cycled deeply too often and were not equalized often enough. There is a risk

buying the best batteries when you do not have sufficient knowledge of systems, operations, and maintenance to prevent potential damage. Golf cart batteries will take some punishment and save money while you learn, but won't hold as much energy as larger ones. Within the next two to five years, we will step up to a larger battery bank.

In our first year we installed the eight solar panels with no generator for backup. In March 1996, we added the AIR 303 because during the winter months we had less energy that we wanted. Our first winter had many cloudy days and we had no way of compensating for the lack of sunshine for an extended period of time. The wind generator allowed us to expand use by producing during those cloudy periods as strong winds often precede stormy weather.

We were using a 1950 model Servel propane refrigerator. In July 1996, we upgraded to a Sun Frost RF 12. Our energy production through the summer months was adequate. By fall and into the winter our overall production was not enough to meet demand. Adding the Sun Frost tipped the balance in our system toward more demand than supply. We purchased the Generac 4000, gasoline-powered, engine/generator in early 1997 to alleviate this problem.

Our generator is used for equalization and supplemental charging during extended cloudy periods. It will produce anywhere from 20 Amps when the batteries are full to 45 to 60 Amps when the batteries are deeply discharged. It has some equivalent production characteristics to the wind generator. But, it produces continuously, whereas the wind generator is intermittent.

The Sun Frost, while being one of the most efficient units in the world, is rated at 4 Amps. The unit cycles and runs about 30% of the time netting seven hours



Above: The Earthship's roof is used to collect water.

each day. Run time is also dependent on fridge temperature settings and room temperature. This translates to 336 to 420 Watt-hours each day. You should size your system according to the worst case projections, noting how you use energy and calculating the least number of hours of production.

Our water pump required special attention also. The architect of our "Earthship" planned for a DC pump but it burned up in the first five minutes of operation. Our water supply is in an underground cistern, about 20 feet from the filtration area inside the house and must be drawn up five to ten feet to the filtration and pressurization systems. We purchased the minimum size pump for this application, a 1/2 HP centrifugal surface AC unit, rated for continuous use. 1 HP equals 745 watts, so divided by two equals 373 watts. The unit runs three to five minutes at a time with a surge of 1500 to 3000 watts. So a ballpark estimate of use is the best we have come up with. With a surge guess in mind we may use 75 to 100 Watt-hours on each run of the pump. What we know for sure is that the voltage meter drops at least a half Volt with each running. It does recover with about 15 minutes passing. Recovery is greater on the low end of the scale as opposed to the higher voltage range. In other words the drop off rate is faster at higher voltage than at lower. This is due to battery resistance and electrical current flow. The supply at the top of the bucket being more easily drawn off. We are still researching pumps that use less energy and are more efficient, but have yet to make another choice.

Another factor to be considered is the washing machine. We bought a mainstream apartment size unit. Rated draw is a significant 1450 watts. This probably fluctuates with the cycle, with total running time per load at about 18 to 20 minutes. We do four loads per week on average, or about 273.4 Watt-hours daily not counting a surge factor. Surge on the washing machine must be in the 3000 to 4000 watt range based on observations of the system in operation and assuming a 6000 watt surge rating on the Trace inverter. We have seen the inverter kick off with the simultaneous start of the washer and the water pump. They will run together when started alternately, but over-surge the inverter when started at the same moment.

When you add the gas dryer into the equation it becomes more interesting. The washer, dryer, and water pump will run together. If the washer and water pump are running together and the dryer switches on, the surge does not exceed inverter limitations and all will operate. If, however, the washer and dryer are running, the surge of the water pump will exceed the limits and shut down the inverter. Once again, we continue to research efficient equipment alternatives.

It is difficult to quantify the actual energy use in surges. We know it is a factor of consumption and it is usually ignored in sizing information and product advertising. Energy consumption is clearly an area that must be quantified at some level. Load charts are the quickest way to accomplish that. Often the promotional literature will not have the amperage or voltage information, let alone surge ratings and other needed information. So we've learned to call a sales person at the dealership or even the manufacturer directly.



Above: An inside view of the Evans' home.

Very important to understanding and designing a system are patterns of use. For instance, we have found that when doing wash you should do it not only when there is strong sunshine available, but after your system has charged itself. (I mention sun only because it is much more predictable than wind.) In other words, we found that depleting your system just because you have the ability to replace the energy is less efficient.

Roof design was a factor affecting our energy system. Our array was originally installed above the roof line at the back of our house. We hand built two kiva style fireplaces in the house which had backdraft problems. When we put up additional stacks to achieve better draws, the chimney cast a shadow on the array during winter afternoons. A shadow, we learned the hard way, doesn't just slow the panel down, it shuts off the circuitry in the panel. This tends to seriously limit production! We ended up moving the array.

Battery placement is another factor. In addition to ventilation concerns, the batteries need to be easily accessible. Suffice it to say, it can be very uncomfortable testing specific gravity on your hands and knees in a confined space with no lighting. Code in our area created definite restrictions on placement and venting requiring special attention and cost.

### In Summary

There are three areas of concern in setting up a RE system: energy production, energy storage, and energy consumption. All three must be understood and analyzed separately and then related to each other. A fourth area to be considered is home design for equipment placement. Each component has to be considered for price and for compatibility. Size your system and your needs carefully before you make purchases.

The more you can anticipate your needs and type of system for all circumstances, the better your chances of saving time, labor, and money. A small PV system in tandem with a wind turbine can be used dependably for a wide variety of purposes. The issue central to system size is lifestyle. If you want to match the capacity of an on-grid home then you will need a very large system. If you decide to limit use and curtail energy related activities then you will be able to live with a smaller investment. Our form of conservation depends on the knowledge that peak power consumption and off-hour use can be successfully balanced.

### Access

Authors: Jeff and Linda Brotman-Evans, PO Box 2827, Grand Junction, CO 81502 • 970-256-7405



TRACE ENGINEERING

four color on negatives

7.2 wide

4.5 high

# EXELTECH

INTRODUCES THE NEW...

## MX SERIES INVERTER



See you at the  
Midwest Renewable  
Energy Fair '97

The world's first truly N+1 redundant *true* sine wave power inverter. This means no single malfunction will cause the unit to fail. All systems are modular, expandable, "hot" insertable and remote capable, with power levels up to 20 KW.

- true sine wave
- most reliable inverter
- input voltages from 12Vdc up to 120Vdc

2225 E. Loop 820 N.-Ft. Worth, TX 76118-7101 voice: 817.595.4969 fax: 817.595.1290  
toll free: 800.886.4683 email address: info@exeltech.com

# Solar Energy International

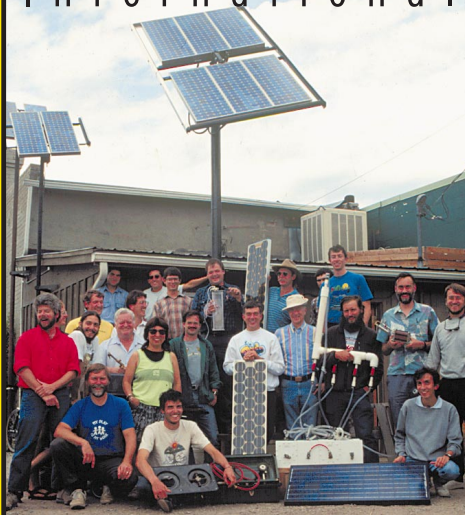

Knows

# Photovoltaics

## For Course Information & Catalog

voice: (970) 963-8855 • fax: (970) 963-8866

e-mail: [sei@solarenergy.org](mailto:sei@solarenergy.org)

web: [www.solarenergy.org](http://www.solarenergy.org)

P.O. Box 715, Carbondale, Colorado, USA 81623

## SOUTHWEST WINDPOWER

camera ready  
four color

7.125 wide  
4.5 high



# TECHNOLOGY

## SOLAR-ONE™ TECHNOLOGY AT WORK: THE HIGH UTILIZATION POSITIVE PLATE

Innovative technology is what separates Solar-One™ from the rest of the pack. Delivering full capacity for more total cycles than conventional batteries, Solar-One batteries are engineered for outstanding performance, from the inside out!

**A** Take a close look at the Solar-One unique high-utilization positive plate, and you will see that it is our positive grid that provides the foundation for Solar-One Positive Plate Technology. Incorporating the highest quality raw material available in the industry. The Solar-One grid uses our own metallurgical formulation and a computer-controlled grid casting system, another industry exclusive! The result:

**B** the Solar-One grid contains larger lead crystals, and larger crystals mean fewer points for corrosion to attack the battery.

**C** To accommodate grid corrosion and growth, many battery manufacturers are forced to use a "floating seal", a battery design which is far more subject to leakage than the Solar-One's burned post-to-cover seal. Having controlled the growth of our positive grid, the Solar-One seal is stronger and less vulnerable to leakage.

**D** The key to Solar-One's



tradition of longer battery life at full capacity is our patented H.U.P. technology (US patent #4,135,829.). H.U.P. is a process which optimizes both the active material utilization and the longevity of the positive paste. A colloidal suspension of

tetrafluoroethylene (Teflon®) is added, at precisely measured volume, temperature, and time, to the paste mix and causes the formation of a pervasive network of fibers throughout the active material.

**E** This process known as fibrillation, locks the active material into place and virtually eliminates flaking and shedding - the chief causes of battery failure.

**F** Tested at the National Battery Testing facility batteries with H.U.P. have been shown to increase working life by at least 20%, with absolutely no sacrifice of capacity! In fact, H.U.P. batteries deliver full capacity longer, have faster voltage recovery with lower internal resistance, and last longer than conventional batteries. For more power in your Renewable Energy System look for the H.U.P. Solar-One™ label. High Utilization Positive plate technology only from:



The First Name In R-E Batteries

P.O. BOX 137  
Colburn, ID, 83865  
800-718-8816  
208-263-6142  
Fax 208-265-3677  
<http://www.nwes.com>



Dealer Inquiries Invited.

Free Shipping for the HUP Solar-One in Canada and 48 States. Ten Year Factory Warranty.



# 800-718-8816



UNI-SOLAR  
United Solar Systems Corp.  
**SUN FROST**



# Hydrogen Storage



Walt Pyle

©1997 Walt Pyle

Above: LPG tanks used as medium pressure storage for hydrogen and oxygen.

**H**ydrogen storage is needed for homes, businesses, and vehicles, to realize the dream of the Solar Hydrogen Age. Since hydrogen gas is useful as a fuel for cooking, heating, electricity production, and vehicle propulsion, we need a way to store the solar hydrogen made during the day for use at night, and seasonally as well.

For more insight on how this wonderful fuel can be used and produced see HP# 33 and 43 for articles on cooking with hydrogen, HP# 34 for space heating with hydrogen, HP# 35 for making electricity with hydrogen, and HP# 22, 36, 39 for articles on hydrogen production from PV and wind electricity.

Most home energy use occurs in the evening when there is no solar hydrogen production occurring from a home hydrogen plant. Over-night hydrogen storage can solve this problem. Summer-time solar hydrogen production can meet or exceed home consumption requirements. Winter-time hydrogen demand (for heating) is maximum at the time when solar hydrogen production is at a minimum. Seasonal home storage can correct this out-of-phase relationship.

Vehicles require on-board storage of hydrogen fuel, and fuel providers away from home (service stations) require larger bulk hydrogen storage capacity. Storage options for hydrogen to be used at home are considered in this article.

## What are some of the storage options for hydrogen?

Many different schemes have been investigated and applied in research programs and demonstrations since the first "oil shock" in 1973. Some of the options are listed below:

- compressed hydrogen gas (CHG) in cylinders or tanks
- tethered balloon, "bag", or water displacement tank (low pressure CHG)
- hydrogen adsorbed into metal to form metal hydride (MH)
- liquid hydrogen (LH<sub>2</sub>) in cryogenic tank
- adsorption on high-surface-area carbon powder in tank
- encapsulation in glass micro-spheres (experimental)
- adsorption on carbon "nano-tubes" (experimental)
- in water (H<sub>2</sub>O) (not a "fuel")

- in ammonia (NH<sub>3</sub>)
- in liquid hydro-carbons: gasoline, diesel fuel, alcohol, liquid natural gas (LNG), propane or butane (LPG), etc.
- in gaseous hydrocarbons: compressed natural gas (CNG), bio-gas, etc.

The first three hydrogen storage options above, CHG, MH, and LH<sub>2</sub>, are the “state-of-the-art” methods most frequently applied in vehicular and stationary applications. The energy density of different hydrogen storage options are shown below, and compared to that of gasoline.

The last two hydrogen storage options, using liquid and gaseous hydro-carbons, are the fossil-fuels that dominate our global fuel production and consumption systems today. For example, a large amount of hydrogen is added to petroleum feedstock to make gasoline. These liquid hydrocarbon fuels are widely used in transportation because of their extremely high energy density.

In this article we are focusing on the CHG and MH storage options, since they are the easiest to implement for home power applications at this time. LH<sub>2</sub> production requires a large energy-expenditure for refrigeration to liquefy gaseous hydrogen. LH<sub>2</sub> is primarily used for transportation applications, so we choose not to elaborate on this method now. We also “gloss over” the experimental hydrogen storage options in this article, since their values are still being proven.

**Safety First!**

If hydrogen is to be stored, it must first be made safe to store. Hydrogen and air, or hydrogen and oxygen

**Solar Hydrogen System**

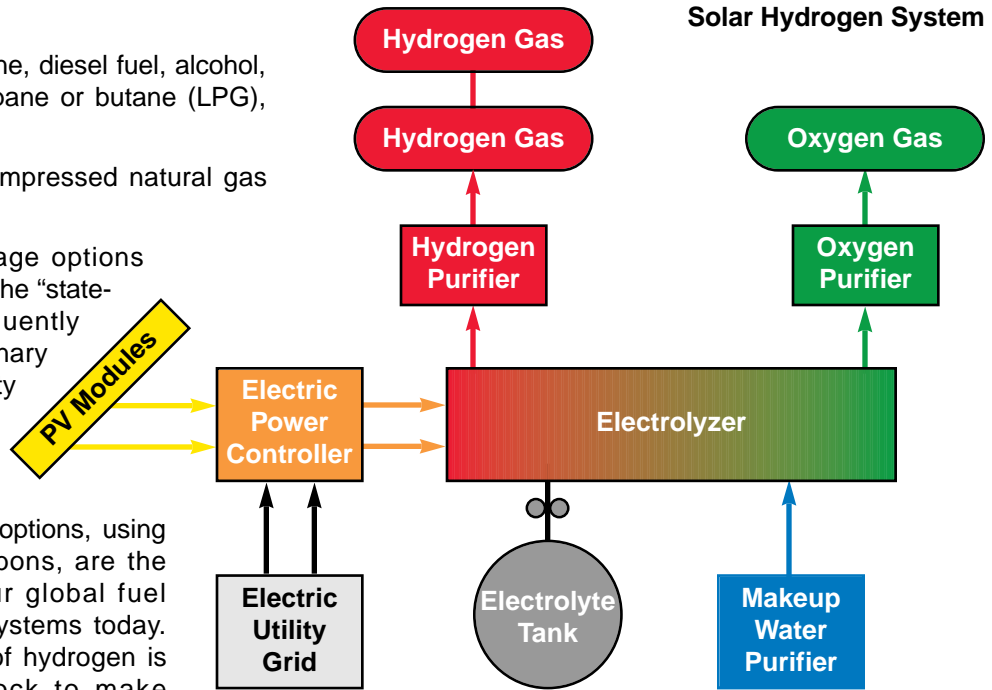

mixtures are not safe to store if the O<sub>2</sub> contamination is significant. Hydrogen has much wider flammable and explosive limits compared to other fuels, especially in hydrogen-rich mixtures with air or oxygen. Hydrogen flammable limits are shown on page 16 and compared to some common fossil fuels.

Hydrogen should never be stored unless it is well below the lower flammable limit (LFL). Normally, industry standards for storage safety call for well below 0.25 LFL, (or less than 1% oxygen in the hydrogen.) To meet this standard, some way of accurately measuring the oxygen contaminant in the produced solar hydrogen must be available. Some hydrogen sensors are listed in the access section at the end of this article

**Gross Energy Densities of Various Fuel Systems**

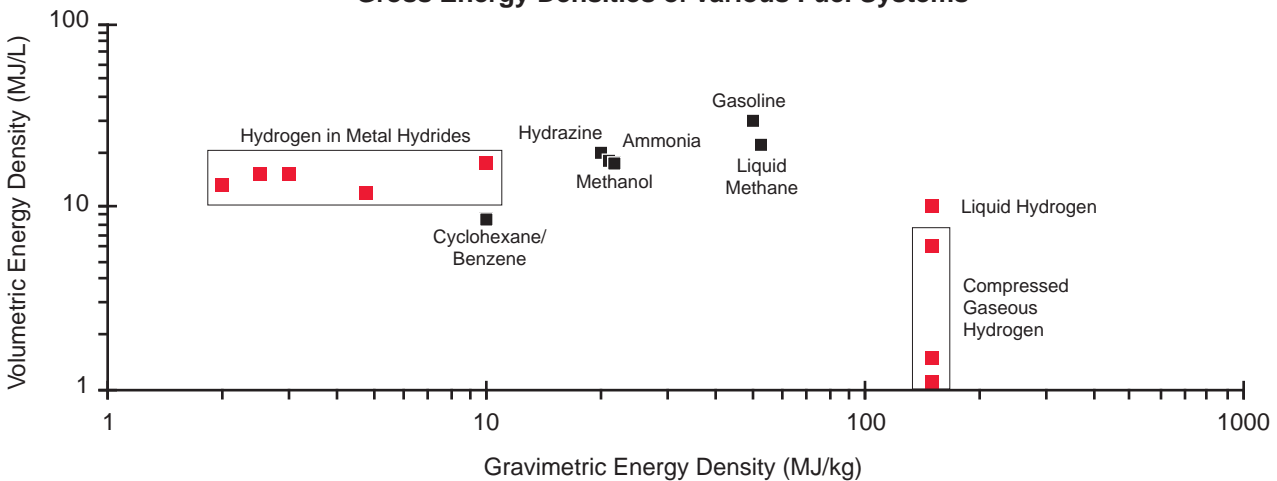

# Hydrogen

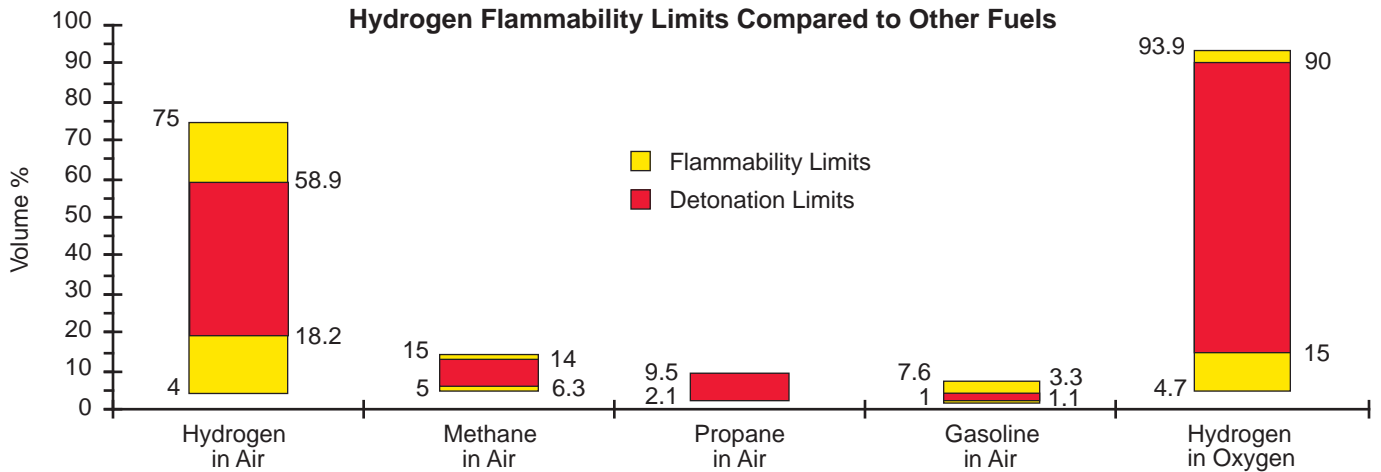

## Compressed Hydrogen Gas (CHG)

CHG is one of the simplest methods for storing hydrogen fuel for later use. The hydrogen storage density becomes greater as the pressure is increased.

Hydrogen production from an electrolyzer can provide pressures suitable for storage at low and medium pressures.

Low-pressure CHG is the basis for balloon or “bag” storage, often seen used for weather balloons or for “bag” storage of fuel gas. The same principle is applied to hydrogen storage that has been used for natural gas storage at low pressure: bus roof storage bags and underground water displacement tanks. Low-pressure tanks are widely used in China and India for storage of bio-gas fuels.

Pressures in these low-pressure CHG containers are only slightly above atmospheric pressure, and they are characterized by very large volume and low container weight.

## Medium Pressure CHG Storage

This type of storage has been done using tanks originally designed for air or propane (LPG) service. Typically these tanks are rated for about 17 bar (250 psig) maximum pressure in the intended service, and de-rated to 4.1 to 8.6 bar (60 to 125 psig) maximum when used for storing hydrogen.

The tank alloy should be low-carbon steel or another material resistant to, or unaffected by, hydrogen embrittlement (weakening) of the tank alloy. High-carbon steel tanks are not appropriate for storing hydrogen under pressure. To avoid hydrogen tank embrittlement, avoid steels that are: a) cold-rolled or cold-forged, or b) have weld hard spots in excess of about Vickers Hardness Number 260.

Non-metal tanks such as composite-fiber tanks avoid hydrogen embrittlement concerns and de-rating.

Medium-pressure CHG storage tanks are characterized as having smaller size and greater weight, for a given storage capacity, relative to low-pressure CHG tanks.

## Safety First!

Tanks intended for use with significant hydrogen pressure should be hydrostatically tested to at least twice the intended operating pressure, and equipped with a suitable pressure release device. All storage tanks for hydrogen should be installed outdoors, never inside buildings or enclosed spaces. A flash-back arrestor should be used on each of the tank’s input and output lines to prevent flame propagation, in the event a flammable mixture forms due to any mistake or system break-down.

## High Pressure CHG Storage

This is the densest compressed hydrogen gas storage option. A compressor is normally used to increase the hydrogen pressure. Typical storage pressures of 140 to 400 bar (2000 to 5800 psig) maximum are used in welding cylinders, tube trailers, and composite-fiber cylinders. It is possible to eliminate the hydrogen compressor by operating the hydrogen production process at the desired high pressure, for example, by using a high-pressure electrolyzer.

Most merchant CHG that is used for welding or other industrial purposes is handled in steel cylinders that contain 5.7 to 8.5 m<sup>3</sup> (200 to 300 scf). These small cylinders are about 1.4 m high and 0.2 m diameter (56 inches high and 8 inches diameter). When we have visited hydrogen demonstration projects we observed lots of these small cylinders in use. Usually, they were all empty! When we recently filled-up one of our small cylinders with 99.95 % welding purity CHG at our local supplier, it cost \$22.50 for the gas, or, about 10 cents per scf. A cylinder of electronic grade high purity hydrogen costs about three times as much.



Tube trailers can supply larger applications. The cylinders in tube trailers are much larger. Tube trailers are available in 10, 36, and 45 tube versions as well as a 10 tube ISO container version.

**Metal Hydride (MH) Storage**

MH is an option for storing hydrogen that is very dense and safe. The down-side is that the hydrogen produced for MH storage must be very high purity. That is, the produced hydrogen must have a very low oxygen contaminant content. Typically 10 ppm O<sub>2</sub> maximum in H<sub>2</sub> must be achieved, so as not to damage the MH storage alloy. Carbon monoxide, hydro-carbon, and water contaminants must also be very low. Contaminants can alter the MH surface so that hydrogen will not be adsorbed. MH storage containers are relatively heavy compared to LH<sub>2</sub>, but MH container weight is of greater concern for transportation application than it is for home storage.

The MH alloys are characterized in several “families” according to the ratio of the alloying elements: AB, A2B, AB2, AB5, etc.. We chose to work with an AB2 alloy, called Hydralloy C made by GFE in Germany. Hydralloy C has A = titanium and zirconium, and B = vanadium, iron, nickel, chromium, and manganese. The main elemental ingredients of Hydralloy C are iron and titanium. Hydralloy C holds about 2% hydrogen by weight when fully charged, and about 1.5% is recoverable during normal charge-discharge cycling.

The hydrogen is stored in these MH alloys after they are “activated” using a break-in treatment process on newly produced alloy. The activation procedure is only used once normally, and extremes of temperature, vacuum, and hydrogen pressure are needed for the procedure. Activation removes the oxide surface films

**Metal Hydride Storage**

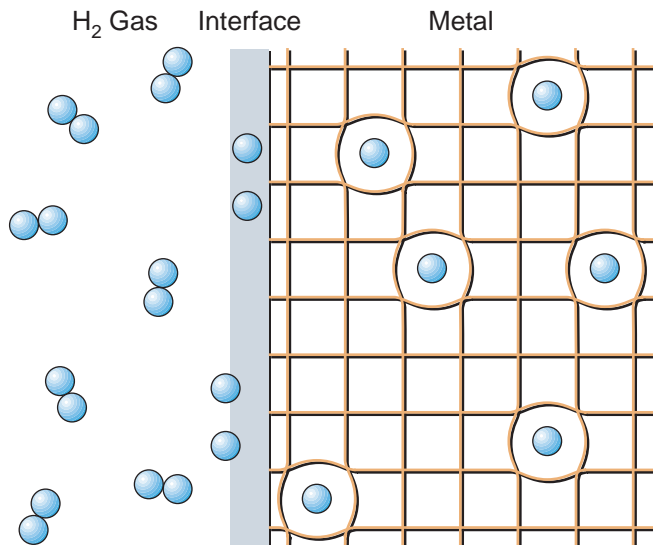

from the alloy, giving the hydrogen molecules access to the metal alloy surface.

When hydrogen molecules (H<sub>2</sub>) arrive at a clean MH surface they dissociate to produce two hydrogen atoms (2 H). The hydrogen atoms are so small they enter the crystal structure of the metal alloy and fill the voids between the metal atoms. The pressure and weight % for charge/discharge reactions are shown below. The curves shown are for one temperature; the pressure curves will increase for higher temperatures and decrease for lower temperatures.

**Charging & Discharging Metal Hydride Cylinder**

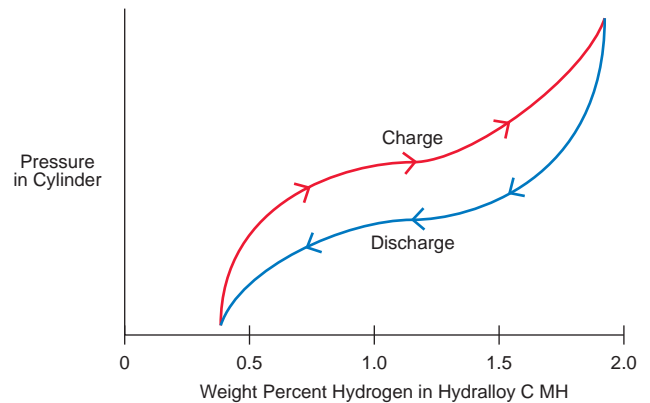

**Hydrogen Storage Homebrew**

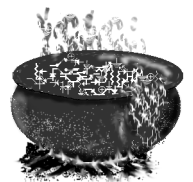

Activation of a tank filled with MH was accomplished after a few false-starts. Our first attempt was made using a small high-pressure cylinder (originally intended for CO<sub>2</sub> storage for life-boat inflation) that we obtained at an industrial surplus store. The cylinder had a volume of 2.3 liters (0.035 scf), weighed 3.6 kg (8 lbs) and carried a DOT rating of 3AA 145 bar (2100 psig). A rupture-disk rated at 139 bar (2000 psig) is installed in the brass cap.

The copper washer used to seal the cylinder cap was wet-polished with fine emery paper and then coated on both sides with a thin film of Permatex Ultra Copper Hi-Temp RTV Silicone Gasket P/N 101B, just before re-assembly. We loaded the cylinder with 6.8 kg (15 lbs) of Hydralloy C, about two-thirds full, to conservatively allow for more than 18% expansion of the alloy, expected after activation.

The cylinder components (cap, particle filter, isolation valve, thermocouple, pressure relief valve, rupture-disk, and pressure gauge) worked fine, but our first activation procedure did not work. In the figure below the cylinder

## Hydrogen



Left: CO<sub>2</sub> cylinder to be converted to H<sub>2</sub> storage in metal hydride.

Below:  
Filling cylinder with alloy.

is shown with a pressure relief valve, filter, shut-off and isolation valve, a supply line for hydrogen, and a vacuum line to evacuate the cylinder during "rinsing" steps.

The first MH activation attempt involved heating the cylinder by wrapping electrical heating tape around the cylinder as shown in the next figure. The highest temperature achievable without melting the heating tape insulation was 182 deg. C (360 deg. F) during the "rinse" steps with medium pressure hydrogen filling followed by vacuum pumping. The pressure applied was 13 to 34.5 bar (190 to 500 psig) during the last step of the procedure. No activation occurred. We believe this was because we did not have the cylinder hot enough



during the rinse cycles, or did not apply adequate pressure during the last step (we were limited to 500 psig max. by our relief valve at that juncture.)

Our next attempt was made using a higher temperature electric tube-furnace obtained at our favorite industrial junk-yard. The heater was cleaned, then wired to ac power, with each of three zone-heaters connected to a variac for temperature control. The temperature of the MH container was measured with a thermocouple, and pressure was monitored with a pressure transducer. Hydrogen flow was measured and controlled during activation using a mass-flowmeter. All of the data was collected on a PC data acquisition system.

We successfully used this MH activation recipe for Hydralloy C:

- 1 Evacuate container of MH to 10<sup>-2</sup> mbar (about 10 mTorr) using mechanical vacuum pump.
- 2 Turn off vacuum and charge MH container with 5 bar (72.5 psig) pure hydrogen (99.999% or better) at room temperature.

Below Left: Filter, valves, & fittings on MH cylinder.

Below: Heating tape did not work!

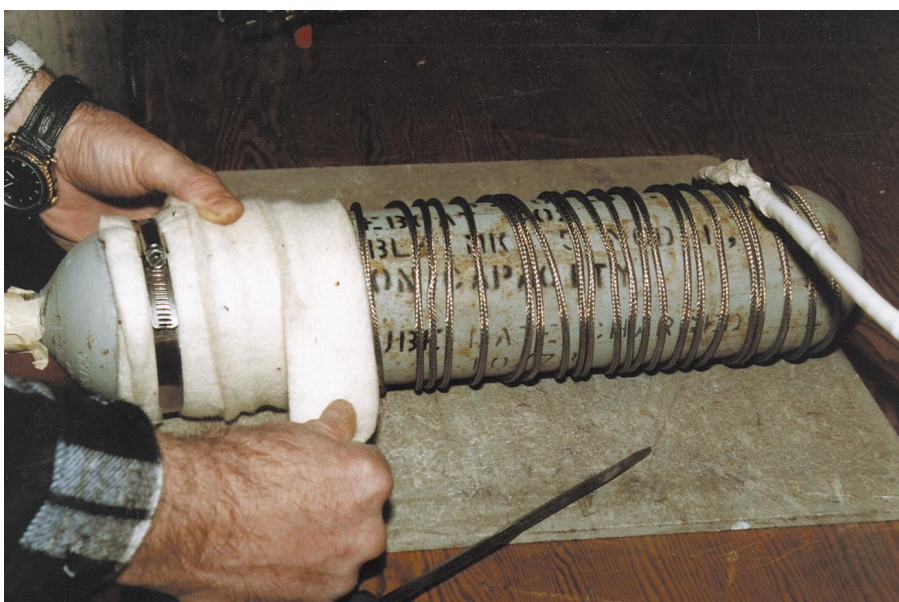
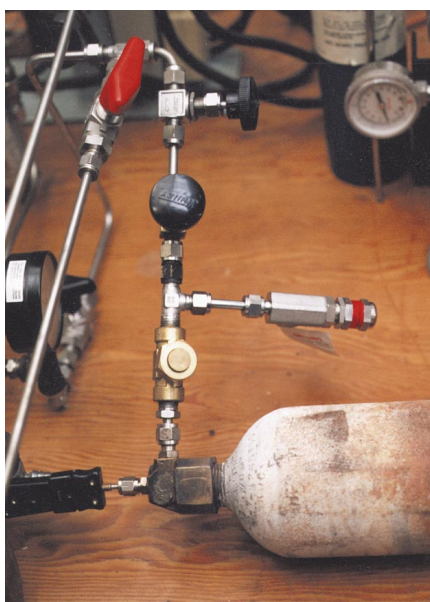



Above: Luigi Bonadio preparing tube furnace.



Above: Electric tube furnace ready for activation of MH cylinders.

- 3 Make a leak test with gas leak detector, if system is tight and there are no leaks, proceed.
- 4 Turn off hydrogen supply and vacuum out MH container to complete first "rinse" cycle.
- 5 Repeat hydrogen charge to 5 bar.
- 6 Remove H<sub>2</sub> by vacuum pump to 10<sup>-2</sup> mbar to complete the second "rinse."
- 7 Heat container in tube-furnace to 375 deg.C (707 deg.F) while continuing to evacuate to remove hydrogen and contaminants like water vapor (about 4 hours).
- 8 Turn off vacuum and charge MH container with 5 bar pure hydrogen at 375 deg.C (hold for 8 hours).
- 9 Evacuate to complete third "rinse."
- 10 Repeat 5 bar hydrogen charge at 375 C (hold about 4 hours).
- 11 Evacuate to complete fourth "rinse."
- 12 Under 5 bar hydrogen pressure cool down the MH container to room temperature.
- 13 Leak test the cylinder to verify that the sealant is still good after the high temperature rinse steps. If no leaks are present, continue.
- 14 Charge the MH container to between 10 and 20 bar

(150 to 300 psig) with pure hydrogen, to hydride the Hydralloy C. Once hydriding begins the cylinder will heat up and faint "cracking" sounds can be heard coming from the cylinder as the new chunks of Hydralloy C inside crack and break into smaller pieces under the stresses of hydrogen penetration.

- 15 After hydriding is complete and the cylinder cools to room temperature, close hydrogen supply valve and close cylinder's isolation valve, then remove cylinder for use.

During activation under 10 to 20 bar pressure the cylinder becomes very hot due to the heat-of-formation of the metal hydride phase ( $2M + H_2 = 2MH + \text{heat}$ ). Our cylinder container reached a temperature of over 70 deg.C, so we turned on an air fan to cool it. After about two hours the hydriding reaction was complete and the container gradually cooled down to room temperature. Each time the cylinder is filled with hydrogen, the cylinder releases heat. After activation, the cylinder can be re-charged at much lower pressure. For Hydralloy C we were able to recharge the container, after activation, with hydrogen at only 8 bar (100 psig) pressure, without any external heating, cooling, or vacuuming. Using a higher hydrogen pressure during charging resulted in a faster fill and greater heat-release rate. Note; one batch of MH that we made required 50 bar (725 psig) pressure to hydride the first time, probably because of thicker surface oxide films.

# Hydrogen

## Metal Hydride Activation Process

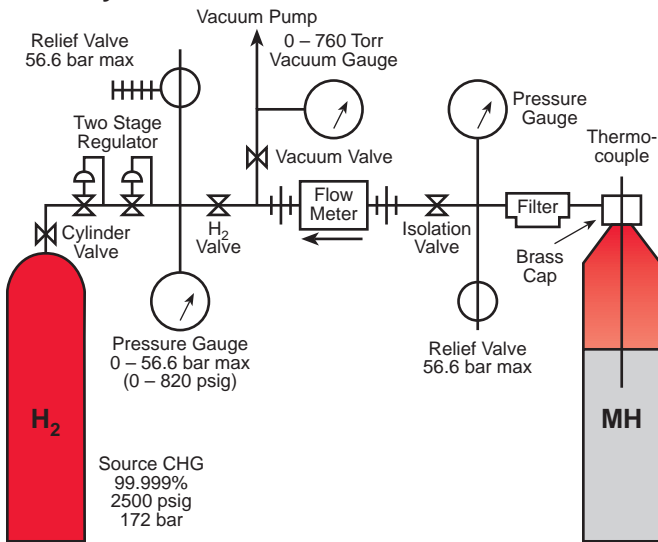

## Removal of Hydrogen from Hydralloy C

This was done by opening the MH container's valve and feeding gas to a hydrogen cooking burner. As the gas was removed from the MH container, the container became cold enough to form ice on the outer surface (from the moisture in the room air freezing). At lower hydrogen removal rates, ice did not form because the container gained heat from the ambient air fast enough to keep up with the reverse reaction ( $2MH + \text{heat} = 2M + H_2$ ). MH has been used in refrigeration systems because of this unique property and because of hydrogen's "ozone friendly" nature compared to other refrigerants like CFCs. A discussion of MH refrigeration is beyond the scope of this article.

Our cylinder container held about 6.8 kg of Hydralloy C so we expected to obtain about 1.5% weight of hydrogen, or about 100 grams of hydrogen on discharge. This might not seem like very much hydrogen, but since hydrogen is very light, the volume of 100 grams hydrogen at atmospheric pressure is large, about 1.1 m<sup>3</sup> (39 scf). Not bad for a cylinder with a volume of 0.0023 m<sup>3</sup> (0.035 scf). By comparison, we would need to boost the pressure in the same cylinder with CHG to  $1.1/0.0023 = 478$  bar to get as much hydrogen into it as with 14 bar in a MH cylinder! Since the cylinder is rated at only 145 bar, this is impossible.

On the first hydrogen fill, the storage volume may not be as large as that obtained after several charge/discharge cycles. The MH breaks down into smaller and smaller particles during the first few cycles and the storage volume increases. We obtained about 0.64 m<sup>3</sup> (640 liters or 23 scf) of hydrogen from the cylinder after the first filling following activation.

The pressure inside a filled Hydralloy C MH cylinder varies from about 5.5 to 8.3 bar (80 to 120 psig) depending on ambient temperature 5 to 27 deg. C (40 to 80 deg. F). When the isolation valve is opened to feed gas to a cooking burner, the pressure drops. If the valve is then closed, after a time the pressure will recover, as the hydrogen leaves the alloy and fills the space in the cylinder. When the cylinder is emptied (weight % H<sub>2</sub> less than about 0.5) the pressure will not recover after valve shutoff, and it is time to recharge the cylinder with hydrogen.

## Future Direction

As we go to press, a second MH container is being activated with Hydralloy C, a third cylinder of Hydralloy F 50/9 (AB 4.8 alloy) is being activated, and a cluster of small MH cylinders is being installed inside a large stainless steel container (formerly used as a swimming pool filter case). Water and anti-freeze solution will be circulated around the MH cylinders, to remove heat during hydrogen charging, and to supply heat during hydrogen discharging. A base support has been added so the pool-filter-case with its MH cylinders can be installed at home or in a small pick-up truck. We'll tell you about it later on.

## Acknowledgments:

Mike Williams, Shieldalloy Metallurgical Corporation for many enlightening discussions on MH and Hydralloy C

Luigi Bonadio, University of Melbourne (Australia) for assistance in activation of Hydralloy C and preparation of experimental hardware and computer data acquisition system at H-Ion Solar Company

Michael Gottschall, GFE Mbh for MH engineering applications information

Dr. Meinhard Aits GFE Mbh for MH technical information

Dale McIntyre, Metallurgical Engineer, Aramco, Saudi Arabia for information about metallurgy of hydrogen handling systems in refineries, sour gas fields, and gas sweetening units

Jim Healy WH6LZ for assembly of laboratory apparatus, experimental data collection, and safety checks

David Booth for assistance with the CO<sub>2</sub> cylinder conversions

Reynaldo Cortez for some of the photographs

## Access:

Author: Walt Pyle WA6DUR, H-Ion Solar Company, 6095 Monterey Avenue Richmond, CA 94805  
Tel: (510) 237-7877 FAX: (510) 232-5251  
e-mail: Hionsolar@aol.com

Metal Hydride Review article: "Hydrogen Metal Systems", by Gary Sandrock, Y. Yurum, Editor, NATO ASI Series E: Applied Sciences - Vol.295, Kluwer Academic Publishers, Dordrecht, 1995, pp.135-166

**Hydralloy C MH-alloy and tank sources**

GFE Mbh, Hofener Strasse 45 D-90431 Nurnberg, Germany Tel: 49 (country code) 93(city code) 15-332 FAX: 49-31-49-80 or 49-9315-491

Shieldalloy Metallurgical Corp., 12 West Boulevard Newfield, New Jersey 08344 Tel: (609) 692-4200 FAX: (609) 692-4017

**Hydrogen Purifiers**

Resource Systems Inc., East Hanover, New Jersey Tel: (201) 884-0650 FAX: (201) 515-3166 RCP-10-2000-4ss catalytic hydrogen purifier

Johnson-Matthey Corp., Orchard Rd, Hertfordshire, SG8 5HE, England Tel: (01763) 25-3000 FAX: (01763) 25-3313 Thin Pd-Ag membrane H<sub>2</sub> purifiers

Bend Research Inc. 64550 Research Road, Bend, Oregon, 97701-8599 Tel: (503) 382 4100 FAX: (503) 382 2713 Pd membrane purifiers

REB Research, Ferndale, Michigan Tel: (810) 545-0155 FAX: (810) 545-5430 Hydrogen purifiers and Membrane Reactors

GPT Inc., Manalapan, New Jersey Tel: (908) 446-2400 FAX: (908) 446-2402 Hydrogen De-oxo purifier D-50-1000

**Hydrogen and Oxygen Purity Sensors**

DCH Technology Inc., Sherman Oaks, California Tel:1-(818) 385-0849 FAX: (818) 385-0849 e-mail: dchinc@aol.com Robust Hydrogen Sensor (ppm to 100% hydrogen)

Figaro USA Inc., Wilmette, Illinois Tel: 1-(708) 256-3546 FAX: (708) 256-3884 KE50 oxygen sensor (to detect oxygen contamination in hydrogen)

Panametrics inc., Waltham, Massachusetts Tel: (800) 8333-9438 FAX: (617)-894-8582 Thermoparamagnetic Oxygen Transmitter 0-5% O<sub>2</sub>

**Hydrogen flash-back arrestors**

Western Enterprises, West Lake, Ohio Model FA3-CV flash-back arrestor with integral check valve (used for acetylene) Tel: (216) 871-2160

Hydrogen pressure relief valves, shut-off valves, tubing, gas filters: Oakland Valve and Fitting Co., Concord, California Tel: (510) 676-4100 Includes Swagelock, Whitey, Cajon, Nupro product lines

**Hydrostatic Testing of Cylinders**

Compressed Gas Association, 1725 Jefferson Davis Highway, Suite 1004, Arlington, Virginia 22202-4102

**Articles on storage of hydrogen in carbon "nano-tubes" and on carbon powder**

"Advanced Materials for Hydrogen Storage: Carbon Nanotubules", T.A. Bekkedahl and M.J. Heben, National Renewable Energy Laboratory, Golden, Colorado

"Hydrogen Storage Systems using Activated Carbon", J.S. Noh, R.K. Agarwal, J.A. Schwarz, Int.J.Hydrogen Energy, Vol.12, No.10, pp.693-700, 1987



**Dealer, Installer**  
 "You benefit from our experience"

**We Evaluate Your Needs  
 You Get Our Personal Service**  
 We Give you expert turnkey installation  
 Sales and Service for Solar, Wind and Hydro.

**Solar Village Institute inc.**  
 910 376-9530  
 PO Box 14  
 Saxapahaw, NC 27340

MORNINGSTAR

four color on film

3.5 wide  
 4.5 high

## Q: How Many Batteries Do You Need to Exceed 800 AH?

**A: Two** for 12 volts, four for 24 Volts, etc.... The point is two 6-CS-25PS's can take the place of 8-10 golf cart batteries while yielding five times the life (10 yr. warranty) and four times the liquid reserve (less topping-up). A drastic decrease in connections eliminates many points of potential failure not to mention just 6 cells to maintain instead of 24 to 30.

Packaged in a Dual-Container Cases that increases strength, durability, and mobility (each cell is removable with a 1/2" wrench). The outer cover insures that the top of your battery will always be clean and dry and eliminates the possibility of a short caused by falling metal objects. The outer container protects you and the environment from potential acid leaks while adding protection to your investment (even with a broken outer case the battery is still fully operable).



6-CS-25PS, 820 AH @ 20hr. rate  
22" (L) x 11 1/4" (W) x 18 1/4" (H)

**Rolls**

**BATTERY ENGINEERING**

**1-800-681-9914**

Dealer inquiries, Surrrette Battery Co. Ltd.  
1 Station Rd., Springhill, NS B0M 1X0

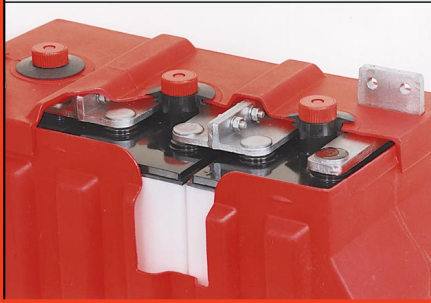

Our 6-CS-25PS is designed with a 0.260" thick enveloped plate that is unmatched by anything on the market. For over 35 years Rolls has been considered the best deep-cycle battery in North America, find out why!

Cutaway of 6-CS-25PS illustrates our Dual-Container Case & Inter-Cell Connections.



**PUMP WATER DIRECTLY FROM THE SUN WITH YOUR AC PUMP!  
-ANY VOLTAGE - IN ANY COUNTRY-**

**INTRODUCING THE**

# **AeroVironment® USPC-2000**

## **UNIVERSAL SOLAR PUMP CONTROLLER**

The **AeroVironment® USPC** is a versatile, high-performance microprocessor controlled, variable speed motor controller for solar powered pumping operations using standard off-the-shelf pumps with 3 phase or 3 wire single phase AC motors - **NO MORE WAITING FOR YOUR SOLAR PUMP!** The USPC 2000 will operate **ANY** AC pump motors from 1/2 HP to 2 HP at any standard voltage - 115, 208, or 230 VAC, 50 or 60 HERTZ. USPC 5000 also available for up to 5 HP AC motors.

### **STANDARD FEATURES**

- ◆ Fault Detection & LED Display
- ◆ System Protection
  - Dry Well
  - Output Overload
  - Over Voltage
  - Over Temperature
- ◆ Selectable Min. & Max. Speeds
- ◆ Peak Power Tracking
- ◆ Two Years Warranty
- ◆ Internal Safety Isolation Switch
- ◆ Power Conversion Efficiency of 97%
- ◆ Will Operate with **ANY** PV Technology Including Crystalline & Thin Film
- ◆ RS 232 Port

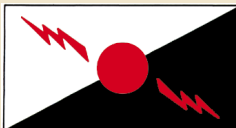

AVAILABLE FROM  
**SOUTHWEST PV SYSTEMS, INC.**  
212 E. MAIN ST. • TOMBALL, TX 77375  
(281) 351-0031 • FAX (281) 351-8356  
E-Mail: [swpv@aol.com](mailto:swpv@aol.com)

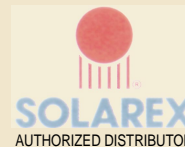

As the #1 Solarex authorized distributor in North America, we also stock a large inventory of PV modules and balance of systems components  
**DEALER INQUIRIES WELCOMED**

LYNCON INDUSTRIES

four color  
on negatives  
3.5 wide  
4.5 high

STATPOWER

four color on negatives  
3.5 wide  
9.175 high

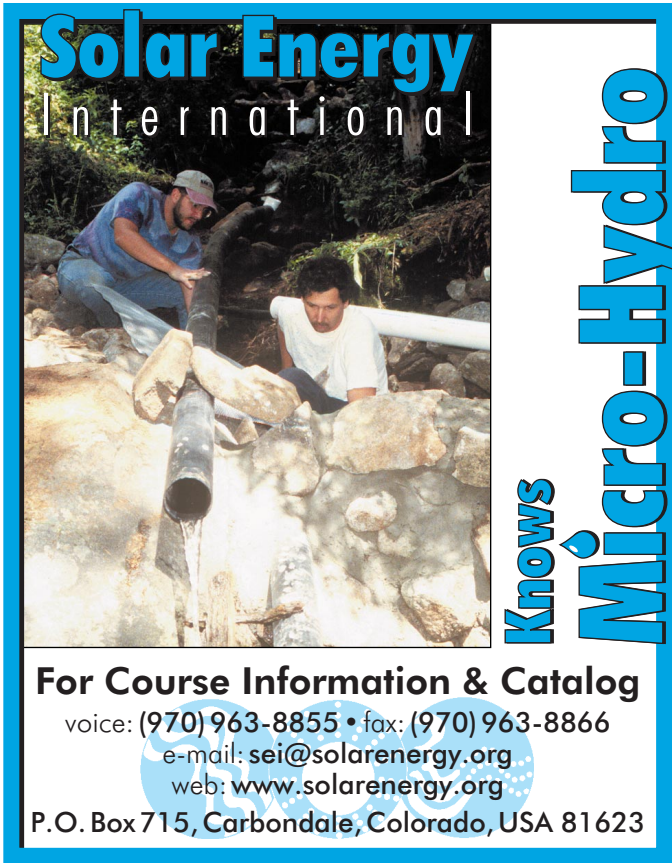

**Solar Energy**  
International

Knows  
**Micro-Hydro**

**For Course Information & Catalog**  
voice: (970) 963-8855 • fax: (970) 963-8866  
e-mail: [sei@solarenergy.org](mailto:sei@solarenergy.org)  
web: [www.solarenergy.org](http://www.solarenergy.org)  
P.O. Box 715, Carbondale, Colorado, USA 81623

# Net Metering On Line

## in Nevada County, California



Above: From left to right, Dennis Trinidad (PG&E District Manager), Jon Hill (system owner), Clay Schmidt (PG&E account representative), and Dan Felix (electrician).

Photo by *The Union*, John Hart

**O**n November 15, 1996, we applied to become the first home PV system in Nevada County, California to become connected to Pacific Gas and Electric (PG&E) under California's recently passed net metering law. From everything we had read in *Home Power* and elsewhere, we were ready for a long, hard battle with the huge utility.

We contacted Clay Schmidt and Mike Bryant from our local PG&E office in Auburn and informed them that we were ready to sign up for net metering. In a few days, the two PG&E representatives came to our home and inspected our system. At that time we supplied them with the documentation requested regarding our Trace SW4024 sine wave inverter. Fortunately, these inverters had already been tested and approved in May 1994, by PG&E for use with their power distribution system.

Several months passed and we had not heard back from them. I found out that they really did not know how to proceed as their office had never processed a net metering application. Mr. Schmidt honestly admitted

that they didn't even know which forms to use. After a few more weeks he called us back and said that they were ready to proceed.

On January 23, Clay Schmidt came back to our house with David Lee and Leo Starns, PG&E substation specialists, to inspect the system once again. David and Lee usually deal with transmission voltages in excess of 60,000 volts, so needless to say, they found our system to be interesting. They found that it lacked only a visible, lockable disconnect to comply with the utility's fairly strict requirements. Within a few days, the appropriate disconnect was installed. On February 4, Clay Schmidt returned and gave final approval to our system. Immediately, we threw the switch and were treated to a rare and truly beautiful sight: a utility meter spinning backwards!

Schmidt admitted it may take a while for PG&E to get used to buying, rather than selling, electricity. "It's bizarre for us because we usually prosecute people whose meter runs backward," he said with a laugh. But it was a pleasant surprise how helpful and cooperative the PG&E employees were throughout the process.

### The System

Our system is not large by today's standards. The heart is a Trace Power Panel with a single SW4024 inverter. The power panel includes a Trace C-40 charge



controller which is generally not required in a line tie system. The only scenario where the C-40 would serve a useful function would be if the power grid was down and we were producing a surplus, with full batteries. As most power outages in our area occur during the winter months this is somewhat unlikely.

A line-tie system does not really need a battery (assuming the appropriate inverter is used), but a high priority for us was to be able to have power for our home in the event of a utility outage. We installed two sets of Pacific Chloride 6-85-21 industrial forklift batteries with a total capacity of 1055 Amp-hours at a 20 hour rate. At our average daily energy usage of about 5 kwh/day, this battery bank would get us by for about four days with an 80% depth of discharge. Draining batteries this deeply is not recommended, but we don't expect this to happen on a regular basis.

Our PV array consists of 16 ten year old ARCO Solar 16-2000 modules, rated at 35 Watts each. This array provides about half of our power requirements during the summer. As it is our goal to produce all of our power in most situations, we will be adding to our array in the next few months. We will soon be installing twelve BP-275 75 Watt single crystal modules mounted on a Zomeworks TRPM12 passive tracker. This additional 900 Watts of PV should provide more power than we need for most of the year.

**Net Metering—How it works**

Whenever we are producing extra power over and above our momentary needs, this surplus power is sold to the utility at the retail rate. During the evening we buy the power back at the same rate. According to state law, as long as we don't show a surplus in any month, we are paid the same rate as we are charged. If we have a surplus for the month we are only paid for the surplus at the wholesale avoided rate, which is a small fraction of the retail rate.

One of the wonderful things about net metering is that we get to use the grid as a battery. Not just any battery, mind you. Because of California's net metering law we can now use the power grid as a battery that will not wear out, unlike a normal battery which has a very finite life. In fact, the battery is the only part of a PV system which needs to be replaced on a regular basis. Also, using the grid as our battery saves a great amount of wear and tear on our lead-acid

**Jon Hill's Intertie System**

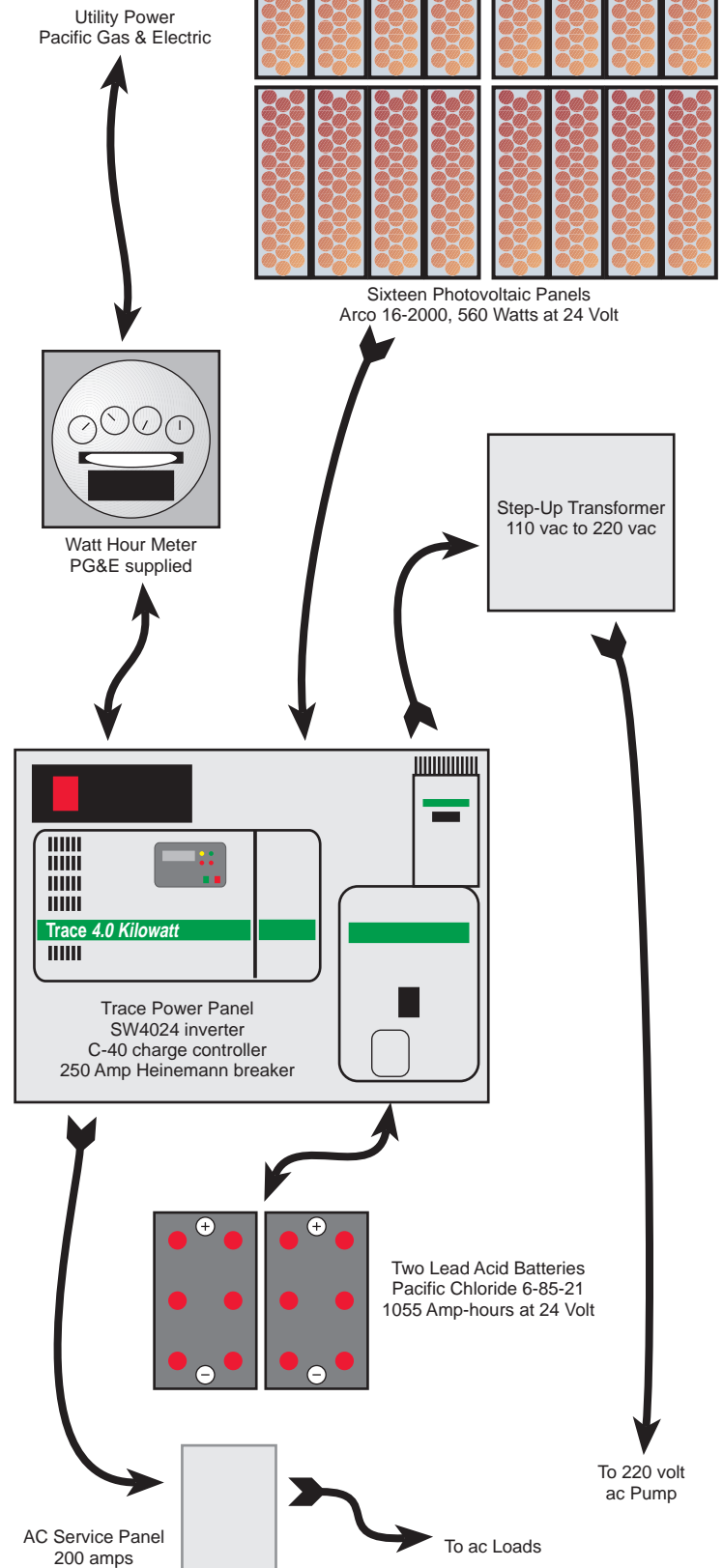

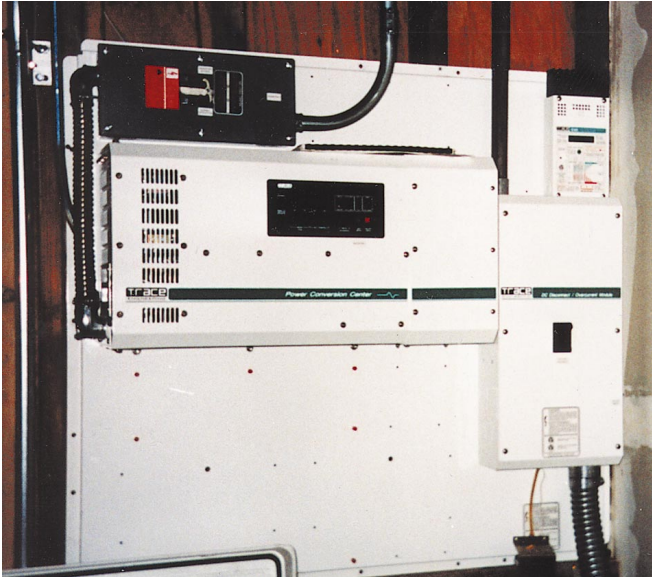

Above: Trace PP-22SW4024 Power Panel with SW4024 inverter, C-40 charge controller, DC-250 Heinemann circuit breaker, and 60 amp bypass breaker set.

Photo by Bob Cobler

batteries, since they will be kept full for 99% of their life. This should give us approximately twice the life on these very costly (and very heavy!) components.

**The House**

Our house is a 1750 square foot passive solar home at 3000 feet elevation in the Sierra Nevada foothills, just outside of Nevada City. It has three bedrooms, two baths, an office, a two car garage, a screened porch, and a 900 square foot deck. All lighting is compact fluorescent and we have a Sun frost RF-16 refrigerator, which we love. Everything else is pretty normal, washer, gas dryer, dishwasher, and a one horsepower



Above: Energy storage: Two Pacific Chloride 6-85-21 lead-acid batteries supplying 1055 Ampere-hours at 24 Volts DC.

Photo by Bob Cobler

**Jon's PV/Utility Intertie System Cost**

#	Component	Cost	%
12	BP Solar 75 Watt PVs	\$4,800	28%
1	Trace SW4024 Power Panel	\$4,667	27%
2	Pacific Chloride Batteries	\$3,600	21%
16	ARCO 16-200 PV Modules	\$2,400	14%
1	Zomeworks 12 PV Tracker	\$1,455	8%
1	4KVA 120/240 Transformer	\$395	2%
<i>Total</i>		<b>\$17,317</b>	

submersible pump in our 500 foot well. The backup to our passive solar heating is a hydronic loop below the first floor, with gas direct vent room heaters upstairs (which almost never get used). Largely due to the compact fluorescents and the Sun Frost our power use is quite modest. Before the PV we were averaging utility bills in the \$16 to \$20 range.

**What's the Big Idea?**

The big idea is to demonstrate that it is entirely possible to live comfortably without using any more of the earth's scarce resources than absolutely necessary. After our PV system is completed in early summer we'll continue to make refinements in how we make and use energy. One important consideration in building our new home has been to test new ideas in energy production and conservation.

Our water is still heated with propane, a fact that I'm almost embarrassed to admit. This will change soon. There are several really effective passive solar hot water systems available.

**Conclusions**

Net metering is not for everyone. But then, neither is solar or energy conservation in general. They all take an extra amount of involvement and extra investment in the short run. To use any of these one must live in a more conscious fashion than the average human being. They all require that we take an active part in how we use and produce power. If we'd prefer to let someone else, i.e. the power company, make these energy decisions for us, so be it. Rather than feeling powerless, some of us would rather take responsibility for where our power comes from and how it is used. It's just a part of reclaiming our personal power from the powers that be.

**Access**

Author: Jonathan Hill, Sierra Solar Systems, 109 Argall Way, Nevada City, CA 95959 • 916-265-8441  
 Fax: 916-265-6151 • E-Mail: solarjon@netshel.net  
 Web: www.sierrasolar.com



Charge batteries faster & with much less fuel

# GennyDeeCee

- 12/24 Volt DC Generator.
- 6.5 HP OHV Honda gasoline engine.
- 100+ amps max output.
- At 75 amps consumes just 0.3 gal/hr. That's 3.2 hours on a gallon of gas!
- Cast Iron Pulley w/ industrial 'A' belt drive.
- Control box has ammeter, maintenance meter (measures RPM, total run time, job time, service alarm), fuse, field timer, and output control.
- Easily capable of charging and equalizing a 2000 A-Hr. battery.
- Charging rates do not "fall off" as your battery fills.
- Quality built in the USA



Introductory Price  
**\$1,285**



For More Info:



4291 Nelson St.  
Taylorsville, CA 95983

**916-284-7849**

GennyDeeCee

## Solar Water Pumps

Economical water supply beyond the power lines



HP author Windy Dankoff installing a SunRise™ Pump

### SunRise™ Submersible Pump for Deep Wells:

4 GPM at 150 ft  
2 GPM at 350 ft  
1 GPM at 600 ft

Non-submersible pumps for surface water sources:

### Solar Slowpump™

.5 to 4 GPM, 450 ft max. lift

### Solar Force™ Piston Pump

3.5 to 9 GPM, 230 ft

### Solar Centrifugal™

10 to 50 GPM

### Flowlight® Booster Pump

Pressurizing to 65 PSI

Manufacturing since 1983. Exclusive U.S.A. Importer & International Sales Representative for SunRise™ by Fluxinos.

### Dankoff Solar Products, Inc.

1807 Second Street, Unit #55  
Santa Fe, NM 87505 • USA  
(505) 820-6611 • Fax (505) 820-3160  
E-mail: pumps@danksolar.com



## TROJAN BATTERY CO.

camera ready  
four color

7.2 wide  
4.5 high

*"The EXELTECH inverter is wonderful...  
I bought it on the strong recommendation of friends and  
thought I was being kind of extravagant at the time. Now  
that I see how it handles my loads and how much happier  
they seem to be on sine wave power I know it was a good  
move."*

*-Don Kulha*

*Former NASA subcontractor  
and Solor power aficionado*



**EXELTECH**

**See you at the  
Midwest Renewable  
Energy Fair '97**

2225 E. Loop 820 N.-Ft. Worth, TX 76118-7101 voice: 817.595.4969 fax: 817.595.1290  
toll free: 800.886.4683 email address: info@exeltech.com

SUNWISE

four color  
on negatives

3.5 wide  
4.52 high

World Power Technologies

camera ready on film  
four color

7.125 wide  
4.5 high

**June 20-22**

**Yeeee-Haaaaw!**  
**It's a comin'**

**1997**  
**Midwest**  
**Renewable**  
**Energy**  
**Fair**  
**Amherst WI**

**"Renewing the City"**

**More than 90 Workshops including...**

Solar Electricity  
Sustainable Cities  
Green Pricing  
Solar Cooking  
Energy Efficiency  
Sustainable Living  
Energy & the Environment  
Batteries & Inverters  
Wind Generators  
Passive Solar Home Design  
Alternative Fuels  
Children's Workshops  
Teacher Curriculum  
Keep Cool W/O Air Conditioning  
Permaculture  
Bicycle Commuting  
Strawbale Construction  
Window Quilts  
Solar & Electric Cars  
Living Renewably in the City

**Hands-On Pre-Fair Workshops**

Install the Systems to Power the Fair...  
Home Sized PV Systems  
Grid Intertie Wind Systems  
Off Grid Wind Systems

**Over 80 Display Booths**

Demonstrating, Displaying, & Selling Innovative Energy Products for use in Home, Business, & Transportation

**Special Exhibits**

Alternative Vehicle Showcase  
Model Home  
Eco-Village Demonstrations

**Keynote Speaker**

Friday, June 20, 6:00 PM: Carl Rábago, Environmental Defense Fund, "Green Power"

Saturday, June 21, 1:30 PM, Mary Tucker, San Jose Environmental Services Dept., "Urban Villages & the Environment"

**Entertainment**

Friday, June 20, 8:00 PM: Open Mic W/ "Living Room Band" small fee  
Saturday, June 21, 7:00 PM: L.J. Booth, 8:30 PM Patty Larkin, \$8.00

**Special Events**

Bus & Bicycle Tours of Alternative Energy Homes  
Silent Auction  
Pancake Breakfast Fundraiser  
Ragin' Rooster Bicycle Race & Tour

**Admission**

Adult: \$7.00 Day, \$15.00 All 3 Days  
Junior (13-17) & Senior: \$3.00 day, \$6.00 All 3 days  
Children: Free!

For More Information Contact:

**Midwest Renewable Energy Association**

**P.O. Box 249, Amherst, WI 54406 • (715) 824-5166**

# Mexican Rural Electrification

Dean Still & Kim Schramm

©1997 Dean Still / Kim Schramm



**O**ne fine warm morning in January '96, two dusty government trucks rolled into San Nicolas, a small Mexican fishing village in the desert of Baja California. Only sixty people live in San Nicolas. It is about fifty miles from the closest town. There's no grid generated electricity available, water is lifted up in buckets from hand-dug wells, and night lighting is mostly from candles or even from burning rags stuck in bottles filled with a mixture of gasoline and water. (Works, but it's smokey.)

The village, a date palm oasis, supports itself through fishing and ranching. The road that brought this visit from the government is only three years old. Before then the fishermen had to make roads through the arroyo which washed out in heavy rains. Now the fish buyers have it easy and after filling trucks with ice and fish can easily drive to the paved road that winds 700 miles up towards San Diego.

## Federales Arrive

I was finishing my first cup of wonderful ranch coffee, freshly roasted from green beans, when the most alert member of our group informed us that the trucks were full of photovoltaic panels, batteries, and wire! We were especially interested in these contents since all of us were either staff or interns from the Aprovecho Research Center, near Cottage Grove, Oregon. Aprovecho had, over the years, helped to bring down and install PV systems in the mayor's house, the little grocery store, medical clinic, etc. We knew how useful lighting can be in the desert, where snakes, scorpions and the like do their moving around in the dark. Nice to at least identify what it was that bit you.

By the time I arrived, coffee in hand, two complete systems had been installed. Amazingly, by the end of the day, ten houses in San Nicolas had functioning PV lighting. Almost everyone there that day had bought a system at the cost of only eighty dollars (U.S.) for the whole enchilada! It turned out that homeowners were to pay 10% of the total wholesale cost (over time). The government was picking up the remaining 90%. What a deal! Wouldn't it be great if a similar program existed in the States?

# with *(Almost Free)* PVs



Below: Home owner Jorge Murillo (right) and crew from *Solidaridad* in San Nicolas.



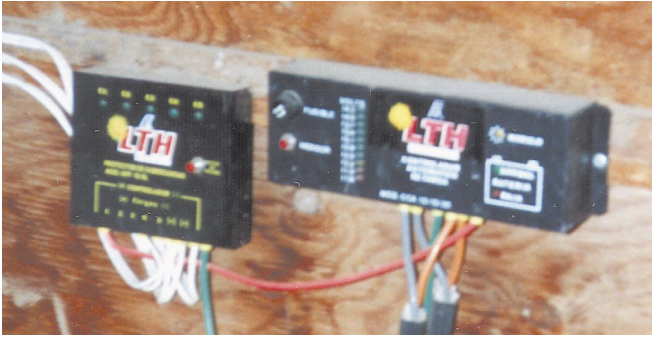

Above: Locally made Mexican charge controls.

The panel was a 58 Watt Solarex installed on top of a ten foot steel pole set in cement. 10-3 wire passed through a charge controller and a meter showing the state of charge of the battery and connected to a 120 Amp hour gel cell deep cycle battery. All of the equipment except the panel was Mexican made. The system included four fluorescent lights with switches that were installed wherever the householder desired. The decision had to be made quickly, however, since the installers were working at lightning speed, staple guns flashing in the sunlight.

The battery was placed inside a sealed and ventilated wooden box. The owner was warned that opening the box would void the year long guarantee. I think that the system designer didn't want these batteries ending up starting cars, etc.

The PVs in San Nicolas were part of a program run by SOLIDARIDAD, the Mexican development department. As of that day 126 systems had been installed in houses far from grid power. All of these houses were in very rural locations in the county of Loreto. For us

Below: The battery in a box.



gringos, this gift had a sudden dreamlike quality. It was almost too good to be true. The village was electrified in one day. That night the gentle glow of fluorescent lights made each house an island in a sea of darkness. San Nicolas became a lot more like a little town.

The PV systems that Aprovecho had installed worked pretty well. The big problem was usually either broken lights or dysfunctional batteries. Batteries would dry up or be ruined by repeated deep cycling. The systems that needed repair required foreign assistance, i.e. with parts mostly unavailable locally. We had to bring stuff down from the U.S., and since our rancho buddies made an average of seven bucks a day, we usually gave it away free. PVs were in the Santa Claus department: great gear but unavailable and way too expensive for normal working folks.

### Appropriate and Alternative

E.F. Schumacher, who wrote *Small is Beautiful*, used two terms to differentiate between types of preferable technologies: appropriate and alternative. Both types are being introduced into developing countries today. Appropriate technology is defined as being made near





where it's used, inexpensive to produce, repairable, and created from locally available resources. Alternative technology defines devices that are less polluting and that use renewable energy sources. PVs are a good example of alternative technology. A home made fuel efficient wood stove or solar cooker is more in line with definitions of being appropriate.

Mahatma Gandhi might have opposed the introduction of PVs for the same reason he opposed machines that made cotton cloth. The technology was not of his culture and brought with it the values of and dependency on another more technologically advanced culture. There are theorists who believe that truly sustainable development has to be appropriate. Giving something like PVs to a newly discovered world would violate the Prime Directive on Star Trek, for example.

A more inclusive view admits that both kinds of technologies are being introduced and that both result in obvious benefits. The long range hope of many alternative tech types is that the introduction of a new, less polluting technology may help a developing country to skip over a phase of development that has left scars and poisons in the richer nations. May it be so!

### Basking in the Light

Probably the most important questions are: How well does the stuff actually function in the real world? Pragmatically, does it work? Is it a good deal?

In an attempt to answer this the crew from Aprovecho has committed to get a sun tan every January and track the success of the installations in San Nicolas. We visited every house this year, and I've gotta tell you that I was impressed by the result. Every system was working perfectly. All of the houses had electric light. The batteries were mostly fully charged.

Four of the houses had a broken light fixture. One house had two lights left of the original four. But all the batteries were still in the boxes although all of the boxes had been opened. Five of the houses had TV's and radios hooked up to the battery. One householder had powered up an electric pump that brought well water to the sink. Without exception all of the people were enthusiastic about the PVs and thought that they were a great deal. The lights had worked without problems for a year.

Ghandi might not be happy with the increased amount of TV watching going on. Sex and violence are as prevalent on Mexican TV as on our own. Village values are definitely confronted by the fast life shown on the programs written, produced, and enacted by rising stars in Mexico City. Without PV electricity, this influence would be diminished. I've got to admit that I myself don't love that ubiquitous blue flickering light.

### Continued Success?

In my experience, a year without serious problems is a really good track record! Village life is hard on equipment, what with pigs, kids, and twenty-four hour life pushing up against things. I am impressed with the durability of the systems and I expect that next year the lights will probably be shining on. With replacement parts available (lights, fluorescent tubes, batteries, etc.) these systems could supply power to San Nicolas for a long time to come.

There are two questions that intrigue me. And I'm looking forward to following up on the success of the San Nicolas installations in order to shed light on them: Will the government follow up with replacement parts? Will these parts be subsidized or not? My dream is that batteries, lights, etc. might one day be available in the little CONOSUPO government supported grocery store in San Nicolas. With this continuing support the gift of light seems assured.

I do wonder if these folks would scrape together the money to buy replacement parts at a retail rate. If they have to, I'd bet that homemade alternatives will quickly replace stock parts! Homemade alternatives are pretty familiar to ranchers all the world round.

Look for an update in the following years. Or if you'd like to check it out yourself, take a left at kilometer 63, south of the town of Mulege in southern Baja. Drive 16 km on the new dirt road and stop when you reach the shady oasis. If it's January, we'll meet you there. We could discuss sustainable development around the campfire.

### Access

Authors: Dean Still & Kim Schramm, 80574 Hazelton Road, Cottage Grove, OR 97424 • 541-942-8198  
E-Mail: apro@efn.org • Web: www.efn.org/~apro

For information about Aprovecho Research Center and our three month training sessions in Appropriate Technology, Sustainable Forestry, Organic Gardening, and Indigenous Skills, please call or feel free to stop by for a visit.



### Universal Post Mount

Our 4 universal post mount models will replace 20 or more brand-specific single pole photovoltaic mounting racks.

- Extra heavy-duty construction withstands high windloading
- Painted steel structure with aluminum mounting rails
- All stainless mounting hardware
- Easily adjusts to seasonal sun angle
- Dealer inquiries invited

**General Specialties 208-265-5244**

3535 Upper Gold Creek, Sandpoint Idaho, USA 83864

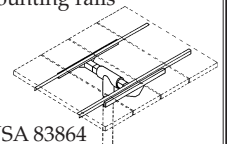

## Tilt Tower Kits for Wind Generators

### Mountain Man Alternative Energy Systems

#### Tilt Tower Kits for:

Southwest Windpower: Air, Windseeker 502, 503  
World Power Technologies: Whisper 600, 900, 1000,  
1500, 3000, & 4500  
Bergey Windpower Co.: BWC 850, 1500, Excel 10kW  
Wind Baron: 750  
*Other turbines upon request*

#### Kits Come Complete:

With tower base, anchors, gin pole bracket, couplers, guy wires, guy wire brackets, hardware, and installation manual. *Lightning rods & pipe sections should be purchased locally.*

#### Hybrid Energy Systems:

Wind, Solar, Diesel, Gas, & Propane Generators  
Batteries, Inverters, & Controls.  
Remember, wind will outperform solar 4 to 10 times at most sites.

#### Very Competitive Pricing:

Concise, easy installation manuals.  
Installation service readily available.

*Call, Fax, or Write for prices, shipping costs, & orders...*

Dennis E. Drescher  
SEI Certified, Wind Solar,  
& Tower Technician  
PO Box 197  
Como, CO 80432  
phone: 719-836-2628  
pager: 719-590-6451

Tim Olsen, PE  
Mechanical Engineer  
1428 S. Homboldt St.  
Denver, CO 80210  
phone: 303-722-1803  
fax: 303-777-7185  
e-mail: [tolsen@aol.com](mailto:tolsen@aol.com)

Communities Magazine

camera ready, b/w

3.5 wide

4.5 high

## BACKWOODS SOLAR ELECTRIC SYSTEMS

**For an Earth Restored and a World at Peace... Independent Electric Power Systems for the  
Remote Home—Solar Electric, Wind, Hydro**

We are a family business, living with our products for over 20 years, and offer the knowledge to help you set up your energy system. Free Consultation. Questions are personally answered.

Our catalog includes a planning guide to help you understand how to put your energy system together - its applications and sizing. We offer lower than usual prices on *Solarex* and *Siemens* PV modules and *Kohler* generators. Our *Trace* inverters include free battery cables. We carry *Sun Frost* and *Nova Kool* refrigerators, specialized appliances and lighting, and a range of meters and controls: *Heliotrope*, *SCI*, *Ananda*, *TriMetric*, and our own *Backwoods* control boxes.

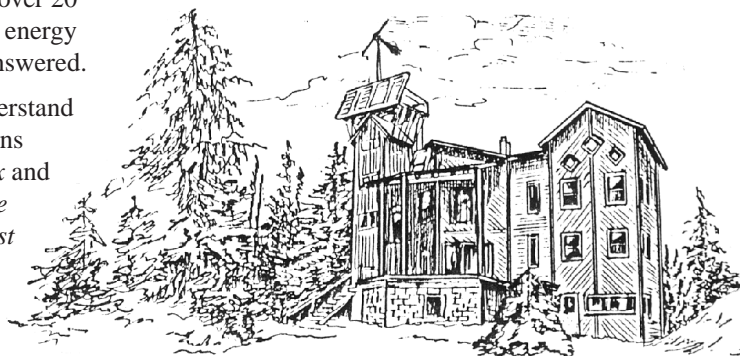

Our \$3. Catalog/planning guide is FREE to *Home Power* readers.

We accept VISA, MasterCard, American Express, and Discover



*Most items in stock for immediate shipment.*

**Steve & Elizabeth Willey • 8530-HP Rapid Lightning Creek Road • Sandpoint, Idaho 83864**

**Telephone: (208) 263-4290 • FAX: (208) 265-4788**

# REXOR SOLAR INDUSTRIES, INC.

PHOTOVOLTAIC MANUFACTURING, DESIGN, ENGINEERING AND APPLICATIONS

**\$531.25**

plus handling & shipping  
@ \$4.25 per watt – UPS shipped

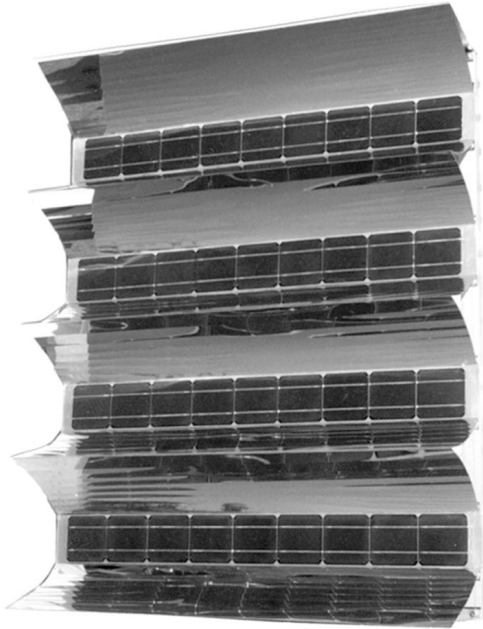

## Reflectorizer 2.5

*High Efficiency Photovoltaic Module*

**Rated Power Output 125 Watt**

**Nominal Power Output 120 to 130 watt**

**Voltage at maximum 19 to 21 volts**

**Current at maximum 6.5 to 7.25 amps**

Module: Winston-Trough Parabolic Photovoltaic Concentrator module

Single Cell: 4" Pseudo Square Single Crystal Silicon Cells.  
Textured Cells with an antireflective coating.

Laminate: Aluminum backsheet, continuous contact design and electrically aligned cell design. Laminated by EVA, UV stability & electrical isolation.

Reflector: This has a low level concentration which does not have to track the sun daily for the seasonal variation. This could be used in a tracking or non-tracking device.

- \* Measured output are at open circuit voltage and short circuit current.
- \* Actual measured outputs are within 5% of the nominal output.
- \* Actual measured outputs will vary depending on the configuration of the angle of incident and the position of the module during the day.
- \* Assembly required.

FOR FURTHER INQUIRY:

**REXOR SOLAR INDUSTRIES, INC.**

1480 SOUTH VINEYARD AVENUE, ONTARIO, CA 91761

**Tel 909-930-1433 / Fax 909-930-1434**

## The TriMetric

*Battery System Monitor*

**Measures VOLTS, AMPS & AMP-HOURS**

**With 7 additional data monitoring functions.**

**Our new Web site has free information  
on battery system  
monitoring**

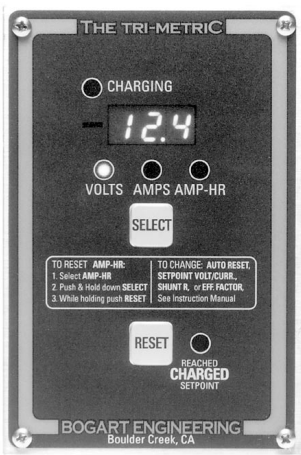

Visit our Web site and get "How to use a TriMetric (or other monitor) to care for your Battery System." (13 pages) It explains "volts," "amps," and "amp-hours" and why they're useful. We're biased, of course, but we believe everyone who depends on batteries should have a battery monitor—even if it's not a TriMetric!) to care for batteries, help conserve energy, and help educate about energy use.

**Dealers:** You're welcome to distribute this to your customers to help them understand their systems better.

The TriMetric sugg. retail is under \$200 with shunt.  
Call your R/E distributor or us for more information  
Web Address: <http://www.bogartengineering.com>

**BOGART ENGINEERING**

19020 Two Bar Road, Boulder Creek, CA 95006 (408) 338-0616

EMI - Environmental Marketing

b/w  
on film

3.51 wide  
4.5 high

# How to Locally Finance Your RE System

Dan and Lori Whitehead

©1997 Dan and Lori Whitehead

The year was 1993 and we had just finished building our log home. We were ready to get started on our wind energy system. The cost of a new wind generator was out of our budget so the plan was to look for a used Jacobs and recondition it. The average price for a reconditioned 17.5 KW Jacobs at that time was 12 to 15 thousand dollars. This is still a lot of money and we did not have it lying around. I did not want to wait 5 years to save up the cash for my wind project.

## The Bad News...

Lending institutions typically have not wanted anything to do with renewable energy projects. This is due to the fact that they know nothing about these systems and they do not know what to do if someone would default on the loan. It is not an easy task to repossess a solar or wind system after it has been installed. Even if they did repossess the system they do not have a blue book for the value of the parts. It is no wonder that banks will not loan money for a renewable energy system.

## What to Do?

Since we didn't have the cash available to start the project, my wife and I decided to put together a presentation for the bank. The first problem is finding a banker who will even listen to you. If at all possible, use a banker who you know and have done business with in the past. This way you have your foot in the door and they will at least listen to your presentation. We planned to show them that they could indeed safely lend money to the average income homeowner for a renewable energy project. The idea was to show the bank that we

were very serious, that we had done all our homework, and that we were experts in the field of renewable energy. We would spend time educating the bank officials in the details of our project and prove that there is a payback and that this is a sound investment.

## Accomplishing this Feat of Magic

First we got approval from the local authorities to install the system. We obtained written approval from the city zoning and building code board. We obtained the contract from our local utility allowing us to interconnect with them and we agreed on a buyback rate. We did a soil check to determine what type of soil that we had to work with. If you find rock at your site, you can expect your foundation costs to double. After we had all of this information ready to present to the bank, we put together a detailed list of the costs. This included the cost of the reconditioned Jacobs, the foundation, wiring, trenching, cement, labor, and other miscellaneous costs. We had these neatly laid out with a total estimated cost at the bottom. Your estimate should be within a couple hundred dollars of the actual cost if you do all of your calculations correctly. The bank wants to know as close as possible what this project is going to cost. If you give them a detailed layout like this, they will be impressed and will assume that you know what you are talking about.

## Wind Energy System Estimated Cost

<i>Material</i>	<i>Cost</i>
17.5 KW Jacobs Wind Generator	\$10,000
120 foot Tower	\$2,000
Backhoe with Operator	\$175
Concrete and Rebar	\$1,578
Angle Iron	\$411
Tower Anchors	\$150
Crane Fee	\$216
Wire and Electrical Parts	\$867
Utility Company Intertie Fee	\$300
Miscellaneous Parts	\$291
<i>Total</i>	<b>\$15,987</b>

We put together detailed charts and graphs of typical production figures for our area using wind assessment charts and production estimates from the manufacturer. Next we showed the estimated annual production figures using the Advanced Aero Technologies blades. These blades will increase annual production by about 30%. We included a typical payback analysis for the system. This analysis showed what the utility will pay for the sold back electricity, what the value of the wind generated electricity is, and what our savings would be.

### Example Projection

#### Average Electrical Use:

1000 kwh x 12 month = 12000 x .10/kwh = \$1200.00/yearly

#### Average kwh Sold to Utility Company: *Subtract monthly use from estimated generation.*

1,620 kwh generated minus 1,000 kwh house used = 610 kwh sold to utility  
 610 kwh sold x 12 mo. = 7,320 kwh / yr x \$0.015 buy back rate = \$109.80 / year

#### Federal Form 8835 Renewable Electrical Production Credit

610 kwh sold x 12 mo. = 7,320 kwh / yr x \$0.015 incentive credit = \$109.80 / year

#### Yearly Savings:

Average Yearly Electrical Use:	\$1,200.00
Average Yearly kwh Sold to Utility Company:	\$109.80
Federal Form 8835 (Yearly)	\$109.80

#### Total Yearly Savings

**\$1,419.60**

There are also depreciation figures (check with your local tax advisor for more information) and a federal production tax incentive (Federal Form 8835) that you can get. Also, check with your own state for any grants or tax incentives for your system as each state offers different incentives. We added in annual estimated maintenance costs, insurance costs, and a final system worth dollar figure at the end of 20 years of operation. To meet our down payment we offered to install the tower base at our cost. This worked out to be about \$3000 out of our pocket. The bank bought into this concept for the down payment. At this point, we fully had their attention and they were asking positive intelligent questions.

I used my experience with installing wind systems as a selling point for my abilities and knowledge. I would do all of the work and ensure that the job was done in a set time frame. If you do not have experience in this field and must rely on someone else to do the installation, simply explain that your installer has the experience needed to do the job. Hopefully this is a true statement or you could be in for a lot of headaches.

#### So Far So Good...

At this point, you should have them eating out of your hands. The only sticky part could be the area of collateral. I was able to convince the bank to use the wind machine itself as collateral. I think that our presentation was so convincing that they believed this was a wise investment and that their money was safe. If

you are unable to convince them to use the machine as collateral you may have to use something else to satisfy their requirements. You might be able to get them to add this loan on to your home mortgage. You can expect that the interest rate for a signature loan will be slightly higher than a conventional loan.

We were fortunate that we were able to convince our bank to lend us the money for our project. I think that it was possible only because we had a very impressive and convincing presentation. We presented ourselves as very knowledgeable and positive. We were able to answer all of their questions and put them at ease by showing that we had done our homework.

You cannot bring too much information with you. Show them everything that you can get your hands on. Show the history of the company you plan to use. Any articles written about positive aspects of your project are also helpful. The more that you can educate them and assure that this is money well spent the better your chances that you will get the loan for your project. Good luck to everyone who tries this approach and please call or send us a message letting us know how it turned out for you.

#### Access

Author: Dan and Lori Whitehead, Illowa Windworks,  
 12197 Nelson Rd., Morrison, IL 61270 • 815-772-4403

See Dan & Lori's wind system: HP #53, page 6



Super Deals On



Power Panel Systems

See the TRACE Engineering ad  
**PRE-WIRED & POWERFUL**  
 Free Truck Freight Delivery to 48 States

**Why Gamble on**  
 ✓ Un-heard-of brands  
 ✓ AbUSED modules  
 ✓ "Economy"  
**lightweights**  
**When you can own**  
**the SIEMENS SM-55?**



**ABRAHAM**  
 Solar Equipment  
 124 Creekside Place  
 Pagosa Springs, CO 81147

**\$299**

Ask About  
 Uni-Solar

LIMITED  
 TIME

**1-800-222-7242**  
 THE POWER BROKERS!™

LIMITED  
 TIME

Staber H-axis washing machine ~~\$1249~~ \$879

Save on shipping! Staber stock in NW USA!

27 Watt Amorphous, new surplus, one \$129

Uni-Solar 64, Scratch-n-Dent, few \$299

No Credit Cards — Saves You 2%

## Extend the Life of Lead-Acid Batteries up to Five Times!

### Tank Tough!

Built for the  
 U.S. Military

10 year limited  
 warranty

8 Ounces of  
 Prevention...

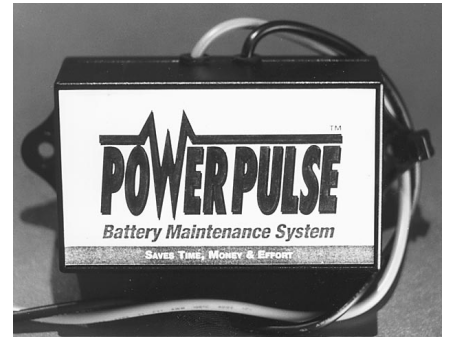

Breaks up hard sulfate crystals...  
 the #1 cause of battery failure.

12 Volt \$69.95 – 24 Volt \$119.95  
 Try one; large packs need more than one.

**Introductory Special!**  
**Free C.O.D. shipping / 48 states**

Higher Voltage Units available—  
 Genuine Re-selling Dealers—

**CALL**

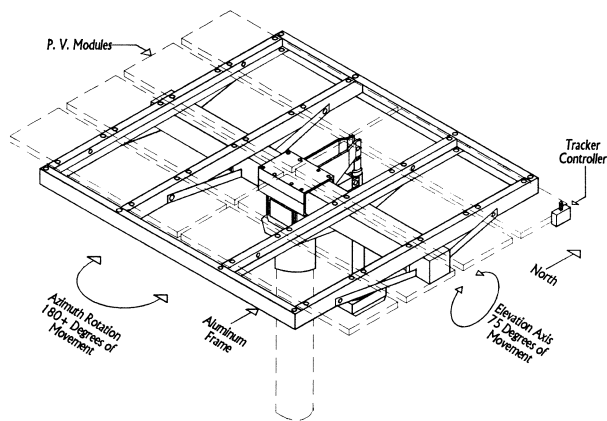

**Delivers up to 40% more power than a fixed mount, for a cost that quickly pays for itself!**

◆ US PATENT #5,317,145 ◆ STRONG ALUMINUM FRAMES

◆ SINGLE OR DUAL AXIS TRACKING ◆ 10 YEAR LIMITED WARRANTY

ARRAY TECHNOLOGIES, INC. 3402 STANFORD NE, ALBUQUERQUE, NM 87107

TEL: (505) 881-7567 FAX: (505) 881-7572

## “HANZI”

Chinese Diesel 10KW Generator Set  
 Water Cooled, Electric Start  
**\$2652 FOB**

- ❖ Turn Key Complete
- ❖ Industrial quality
- ❖ Free tool and overhaul kit
- ❖ 3 full hours on one gallon fuel
- ❖ 230/115 Volts - AC - Single Phase
- ❖ Guaranteed Parts Availability
- ❖ Runs home, small farm, Shop
- ❖ Prompt Shipping
- ❖ One Year Limited Warranty

Call Now to Place Your Order or  
 For More Information

**NEWINLI/CFMC**

3289 Trade Center Dr., Riverside, CA 92507

Tel: 909-683-1090 Fax: 909-683-1091

Tel: 909-657-0379 Fax: 909-657-8120

## AUTOMAGIC BATTERY WATERING



### WE MAKE WATER FROM YOUR GAS

Hydrogen and oxygen battery gas catalytically recombined into pure water and returned to each battery cell. Keeps battery topped off for extended periods of time and reduces maintenance costs. Explosive hydrogen gas is virtually eliminated from the battery area. Corrosive spray and fumes are contained and washed back into each battery cell. Electrolyte kept strong longer, extending the useful power and life of the battery. HYDROCAP Vents simply replace the battery's caps. Battery maintenance is greatly reduced. Write or call for more information.



Things that Work!

**Hydrocap**  
CATALYST BATTERY CAPS®

305-696-2504  
975 NW 95 St.  
Miami, FL 33150

## BP SOLAR

camera ready  
b/w

3.5 wide  
9.0 high

LEAVE THE  
BLACK BORDER  
ON!

# Illowa Windworks

*Authorized Dealer of Jacobs  
& Advanced Aero Technologies*

*Servicing the Illinois / Iowa Region*

**30% Increased Annual Output  
from your Jacobs**

- Advanced Aero Tech. Blades  
Designed to fit Jacobs 10 thru 20 KW
- Virtually Maintenance Free
- Resists Ice Build Up

Sales of New & Used Jacobs  
Service & Preventative Maintenance Available

**Write or Call Now  
For Free Information**

12197 Nelson Rd.  
Morrison, IL 61270  
(815) 772-4403

Dan & Lori  
Whitehead

# Things that Work!



## Morningstar's SunSaver PV Battery Charge Controller

Chuck Kurnik

©1997 Chuck Kurnik

This is a constant voltage, pulse-width modulated (PWM), battery charge controller designed for 12 Volt PV systems using lead-acid batteries.

Other generators, such as a wind generator or micro hydro turbine, can be connected to the battery without disconnecting the controller, but the other source must not be connected directly to the controller. It has built-in temperature compensation of -20 mV/degree C, with a reference of 25 degree C (77 degree F). It is available in the five configurations summarized below.

SunSaver-6	No LVD
SunSaver-6	LVD rated 6 A
SunSaver-6	LVD rated 10 A
SunSaver-10	No LVD
SunSaver-10	LVD rated 10 A

LVD: Low Voltage Disconnect. If battery voltage falls below 11.3 V, the controller shuts down the load. The load will be reconnected after the battery is charged to 12.3 V. Models without LVD are rated to handle a load of 10 A.

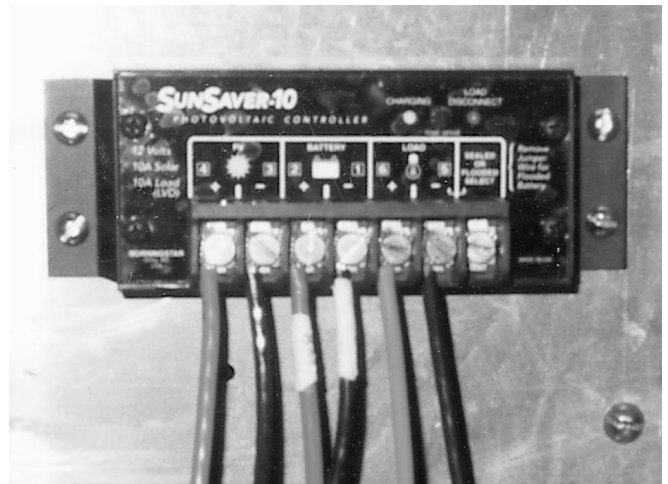

The "6" and "10" in the name refer to PV current. The model under test is the SunSaver-10, with LVD rated at 10 A. Morningstar also makes larger charge controllers, some complete with instrumentation.

### Documentation

The documentation is very good. All the operator needs to do is read the page worth of "Quick Start Instructions" to have the controller up and running. The rest of the manual should be read to give the user an idea of the functions and limitations of the equipment. There are also two pages of detailed troubleshooting documentation.

A confusing aspect of the "Spec Summary" in the manual is that it has a value in the LVD column for all models, even the ones without the LVD option. This makes it appear that all models have LVD.

### Physical Examination

The controller is a petite 6 inches wide x 2-3/16 inches high x 1-3/8 inches deep, weighing 8 ounces. The front panel is clearly labeled, with a green LED to indicate charging and a red LED to indicate that the load has been disconnected by the LVD. The operator can actually wire the controller into the system without even looking at the manual; the battery, PV, and load terminals are labeled in the order that the connections are to be made. The temperature sensing device is also visible and labeled on the front panel.

The device is specified as being weather-resistant, which it appears to be. The case is electrolytically anodized aluminum and is filled with epoxy. The marine-rated terminals are copper-plated brass with nickel-plated brass screws. The back of the case is a heatsink with an air gap to allow for adequate cooling.

A deficiency in the front cover is the way that it is attached to the rest of the unit. The four screws that



hold on the front cover are not actually screwed into holes; they appear to be self-tapped into a gap between the outer housing and the inner, electrical housing. This should not be a problem unless the operator insists on throwing around the controller and prying at the front cover with a screw driver. The front cover is nothing more than a plate to hold the terminal label and LED label; the electronics are covered with epoxy.

**Installation and Test System**

The controller was installed between a 53 peak Watts PV module and a 105 Amp-hour battery at 12 VDC. The controller was easily wall-mounted with four screws. The unit comes with a jumper that is used to select sealed or flooded batteries. The jumper is to be installed on the terminal block if the system uses sealed batteries, but was not needed in this installation because this system uses flooded batteries. It has been in service for about seven months and counting, between 9/96 and 3/97, in Dekalb, IL. The system was outside draped with plastic until it was brought inside in Dec 1996.

**Control Operation**

In any type of system, the ease of use and degree of flexibility are inversely proportional; this controller is no exception. It is very easy to set up, but the only flexibility the operator has is whether to select flooded or sealed batteries. The user must decide whether his/her system requires a flexible charge control. The test system does not require much flexibility.

This PWM controller is noticeably more efficient than the shunt controller previously used in the system. Sandia National Labs has shown that lead-acid batteries really like PWM as a charging algorithm. When the battery is full, the controller floats the voltage at 14.5 volts. The specification is 14.4 volts. Given that the accuracy of the float voltage for flooded batteries is +/-55mV, and the temperature in the battery room is

closer to 70 deg F, this where it should be. The trickle charge current is 0.4 A.

There does not appear to be any over-current protection on the PV or battery side of the controller; the manual says that the device can tolerate 25% over the specs for up to five minutes, but running in this mode "will reduce the safety margins for surges and will cause overheating that can shorten the life of the controller."

The LVD functioned as specified. The controller ran flawlessly at the maximum load current. No heat was detected anywhere it shouldn't be on the device. To test the weather-resistance, the device was splashed with a small bit (only a small bit!) of water. It continued to operate as advertised.

**Cost**

The cost range for this controller is \$55-\$92, depending on the model. This particular model cost \$81. Surface Mount Technology (SMT) keeps down the cost and ensures high quality of the controller. Contact your local PV dealer or Morningstar (see Access below) for a brochure.

**Conclusions**

I can recommend Morningstar's SunSaver controller as "Things that Work!". It is very easy to set up and use, and has great documentation. It is designed for use in PV systems using flooded or sealed lead-acid batteries. If you have a small PV system that does not require flexibility in set points, check out this efficient controller.

**Access**

Author: Chuck Kurnik, 427 S. 6th St., Dekalb, IL 60115

Control Maker: Morningstar Corp., 1098 Washington Crossing Rd., Washington Crossing, PA 18977  
Phone: 215-321-4457 • FAX: 215-321-4458





**BERGEY WIND TURBINES — QUALITY-PERFORMANCE-VALUE**

Bergey wind turbines incorporate the latest technologies in aerodynamics, structures, and electronic controls. They benefit from more than eighteen years of Bergey Windpower R & D and production. They have been delivered to all 50 states and more than 60 countries around the world.

Featuring BWC's patented POWERFLEX® fiberglass blades, Bergey rotor systems provide three-blade smoothness and power. The AUTOFURL™ system protects the turbines in high winds through a unique combination of aerodynamics and gravitational forces—without the need for springs or brakes.

Bergey wind turbines are available in three sizes: 850 watts (shown at left), 1500 watts, and 10 kilowatts. Specifically designed for remote applications, all three incorporate the aerodynamic and design features that have made Bergey wind turbines the standard for quality, performance, and value throughout the world.

Call or write for more information about our world class wind turbines and related energy equipment.

**BERGEY WINDPOWER CO., INC.**  
2001 Priestley Ave., Norman, OK 73069  
Telephone: (405) 364-4212  
Fax: (405) 364-2078

# Harris Hydroelectric

## Hydro-Power for Home Use

Works with heads as low as 10 feet • Price starts at \$750

### New Features:

17 bucket reshaped Pelton wheel

Powder coated castings

More efficient stator in high output models

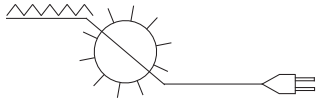

632 Swanton Road  
Davenport, CA 95017  
408-425-7652

*"The best Alternator-based MicroHydro generator I've ever seen."  
Bob-O Schultze, Hydroelectric Editor, Home Power Magazine*

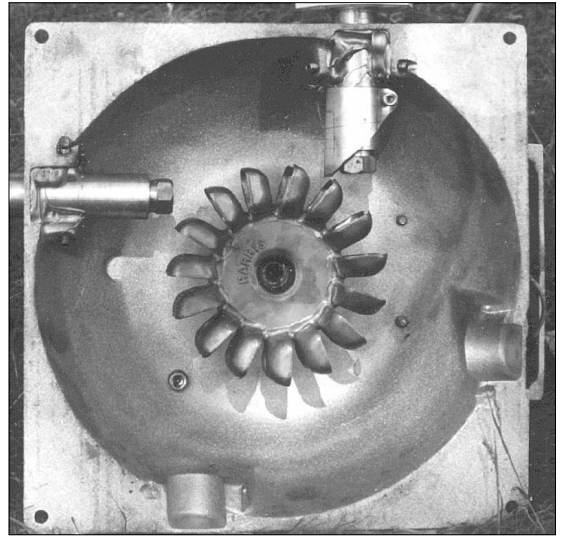

### SNORKEL STOVE CO

camera ready b/w  
3.5 wide  
3.4 high

### NATURAL ENERGY SYSTEMS

camera ready  
b/w  
  
3.5 wide  
3.3 high

### WESTCO BATTERY

camera ready b/w  
7.3 wide  
3.0 high

# SOLAR CHEF®



The Solar Chef will cook or bake any food under the Sun and do it in conventional cooking times. (capable of 500°F)

## THE HEALTHIEST WAY TO COOK—FOR YOU & THE PLANET

FOR MORE INFORMATION CALL OR WRITE



541-471-6065  
800-378-4189



220 SOUTHRIDGE WAY, GRANTS PASS, OR 97527

## NEW ENGLAND SOLAR ELECTRIC, INC.

*Formerly Fowler Solar Electric Inc.*

226 Huntington Road PO Box 435  
Worthington, MA 01098  
1-800-914-4131

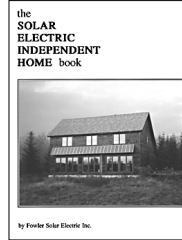

**\$16.95 plus \$2 UPS**  
(includes our \$3 catalog)

This is the most popular book for PV remote homes. It is written and published by Fowler Solar Electric Inc.

“Best all around book on wiring your PV system.”

1991 Real Goods Sourcebook

“Our favorite book for Do-It-Yourselfers.”

Windy Dankoff, Flowlight Solar Power

“This should become the bible for alternative energy users.”

Ken Cox, President Trace Inverters

**Send \$3 for our 64 page catalog and product guide**

Servel/Dometic Gas Refrigerators. Trace Inverters. Trojan Batteries.  
Siemens & Solarex PV modules, Osram Bulbs. Thinlite Fixtures  
Aquastar Hot Water Heaters. AIR 303 Wind Generators

***Best book, most user friendly catalog,  
& best kits in the business.***

## ALTERNATIVE ENERGY ENGINEERING

camera ready

b/w

7.125 wide

4.5 high

# Low Cost Solar House Heating

Chester Johnson & Joel Chinkes

©1997 Chester Johnson & Joel Chinkes



Above: Adobe house in desert setting, with ten house heating panels set into a ditch. Eleventh panel, at right, is for domestic hot water heating.

**A**dmittedly, when it comes to winter, southern New Mexico is not Minnesota. Even so, at elevations above 4,000 feet, winter lows average well below freezing and chilly days are not unheard of.

Chester Johnson, a retired engineer and builder, and his wife Eleanor, decided to take advantage of abundant southwest winter sunshine to heat their house. For under \$1,000 he designed and built a closed loop whole house heating system that has served them well for the past seven years, and is still working just fine.

## The House

Only in New Mexico is it considered elegant to live in a modified mud hut. Chester's 3,000 plus square foot adobe home sits exposed on a wide flat desert, from whose soil it was constructed. Paradoxically, the home is hidden and private. Adobe walls come into view only at close range, since wind blown sand has raised nearby terrain into undulations around the base of each surrounding mesquite bush and tamarisk. A pedestrian cannot see a desert house any further away than a

swimmer can see a ship in a wave-swept ocean, although distant mountain peaks are visible in all directions.

The house sits on a built up layer of sand and gravel. A perimeter trench holds the poured concrete foundation. Twelve inch walls consist of four inch thick adobe brick, four inches of ordinary insulated wood stud wall, then four more inches of adobe brick. This massive wall allows heat swings of only about one degree per day if you turn off the heating or cooling systems.

Inside the foundation perimeter, a thin layer of concrete was poured over a serpentine bed of about one thousand feet of one inch black plastic water pipe. Decorative floor tile was then laid over the concrete pad.

## Panel Design

Chester shunned complications of all sorts in planning his sophisticated home heating system. Less is more. The parts are all very inexpensive standard hardware items, easily assembled in a simple but rugged way.

The main outdoor ingredients are corrugated metal roofing, sliding door tempered glass, and drip irrigation pipes. A few two by fours and a length of rain gutter complete the ensemble. Two sheets of metal roofing

are wedged to the back of a sheet of glass using redwood two by fours, although cedar or perhaps metal house studs would work just as well. The top side of corrugated metal facing the glass is cleaned with vinegar and painted black. Chester used 6000 °F stove paint.

Each panel is just a little larger than whatever size large, cheap tempered glass you can find. Ordinary patio door glass is 46 by 76 inches and costs \$70 or less in quantity. Get replacement glass sheets, because you don't need all the sliding door hardware that comes with a new door. Set the glass into the wooden frame and hold it down with a generous bead of silicone caulk.

Corrugated aluminum roof panels measure 26 by 96 inches and cost \$6 each. You need four metal sheets per glass panel, since the metal sheets are only about half the width of your glass. Overlap the two narrow metal pieces and use silicon caulk and pop rivets to attach left and right halves. Your lumber yard has wavy precut wood available to give good support to the wavy metal roofing. Bend up both sides of the metal panels to reduce water leaks. Caulk all the side joints, but not the top and bottom edges, which must dribble.

The finished panel will have a piece of tempered glass framed on four sides, and supported across the middle if the glass is real thin and droops. The left and right sides of the window frame will support the bent-up edges of painted corrugated roofing. Two sheets of metal roofing will protrude top and bottom beyond the window frame. No worries about steam explosions with this plan, as the whole system is open to the atmosphere.

Chester's panels lean at a winter sun angle against the side wall of a handy south facing trench in the dirt. This keeps the panels out of sight and protected from winds. Similar panels could be roof mounted if you don't have ground space for a large trench. Each panel of approximately four by eight feet generates a measured value of 5,000 BTU. Chester uses ten such panels to warm his large but well insulated home.

### Water Flow

The water system is almost too simple to believe compared to complex factory made water manifolds. A fractional horsepower electric sump pump is placed just above the bottom of a concrete well. In Chester's case, his grid-powered pump is 1/25 horsepower, and cost about \$100. (A solar powered pump is planned.) For the sump he used an enameled clothes washing machine tub and concreted around it, adding a lid. The sump can be located outdoors in front of and below the panels, or indoors in your garage if you worry a lot about freezing. Don't put the pump pickup at the very bottom of the

### Panel Construction: Horizontal Cross-Section

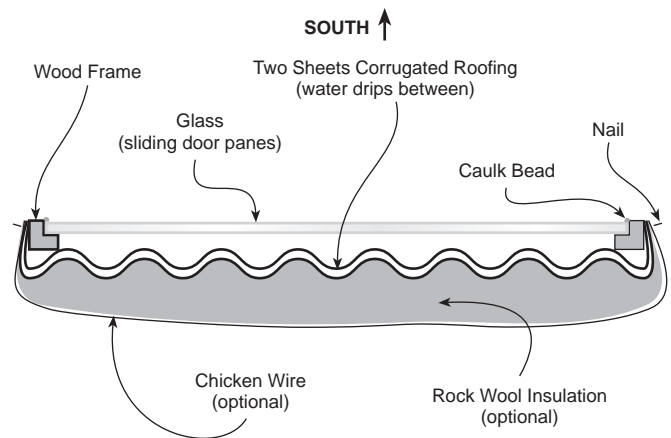

sump. It's a good idea to leave a bottom margin for loose crud to settle.

Place a float valve near the top of the sump, and connect it to your drinking water source. You can use a toilet bowl fill valve, but a livestock watering tank valve is more heavy-duty. Fresh water runs through the float valve until the sump fills up, then the valve shuts itself. If any water in the system evaporates or drips away, the float valve keeps the sump full.

Water from the sump pump runs through one inch pipe under the floor of the space you want heated. If you don't already have pipes under your floor, try routing the heated water through a large truck radiator. This indoor radiator could be hung on a wall with a fan behind it or

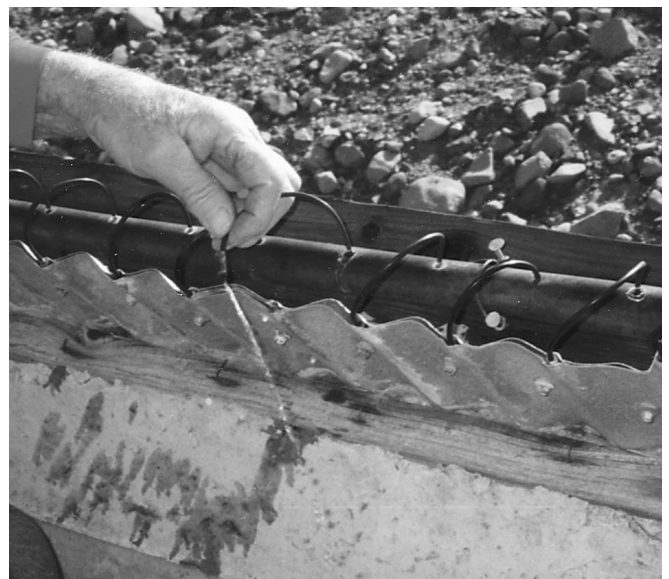

Above: Drip hose in action. Hose is tucked between pairs of corrugated metal sheets, and water gets heated as it runs down.

## System Layout

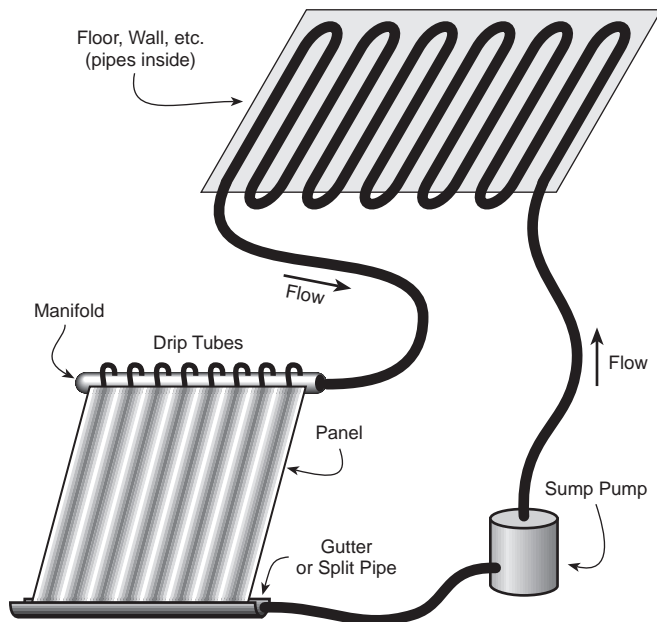

could be retrofitted into the bowels of an emasculated furnace for warm air circulation.

Return water from the house goes to a black plastic pipe manifold atop the panels. Punch a hole with an awl every few inches along the manifold, and insert a small length of drip irrigation tubing. You might need to insert hollow brass reinforcements inside the drip tube ends to keep the big manifold tubing from squeezing the little tubes shut. Stuff the loose ends of drip tubing between your pairs of corrugated metal sheets.

Water spreads out through capillary action to gather solar heat from between the two pieces of metal. Gravity carries the heated water eight feet to the bottom of the black painted metal roofing. When it gets there, it is around 140° F, and falls out into a length of rain gutter. The gutter conducts heated water back to the sump, completing the circuit.

Note there are no valves, thermostats, digital readouts, etc. When the pump is turned off, water circulation ceases and the panels drip dry, so there is no freeze problem.

### (In)Efficiencies

All you Phlogiston Police are upset about heat loss in the rain gutter and other places. Using this low-tech low-cost solution, it is more cost effective to add an extra water panel than to super-insulate. In fact, rather than calculate a bunch of BTU's, it is easier to join the Panel of the Month Club. Just add one panel at a time until you have as many as you really need. Chester keeps plenty warm with his ten panels, but maybe you

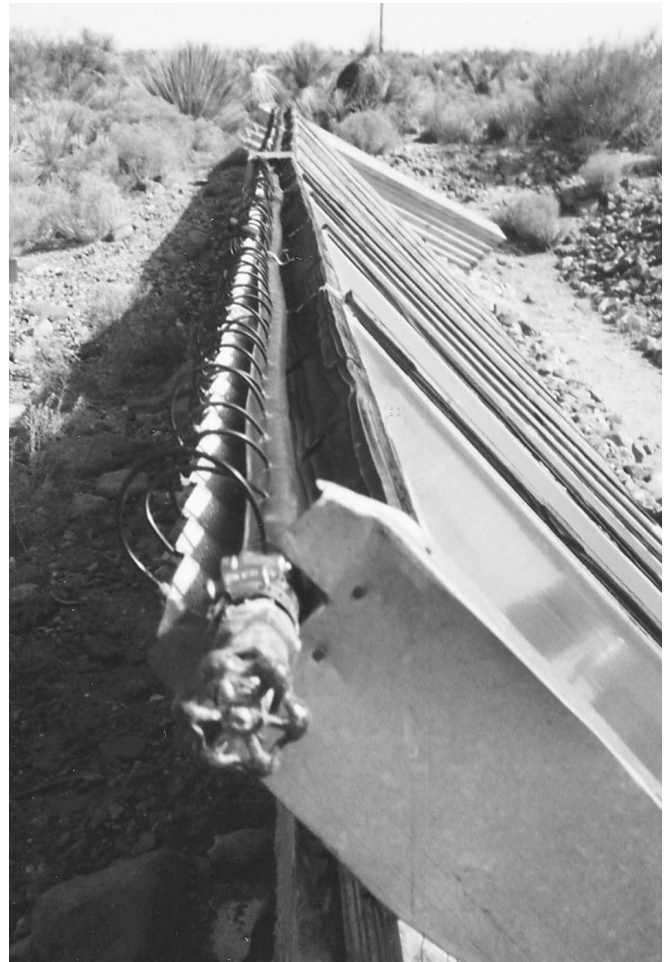

Above: Top view of solar collectors showing the water manifold.

don't get as much winter sunshine or maybe your house walls are thinner.

The first hot summer after installation, Chester's system suffered a melt down as the idle plastic pipes were overheated. A deliberately leakier glass mounting frame cured that problem, although some winter heat is inevitably lost to the improved ventilation.

### Variations

One variation on Chester's theme is to add a layer of rock wool insulation on the back of each panel supported by chicken wire nailed to the frame. This will reduce heat loss and is definitely a good idea if the back of your panel is exposed to breezes such as on a roof mounted system. If you decide to insulate your panels use something other than meltable plastic if your summers get hot.

For backup an option is to add a few water valves and occasionally reroute the water through an ordinary domestic hot water heater on long cloudy days and



Above: Ten home-made solar heat collectors. Water sump is at bottom left. Rain gutter runs along bottom of panels, and is covered by sheet metal and rocks to keep out critters and rain water.

dark cold nights. This is a second water heater pressed into infrequent closed loop house heating service, not your primary hot water faucet supply.

A third variation is to add yet more valves, a high pressure safety steam pop off, and run a few metal pipes through your fireplace or wood stove. Now you're cooking!

For architectural planning purposes, piping in liquified sunshine is a lot easier than planning big windows, massive floors, and trick pergolas. Smaller windows allow less summer heat gain and winter heat loss, and can be a security improvement, not to mention costing less to buy and install. Use common sense to decide whether to adapt Chester's very successful plan to your situation. If you have enough winter sunshine and not too much house heat loss, go for it!

#### Access

Authors: Chester Johnson & Joel Chinkes, c/o Home Power, PO Box 520, Ashland, OR 97520

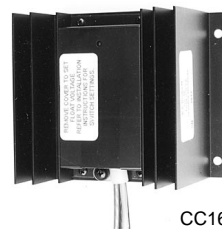

CC16

### Industrial Grade PWM Charge Controllers

Built for the  
most demanding systems,  
Priced for sensitive budgets.

16 or 32 amp, dual voltage 12 & 24 volts, for all battery chemistries, temperature compensated. Call your IPP for complete details.



## B. Z. Products, Inc.

7614 Marion Ct., St. Louis, MO 63143, USA

voice: 314-644-2490, fax 314-644-6121

e-mail: frank9966@inlink.com

# Do You Need Batteries?...

## RAE Storage Battery Company

Since 1943... Quality & Service

We're the nations LARGEST wholesaler of Trojan Batteries. Our family-owned business has OVER 85 years of "Battery Technology" experience.

Residential • Vacation • RV • Marine • Computer • Automotive  
Golf Carts • Wheel Chairs • Lawn Mowers • Fork Lifts  
Pallet Jacks • Remote Communications

If you need Competitive Pricing & Prompt Delivery  
then call:

**860-828-6007**

Fax 860-828-4540

51 Deming Rd., POB 8005  
Berlin, CT 06037



**Trojan**

**Talmage  
Solar Engineering  
Inc.**  
Att. Dept. A 18 Stone Rd. Kennebunkport, ME 04046

22 years of  
reliable service  
to New England's  
independent and utility  
interfaced solar needs.

We offer complete professional design and  
sales services at fair prices. Go with a team that  
knows the products and uses them daily.

Send \$2 for our comprehensive system design and  
products catalog and check out our web site for updates.

Call Toll Free: **888-967-5945**

web site: [www.talmagesolar.com](http://www.talmagesolar.com)

e mail: [tse@talmagesolar.com](mailto:tse@talmagesolar.com)

Full Line of Chest Style High Efficiency

## Solar Powerable Refrigerators & Freezers

Mix or Match 4 cu. ft. & 8 cu. ft.  
Cost Competitive Units.

NEW 8 cu. ft. Tropical Freezer  
(almost double the Insulation)

Coming Soon! 7 cu. ft.  
Refrigerator with Freezer.

Options: 12 VDC, 24 VDC, 120 VDC, 120  
VAC, Top Laminate Colors, Dual Controls  
& Water Preheating Condenser

Send for Information Packet...

## LOW KEEP REFRIGERATION

24651 Second Ave., Otsego, MI 49078

Web: <http://www.macatawa.org/~chinax/lowkeep.html>

See You At  
MREF '97

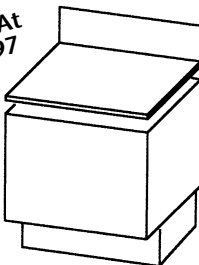

Phone  
**(616) 692-3015**

## Specializing in COMPLETE systems design

Solar Electric, Heating, Water, & Appliances  
Including complete CAD design services

We can supply everything  
you need to be off-grid...  
inverters to modules to  
batteries, including your  
kitchen stove

TRACE • KYOCERA  
APT • BUDERUS  
THERMOMAX  
WATTSUN  
SOLARJACK • IBE  
PEERLESS-PREMIER  
GAS RANGES



**TRACE  
ENGINEERING**

## PLANETARY SYSTEMS™

P.O. Box 9876  
2400 Shooting Iron Ranch Rd.  
Jackson, WY 83001

Phone / Fax 307-734-8947



Free Catalog  
to Home Power Readers

## WINDSTREAM®

### WIND GENERATORS

FOR DC, AC  
BATTERY CHARGING,  
WATER PUMPING,  
AERATION



FOR COTTAGE,  
RESIDENTIAL,  
MARINE, RV,  
TELECOM AND  
WIND - SOLAR  
APPLICATIONS

BUILT TO LAST!

### WIND TURBINES FOR ALL USES

SOLD WORLDWIDE

CONSTRUCTION PLANS,  
KITS AND ALL PARTS  
AVAILABLE

### HAND AND PEDAL GENERATORS

MICROHYDRO SYSTEMS

### PERMANENT MAGNET GENERATORS AND ALTERNATORS

## WINDSTREAM POWER SYSTEMS INC.

ONE MILL STREET  
POST OFFICE BOX 1604-HP  
BURLINGTON, VT 05402-1604

TEL 802 658 0075  
E-MAIL [windstrm@ix.netcom.com](mailto:windstrm@ix.netcom.com)  
FAX 802 658 1098

MANUFACTURING WIND AND WATER POWER SYSTEMS SINCE 1976

## THE SOLAR BOILER™

### State-of-the-Art Solar Water Heater

- PV powered, drain-back system
- Uses no ac electricity or controls
- Pre-assembled pump/heat exchanger module
- No pressurization/evacuation
- One day installation; no special tools required
- 10-year warranty all major parts



Call today for complete information on our ready to install  
solar thermal, pool heating, and solar electric home power  
systems. Dealer inquires welcome.

## Solar Works, Inc.

64 Main Street, Montpelier, VT 05602  
Tel: (802) 223-7804 Fax: (802) 223-8980



# Solar Energy International



**Knows Wind Power**



**For Course Information & Catalog**  
 voice: (970) 963-8855 • fax: (970) 963-8866  
 e-mail: sei@solarenergy.org  
 web: www.solarenergy.org  
 P.O. Box 715, Carbondale, Colorado, USA 81623

*We sell them all...  
 Because we've flown them all!*

**We'll See You  
 at the  
 MREF '97  
 in Amherst, WI  
 June 20-22**

Write or call  
 for the world's best prices on...

- BWC 850
- BWC 1500
- 10 kW Excel from Bergey Windpower Co.
- All Whisper models from World Power Technologies
- Tilt-up tower kits for wind generators
- Jacobs 29-20 from Wind Turbine Industries
- Windseeker 500 & "AIR" from Southwest Windpower
- Balance of System Components
- Wind / PV Hybrids

**We Pay Shipping to the Lower 48 on Most Items**

 **LAKE MICHIGAN  
 WIND & SUN**  
 3971 E. Bluebird Rd.  
 Forestville, WI 54213

**414-837-2267**

Fax: 414-837-7523  
 E-Mail: LMWANDS@ITOL.COM  
*"Wind generators & parts made with wind-generated electricity"*

# Track Rack™

**Passive Solar Tracker for Photovoltaic Modules**

Dependable as gravity. Reliable as sunshine.  
 Proven in climates around the world.

- Captures 98% of available solar energy
- Improves energy performance by up to 40%
- Nearly 8000 installed since 1980 with 99% still in operation
- Ten-year Warranty

**Call Today!  
 1-800-279-6342**

**ZOMEWORKS CORPORATION**  
 Passive Solar Energy Products  Since 1969

© Zomeworks Corporation



## Solar Baking Under the Sonoran Sun

Laurie Stone

©1997 Laurie Stone

**W**alk down almost any city street in Sonora, Mexico and you're likely to see bakeries filled with sweet breads, empenadas and Mexican cookies. Ciudad Obregon is no different. In a small, poor neighborhood on the outskirts of Ciudad Obregon (a city of 400,000), a group of women have started their own bakery. Along the dirt roads of Aves del Castillo and under the heat of the Sonoran sun, this small group of women make and sell their own breads and empenadas. These women are taking a different approach—they're baking with the sun.

Two years ago, Ken Olson and I, of Solar Energy International (SEI), had the pleasure of visiting Aves del Castillo. Through the Tucson based Farmer to Farmer organization and the Sonoran branch of Save the Children (FAI), we were introduced to a woman's group called Mujeres Activas (Active Women). And active they are. These women, from one of the poorest neighborhoods of Ciudad Obregon, have not let their economic problems impede their desire for an improved quality of life. With the help of FAI, Mujeres Activas have held nutrition clinics, started a program to sell soy products, learned to build straw-bale houses, and have been building and cooking with solar ovens.

There is a great need for employment in Aves del Castillo. The women of Mujeres Activas were looking for a micro-enterprise that could help support their families. Of all the different possibilities presented before them, they felt a solar bakery could best meet their needs. And having solar cooked for their families for months, they were already hooked on solar cooking.



Above: Cutting the wood for the oven frame.

Photo by: Cholla Eaton



Above: Making templates of the oven so it can be easily replicated.

Photo by: Cholla Eaton



Above: The basic oven box.

Photo by: Cholla Eaton

For the next two years while we looked for funding, the women worked out their plan. They decided who would be involved, what they would bake, and how they would advertise. With the help of the Tides, Greenville, and International Foundations, SEI was able to return to Ciudad Obregon to help the women with the solar oven. Ed Eaton, Cholla Eaton (Ed's daughter and our trusty photographer), Laurie Loeb, and I, all of SEI, headed down to Sonora to meet the women involved, teach them to build commercial size solar ovens, and try out numerous solar baked mexican pastries.

**The Oven**

Ed had designed a large commercial size solar oven which we use to bake cookies at our local summer fair. With adjustments to the materials and the angle of the glass we had a great model for the bakery in Sonora.

We built two ovens for the Aves del Castillo bakery. The first one was built at our office in Colorado. We made this oven into a kit for easy assembly. This made it much simpler to teach all the steps involved in building the oven while we helped them put together the kit. It also made the second oven, built from scratch in Ciudad Obregon with local materials, come together quicker than we could have ever imagined.

Each oven is 76 by 34 inches to accommodate a standard sized glass pane. They are made of 3/4 inch

plywood and ductboard insulation. The double pane tempered glass is angled at 30° (the latitude of Ciudad Obregon is 28°). There are two side reflectors (40 by 42 inches), angled at 60°, and a back reflector (76 by 42 inches) which hinges so it can be adjusted to any angle depending on the season and time of day. The reflectors are covered with Everbright, a shiny aluminum. The ovens are divided in half with a door on the back side of each. We have found in our cookie baking experience that using a fan to circulate the air does wonders for cookies and pastries. We included one PV powered fan in each side of the oven. The fans are run by a 6 Volt, 5 Amp module.

The ovens are on stands with wheels on the bottom to accommodate easy tracking of the sun. A local carpenter built the stands along with an adjustable rack to hold the PV panel. When the ovens are not in use the panel folds down out of the way, and when in use it can be tilted to varying angles.

Building the ovens couldn't have gone smoother. There are four women involved in the bakery, but on the first day of the oven building eight women showed up. They told us they weren't all



Above: Attaching the doors for the oven.

Photo by: Cholla Eaton



Above: Working on the oven box.

Photo by: Cholla Eaton



Above: Patricia attaching the Everbright to the reflector.

Photo by: Laurie Stone

## Solar Cooking



Above: Julia, Guillermina, and Rosario working on the oven.

Photo by: Cholla Eaton



Above: Siliconing the oven.

Photo by: Cholla Eaton



Above: Attaching the Everbright to the reflector.

Photo by: Cholla Eaton

part of the official bakery group but were eager to learn about building ovens. They asked us if it was okay if they helped out. We were ecstatic that more people wanted to learn about solar cooking. During the next few days many people stopped by to pick up a hammer, sketch out the oven plans, or just watch this huge solar oven being built.

On the first day we had barely pulled out the tools before the women were hard at work. Their energy and enthusiasm made the first oven come together in a day and a half. We thought that building the second oven from scratch would take much longer, yet the women knew exactly what to do and were so eager to get the oven built they didn't want to stop working. One day after getting the main box put together and the insulation put in, we left for our lunch break. When we came back three hours later (many Mexicans like long lunch breaks to avoid working during the hottest part of the day), we were surprised to see that Rosalinda and Lupita had not even left for lunch. They had worked straight through and both of the side reflectors were now on the oven. At that rate it only took two days for the second oven to be ready for cooking.

### Empenadas and More Empenadas

Now, with the ovens built, came the hard part—learning to run a business. The first thing that needed to be

done was to test out the recipes in the ovens. The next three days were spent making empenadas filled with squash or strawberry jam, cookies, breads, muffins, pizzas, and coyotas (a Sonoran staple, a large flat pastry filled with brown sugar). We, of course, had to be the tasters to make sure all the recipes were up to par. They were delicious! Every day the women also cooked lunch for everyone in the ovens, making rice, fish, pizza, and steamed vegetables.

During those next days we also discussed the follow-up to the project. We provided the women with a weekly form to be filled out. The forms are to be used to keep records of the bakery and for us to keep track of how the bakery is doing. It asks questions such as:

- How many of each type of pastry or bread was made each day?
- How many customers did you have each day?
- How many people worked and how many hours were worked each day?
- How much money was spent on ingredients weekly?
- What was the weekly profit?
- What problems, if any, did you have with the oven?
- What new things were tried?

The women already have an advertising plan worked out. They are going to hang up and hand out flyers



Above: Rosalinda attaching the sides of the oven.

Photo by: Cholla Eaton



Above: Three of the children working on the doors.

Photo by: Laurie Stone



Above: Everybody working on the oven.

Photo by: Cholla Eaton



Above: Rosalinda and Lupita varnishing the finished oven.  
Photo by: Cholla Eaton



Above: The bakery crew in front of the two finished ovens.  
Photo by: Cholla Eaton



Above: Making empanadas and coyotas.  
Photo by: Laurie Stone

throughout the neighborhood and advertise on the local radio station. Dora Elia, a woman working with FAI, is going to teach them about accounting. SEI provided the women with a loan to buy any baking equipment they might need such as bread pans and cookie trays. FAI is providing them with a location for the bakery. Any profits they make, after they pay themselves a decent salary and pay off their loans, will be reinvested in the bakery to build more ovens, build a nicer space for the bakery, or even expand to open a cafe. They are also thinking of building and selling smaller family size ovens to people in Aves del Castillo and neighboring communities.

**Solar Baking Significance**

The bakery was to open at the end of March. The women of the solar bakery will not only be earning much needed salaries, they will also be spreading the word about solar cooking. Micro-enterprises like the Aves del Castillo solar bakery have far reaching consequences. Now that the women are earning money their children can go to school, they can provide their families with shoes and clothes, and they don't have to worry about whether they will be able to put food on their plates.

This model micro-enterprise also has significance world wide. The women of Aves del Castillo have proven that

with some will, determination, and sunshine, people can improve their quality of life. There are people all over the world who could benefit from a solar business like this bakery. Although most solar projects in developing countries focus on rural areas, there is also great need in the cities. Unemployment is high in the developing world. Often people from rural areas flock to cities in search of employment, only to find themselves living on the streets with the rest of the unemployed. Reducing the appeal of urban life by bringing electricity to rural areas is one way solar energy can improve people's lives. But creating employment in cities is another way to better people's lives which cannot be overlooked.

The Sonoran commercial solar ovens are sure to bake up hundreds of empenadas and coyotas. However, there is much more to running a successful solar bakery than a hot solar oven. The enthusiasm, competence, and devotion of these women is sure to make Ciudad Obregon's (if not Mexico's) first solar bakery a huge success.

**Access**

Author: Laurie Stone, Oven designer: Ed Eaton, Solar Energy International, PO Box 715, Carbondale, CO 81623 • 970-963-8855  
Fax: 970-963-8866 • E-Mail: sei@solarenergy.org  
Web: www.solarenergy.org



Above: Watching the empanadas bake.  
Photo by: Laurie Stone



Above: Rosalinda with some fresh baked cupcakes.  
Photo by: Laurie Stone

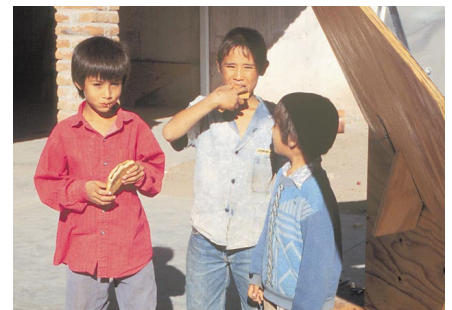

Above: Enjoying the empenadas fresh out of the oven.  
Photo by: Cholla Eaton

# Electricity From The Wind & Sun



Utility Intertie Systems. (The 1st in the UK)

Stand Alone  
& Remote  
Home  
Systems

UK  
Distributors  
for Home  
Power  
Magazine



11 years experience; our office, showroom, and workshop are wind & solar-powered.

Marlec, Wind Baron, Proven, Bergey and Vergnet wind turbines; Siemens, BP Solar and Solarex PVs; Powerstar, Trace, ASP sine wave and SMA utility intertie inverters; Oldham and Exide batteries. Also: Wattsun Trackers, APT Powercenters, ShurFlo pumps, low voltage lights, appliances and much more.



## Wind & Sun

The Howe, Watlington  
Oxford, OX9 5EX  
United Kingdom

TEL. (44)-1491-613859

FAX (44)-1491-614164



Send for our Design  
Guide & Catalogue:  
Price £5.00 in the  
UK (add £1.00 for  
overseas postage).

# Renewable Energy on CD-ROM



For Alternative Energy Fans,  
Businesses, Researchers and  
Educators. PC/MAC/UNIX

Reports, Articles, Newsletters, Programs and  
Graphics on PVs, Wind, Hydro, Controls, EVs,  
Biofuels, Environment and Sustainable Systems

Article Text and Graphics from  
Home Power Magazine #1-#36

Includes: 250 Megabytes of Shareware and PD  
Software for Macintosh® and PC Compatibles

Home Power

PO Box 520  
Ashland, OR 97520  
916-475-0830

**\$29<sup>00</sup>**  
ppd

International Orders  
Add \$3



For Credit Card Orders Call Home Power at 800-707-6585

# HOME POWER T-Shirts

100% Cotton = Good Shirts

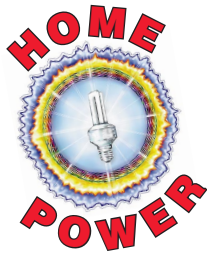

Full Color on White Shirt  
**\$15.00**



Full Color on Black Shirt  
**\$20.00**  
(they cost more to make)

Sizes:  
S, M, L, XL, XXL

**To Order Call: 800-707-6585**

916-475-0830 Outside USA

-or-

Send Check or Money Order to:

Home Power Magazine

PO Box 520

Ashland, OR 97520

-or-

See Our Web Site: [www.homepower.com](http://www.homepower.com)



## NO-HASSLE WATER POWER

If you have a reasonably fast running stream or tide nearby and 12" of water clear, Aquair UW Submersible Generator can produce 60 to 100 Watts *continuously*, up to 2.4 KWH per day. **NO TURBINES, NO DAMS, NO PIPES!** Water speed 5 mph (brisk walk) = 60W. 8 mph (slow jog) = 100W. Timber, rock, or natural venturi increases output.



12 or 24  
VDC

**Jack Rabbit Energy Systems**

425 Fairfield Ave., Stamford, CT 06902  
(203) 961-8133 • FAX (203) 358-9250

## Solar Energy International



**Knows Energy-Efficient  
Building Tech.**

**For Course Information & Catalog**

voice: (970) 963-8855 • fax: (970) 963-8866

e-mail: [sei@solarenergy.org](mailto:sei@solarenergy.org)

web: [www.solarenergy.org](http://www.solarenergy.org)

P.O. Box 715, Carbondale, Colorado, USA 81623

PROVEN RELIABILITY THROUGHOUT THE WORLD Stationary Diesel Powered



ACME  
north america



ACME  
north america

ACME  
north america

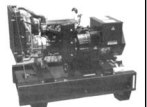

DC Versions: 12 to 32 VDC **GENERATOR SETS** Kerosine Fired: 2 to 6.5 KW  
Gasoline, Kerosine, & LPG Powered Diesel Powered  
1.5 through 10.5 KW 2.8 through 10.5 KW

**ELECTRIFYING SOLAR ENERGY**

P.O. Box 681394HP

409-894-2074

Houston, Texas 77268

For Solar Info

FAX 409-894-3607

See Micro Ad



# Running The Minnesota Solar Boat Regatta

Ralph Jacobson & Tom Roark

©1997 Ralph Jacobson / Tom Roark

**A**dvance scouts for renewable energy have plied Minnesota's lakes since 1992. The scouts are high and middle school technology students, piloting solar-powered boats built in class. The Minnesota Renewable Energy Society (MRES) has organized all but the first of the Regattas and hosted the Junior Solar Sprint model car competition as a companion event.

Larger Minnesota renewable energy projects include multi-million dollar wind farms in the state's southwestern corner and the brilliant "Green Streets" exhibit at the Science Museum of Minnesota. But it's hard to beat the Regatta/Sprint for color, educational value, and a youth-oriented family atmosphere. It is a hands-on grassroots effort in which volunteers, teachers, and, most of all, students work with and exhibit the technology which will take our sorry economy into the 22nd century.

## Rules

The Solar Boat Regatta is an educational event, and the atmosphere is something between a "Little Rascals" romp and a science fair. Rules and judging are designed to force teams to operate on power from solar panels and to consider their boats as real world systems that need to use power frugally.

Boats may be built from scratch or may use modified commercial hulls. The field runs from commercial canoes balancing solar panels, kids, batteries, and trolling motors, to sleekly sculpted polystyrene dreams with inlaid photovoltaic panels. MRES wants teams to

compete with peers so there are four classes of entry. Middle schools use 150 Watt panels and either build their hulls or modify commercial hulls. Senior high teams use either 150 or 300 Watt panels. Boats are limited to two lead-acid batteries with a combined capacity of 220 Amp hours at 12 Volts or 110 Amp hours at 24 Volts. There's no on-shore battery charging or swapping. Boats are inspected by the US Coast Guard and carry fire extinguishers and Minnesota registration. Boats must be piloted (no remotely controlled boats) and pilots must be swimmers and wear life preservers.

Teams post presentation boards including school and team-member names, plans, photos, and text about their boats. Teams also make oral presentations. In 1996, Minneapolis' North Community High said that they had designed their "Solar III" as a third world mini-freighter and St. Paul's Como Park Senior High School thought of their "Solar Splash" as a solution to the noise versus access dilemma faced in Minnesota's Boundary Waters.

## Events

There are four events, and boats are encouraged to run in all four. In the Speed Race the boats race a designated straightaway in small heats with the fastest time winning. In the Endurance Run the boats circle an island for two hours. The boat that runs the most laps wins. In the Maneuverability Race each boat slaloms through a course of buoys while trying not to touch them, the nearby shore, or take on water. The fastest time wins. The toughest event is run without batteries. Powered directly by their panels, the boats repeat the speed race. The '96 event was held on a drizzly, overcast day, but four of the teams managed to creep through the course, using panels only.



Performance in these events counts for 50% of each team's total score. A team of five to seven judges evaluates maneuverability, innovative design, hull form, hull/pv compatibility, and material selection. Spectators vote on aesthetics. These evaluations make up the other 50% of the teams' scores. Judges acknowledge the creativity and effort that goes into each boat, because every boat in the Regatta represents the promise of its teenage engineers.

### History

The Minnesota Solar Boat Regatta has been growing steadily since its beginning in 1992. It had nine teams then and eleven teams in the '96 event plus several out-of-state inquiries, leading MRES to believe that there are nascent Solar Boat Regattas elsewhere (MRES is eager to help them). In 1994 MRES began holding the Junior Solar Sprint alongside the Regatta. This has added interest and made a larger event. Crowds have grown over the years from family and passersby at the beginning to committed fans and television news cameras in '95 and '96.

Many personalities have shaped and organized the event. Hartmut Ginnow, an Industrial Design instructor at the Minneapolis College of Art and Design, built a solar boat and was featured in one of the local papers. John Anderson, a Technical Arts instructor at Minnetonka Senior High School saw the article featuring Hartmut and contacted him about holding a competition.

Anderson had an interest in solar power and a history of finding projects to get his students excited about learning, including Minnesota's High-Mileage Vehicle Race and various solar demonstration projects. In an effort to expose his students to as wide a variety of solutions to the problem of designing a solar boat, Anderson decided to open up the Regatta to anybody who wanted to enter and advertised in national solar

energy publications. Nine boats, including one from Marquette University and one built by a Tennessee family, came to the United States' first Solar Boat Regatta.

Ralph Jacobson, a Twin Cities builder, photovoltaic dealer, and MRES Board Member, remembered the difficulty he'd had learning electricity in high school and made sure that all the participants in his solar charging seminar were up to speed about watts and volts first by giving a short basic electricity course. Other organizers' workshops give teams basic information about hull, propulsion, electrical, and solar design.

### Organizing and Sponsorship

As soon as the last boat is loaded on its trailer, there's a sense of relief and accomplishment. Another Regatta/Sprint has come and gone, but organization for the next year's event begins right away. Thank you letters go out to supporters, evaluations from teachers need to be read and acted on, and the organizers need to debrief each other. Workshops and presenters for next year's teams are coordinated. Organization is year-long operation for MRES. Volunteers put in hundreds of hours each year. They ask businesses, foundations, and friends for money to fund the Regatta/Sprint, arrange with the City of St. Paul for use of a site, and negotiate the best insurance deal. They also publicize the event, writing press releases and speaking to the press.

The amount of time teachers and students spend preparing for the Solar Boat Regatta ranges from "pretty much" to entire class years. Building a solar boat is as simple or complex as you want to make it.

Rudy Chmelik, of Hastings Senior High, uses the Regatta as a Spring Quarter Technical Arts project and would like to go all year. He says, "(In 1998) I want to divide into two teams in the fall. One would build a solar





boat, and the other would build a high-mileage vehicle. Each team would treat its task as a complete engineering project. You have time, money, knowledge, materials, and a deadline."

Ryan Sanford, a junior at Hackensack-Walker-Akley Senior High School, built his school's entry single-handedly. Ryan spent 350 hours on the project, more than 200 of them sanding, patching, and painting his salvaged catamaran's hulls.

School budgets being notoriously tight, official financial support for Solar Regatta projects is rare. Teachers and students spend a lot of time fundraising for their boats. Allan Meyer of Apple Valley Middle School approaches potential sponsors personally, sending out letters and press releases with pictures and making a lot of phone calls. John Lindquist, the Pillager Senior High School sponsor, has his students price materials and write a budget. Then students write to potential sponsors with guidance and correction from their English teacher.

Jeff Bunkert, the teacher who sponsored the Valley View Middle School team, challenged other teams to match their accomplishment of building a boat for \$200 and in under two months. Valley View borrowed panels and another teacher's canoe, and were given wire, loom, and odds and ends by a local hardware store. They used two \$100 donations to buy batteries and life jackets.

Rudy Chmelik sees fundraising as part of the total engineering project and says that one of the lessons his students learn is how to talk to adults. He says, "They dress up and talk to civic groups. When the groups receive effective presentations from kids, they're usually generous." His students have produced posters, a five-minute video, and sell "Solar Boat" buttons as part of their campaign. The funds from the button campaign are being matched by a department store.

The Solar Boat Regatta is a valuable tool for reaching and teaching kids. This is a problem-solving project. Students who build solar-powered boats take that experience into other classes, and carry it with them in later life. The problem-solving comes because teams have to satisfy judges who are looking for boats that are designed so their different parts work well together. The teenaged engineers wrestle with the problems of designing boats that float a cargo and crew of up to 500 pounds, travel with minimum friction (the maximum speed of a boat in miles per hour will be approximately 1.4 times the waterline length of the boat in feet), and still be maneuverable. They do all this within the time and financial limits of high school social clubs. Kids who build the boats work with solar technology and learn at least one reference for solving future energy problems

without falling for the notorious false dilemmas associated with energy and the economy. In a time when it's loudly wondered why kids aren't being better educated, they are lining up to take the class where you build the solar boat. They are all pumped up about their boats, learning a lot of subtle teachings. Those teachings have to do with—ugh—math, physics, and engineering.

### Education

The Solar Boat Regatta is a valuable tool for reaching and teaching the public, too. It's an example of solar technology working conspicuously, in a city park, one day in June. People see the boats there and local television stations send cameras. The boats are proudly displayed at school, in hometown papers, in local parades, and at the state fair. They're built by students, and that leads to two notions: students are learning exactly the kind of skills that educational critics say are missing in today's schools and solar technology isn't the obscure, impossible dream we've been told (it's child's play). Students take to this project eagerly, and parents and teachers are swept along in their wake.

The Solar Boat Regatta/Junior Solar Sprint is an attractive, growing event. In a boat-happy state like Minnesota, the teams build colorful, fantastic boats. MRES has a team of committed volunteers who spend a lot of time publicizing and managing the event. In '96, the Science Museum of Minnesota came on board as a sponsor, providing a lot of help with copying and publicity. According to Chuck Penson, director of the museum's computer education center, "Something like copying, which is a big deal for a small organization, is nickle and dime for sizeable company." The Regatta is beginning to make these important connections, and with the Twin Cities' affection for big civic parties like the Minneapolis Aquatennial and the St. Paul Winter Carnival, the Solar Boat Regatta and Junior Solar Sprint may become the kernel for another of those celebrations.

This year's Regatta happened on May 31.

### Access

For further information about MRES's Solar Boat Regatta, contact authors Tom Roark at 612-721-2103 or Ralph Jacobson at 612-647-0758  
Web: [freenet.msp.mn.us/ip/env/mres](http://freenet.msp.mn.us/ip/env/mres).

Photos by Tibb Wozniak and Julie Jozwiak

### Home Power's special kudos to these Regatta folks:

John Anderson, a Technical Arts instructor at Minnetonka Senior High School

Brad Buxton, of Midwest Boat Builders

Steve Dess, MRES member

John Dunlap, a solar engineer with Minnesota Department of Public Service Energy Division

Hartmut Ginnow, former industrial design instructor at Minneapolis College of Art and Design

Amy Hoagberg, former 3M engineer

Ralph Jacobson, a Twin Cities builder, photovoltaic dealer, and MRES Board Member

Martin Lunde, a mechanical and structural engineer and a lifelong boating enthusiast

Chuck Penson, director of the Science Museum of Minnesota's Computer Education Center

Tom Roark, MRES member



## STOP WASTING HEAT!

Your refrigerator produces much of the heat necessary to heat your water supply. **The Heat Saver Manual** explains how to install an inexpensive, easy to make system which doesn't require the release of freon.

Send \$5.95 to

**APM Technology**

PO Box 1772 Santa Monica, Ca 90406

## ELECTRIC CAR COMPONENTS & KITS

- \*Reliable, Affordable Components
- \*Large Library Of Adaptors
- \*Most Experienced Tech Support
- \*Design Assistance

### Conversion Kits:

#### \*Basic & Deluxe Universal Kits

Contain all drive system components. You add mounts, boxes, etc. to fit your model.

#### \*Complete Custom Bolt-In Kits

*Voltsrabbit* for VW Rabbit, and *Voltsorsche* for Porsche 914. Completely prefabbed. No design or welding necessary. Kits include everything except donor car & batteries.

For Catalog, Send \$6.00 To:

**ELECTRO AUTOMOTIVE**  
**POB 1113-HP**  
**FELTON, CA 95018**



(Outside the U.S. & Canada, add \$5.00)

# Kansas Wind Power

## Food Dehydrator & Sprouter

Non-electric, noiseless. Dry fruits, veggies, meats. Sprout seeds. Hang it outdoors or in kitchen for convenience. Has five 1 foot square trays. Fine mesh netting protects food. Stores in compact 3"x15"x15". Sells nationally for \$90.

**Sale! only \$25 or 6 for \$21 each**



Shipping Extra on sale Items

\$4 Independent Power Catalog

\$3 Bulk Food Catalog

\$5 Windmill Water Pumper Catalog

Kansas Wind Power,  
Dept HP59, 13569-214th Road,  
Holton, KS 66436

"Since 1975" 913-364-4407



# Hydroelectric

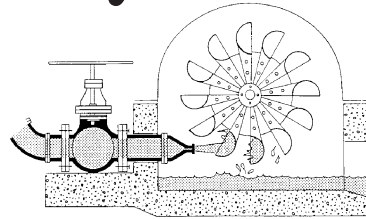

**Micro-Hydro:**  
Turbines  
Site Analysis  
Equipment  
Installation

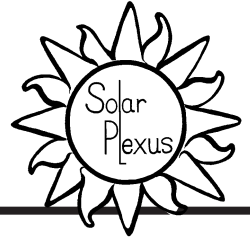

## Solar Plexus

130 W. Front St.  
Missoula MT 59802  
Phone / Fax: (406) 721-1130  
[www.marsweb.com/solplex](http://www.marsweb.com/solplex)

# SIEMENS

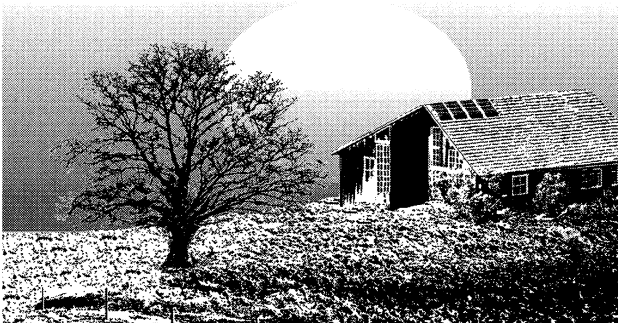

## Solar Power Your Dream.

You've finally found just the right spot. A little out of the way, but good water, good soil, and even a little view. You're going to build.

Find out now just how easy it is to have a solar system to meet all or part of your electrical needs.

See Your Siemens SolarPowerPro™

Siemens can help turn your plans into reality. An economical Siemens solar system can give you year after year of trouble-free electricity. And do it silently, without fuel, waste or pollution.

Office (520) 636-1001

Fax (520) 636-1664

P.O. Box 365, 2655 N. Hwy 89  
Chino Valley AZ 86323

# ELECTRIC VEHICLE

COMPONENTS, CONVERSION KITS, PUBLICATIONS, VIDEOS, AND ENGINEERING DESIGN SERVICES FOR THE EV HOBBYIST AND MANUFACTURER...All components selected with safety and reliability foremost in mind....We stock and sell the largest variety of the very best:

- ◆ ADVANCED DC Motors in 9 variations from 2 HP to 28.5 HP
- ◆ CURTIS-PMC Controllers, Throttle Potboxes, Footpedals
- ◆ ALBRIGHT ENG. Main & Reverse Contactors in 6 models
- ◆ GENERAL ELECTRIC & HEINEMANN Circuit Breakers
- ◆ BUSSMAN Safety Fuses from 200 to 800 amps
- ◆ DC-DC Converters from 48 to 200 V input
- ◆ K & W ENG. & BYCAN Battery Chargers from 48 to 144 V
- ◆ Full line of CURTIS, WESTBERG, & KTA Meters & Gauges
- ◆ DELTEC Meter Shunts from 50 to 1000 A
- ◆ EVCC Adapter Plates, Couplings, Clamps, & Brackets
- ◆ PRESTOFLEX Welding Cable, MAGNA Lugs, Assy. Tools
- ◆ CONVERSION KITS for vehicles from 300 to 5000 lbs.
- ◆ Complete ELECTRATHON Drive & Instrumentation Pkg.
- ◆ 3 Complete GO KART kits...for up to 90 mph..

COMPONENTS & PUBLICATIONS CATALOG.....\$5.00

## KTA SERVICES INC.

Electric Vehicle components and systems since 1984

944 West 21st Street – Upland, CA 91784 USA

Tel: (909) 949-7914 – FAX: (909) 949-7916



**HITNEY SOLAR PRODUCTS, INC.**  
Harmony with Nature

# Phoenix Composting Toilet System

*An economical and environmentally sound method of waste treatment for homes, cabins, campgrounds, and parks.*

- The *Phoenix* is odorless, rugged, and has a long and uniform retention time.
- All toilets are easy to use — but only the *Phoenix* is easy to maintain.

Advanced Composting Systems  
195 Meadows Road • Whitefish, MT 59937  
406-862-3854 • Fax 406-862-3855  
phoenix@cyberport.net

Sunergy Systems, LTD  
P.O. Box 70 • Cremona, AB TOM ORO  
Canada  
403-637-3973

Now on the Internet! <http://www.compostingtoilet.com>

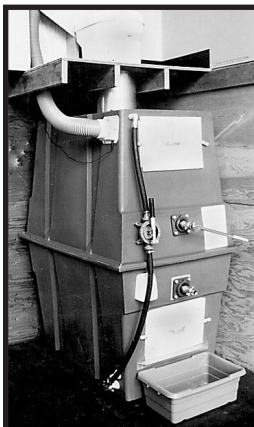

# No Power? No Problem!

From System Design to Installation...  
Renewable Energy systems for your home, RV, and lifestyle.  
**Electron Connection - Call Toll Free 1-800-945-7587**  
Photovoltaics • Microhydro • Windpower • Water Pumping  
Consultation • Site Survey • Installations  
CA Electrical Lic #613554



Authorized Distributor

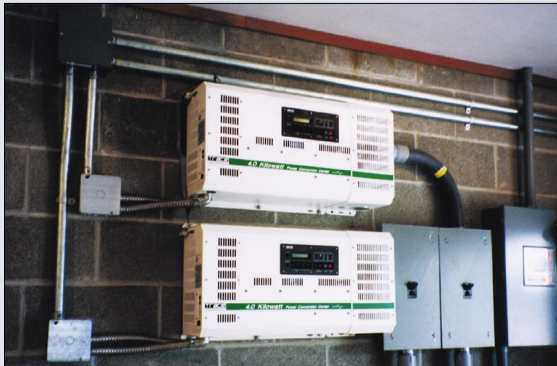

**Trace 4,000 watt Sinewave Inverter**  
Equally at home on or off the grid!  
Utility intertie and battery — the best of both worlds!  
Sophisticated, high output battery charger  
Clean and quiet sinewave power  
Over 90% efficiency and low idle power  
Now available optimized for alkaline batteries.



### Sun Spot™ Solar Oven

- \* Lightweight — 1¼ pounds!
- \* Portable — Backpackable!
- \* Expandable cooking chamber!
- \* Heats to 350°F!

**\$32 shipped free in USA**

CA Residents please add 7.25% tax.

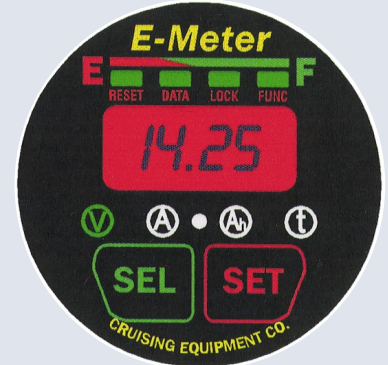

### Graphic and Digital Displays

- \* Digital Volt, Amp, Amp/Hr Meters
- \* Battery Temperature Compensation
- \* Monitors Battery Systems 12 to 500VDC
- \* Discharge Time Remaining Display for EVs
- \* Perfect for EVs, RVs, Marine, and AE Systems
- \* Stores Discharge Data, Efficiency, More!
- \* User Customizable Setup
- \* Price INCLUDES 500A Shunt
- Options
  - \* RS-232 output for computer interface
  - \* Remote relay output based on A/hrs

**In Stock — Call!**



- **Photovoltaics** — Solarex - Siemens - BP - Midway Labs
- **High-Quality Batteries** — Trojan - US Battery
- **Power Inverters** — Trace Engineering - PowerStar - Exeltech - AC Genius
- **Instrumentation** — Cruising Equipment - Fluke - Wavetek
- **Charge Controllers** — Heliotrope General - SunAmp - Trace
- **Trackers & PV Mounts** — WATTSUN - Zomeworks - Direct Power
- **Microhydro Electric Powerplants** — Harris Hydro - Lil Otto Hydroworks! - ES&D
- **Pumps** — Solar Slowpump™ - Flowlight - Solarjack - SHURflo - A.Y. McDonald
- **Water Heaters** — Myson - Aquastar
- **Efficient Lighting** — Phillips - Osram
  - Sun Frost • APT • Heinemann • Cutler & Hammer • Square D Products



♦♦♦ **DEALER/INSTALLERS!** ♦♦♦  
Anyone can sell you parts. We use and install the components we sell. We KNOW how they work and offer technical support, system design assistance, prompt shipment, fair pricing, and NO BULL. Electrical competence required. Find out why Electron Connection's dealers are prospering!  
Write today for your dealer application.



## Electron Connection

POB 203, Hornbrook, CA 96044 USA



VOICE • FAX 916-475-3401

Internet: [econnect@snowcrest.net](mailto:econnect@snowcrest.net)

Web Page: <http://www.snowcrest.net/econnect>

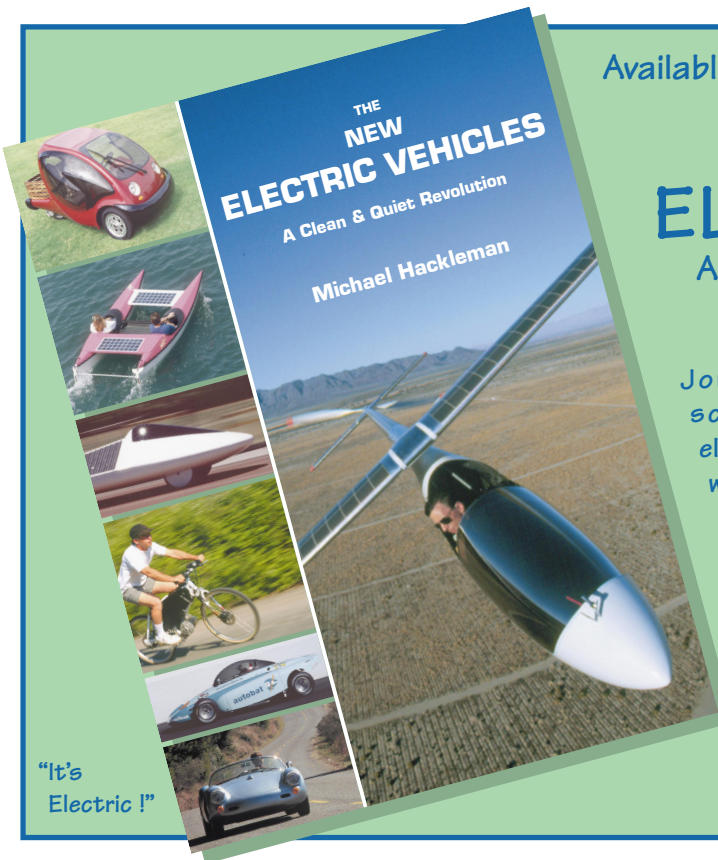

Available Now! Only \$25 (outside USA add \$5 for shipping)

## THE NEW ELECTRIC VEHICLES

A Clean & Quiet Revolution  
by Michael Hackleman

Journey into the world of conversions, scratchbuilts, human-electrics, solar cars, electrathon racers, planes & boats—all powered with electricity.

272 pages of EV technology, 465 photographs (over half in color), and detail on 65 vehicles. Includes 115 technical design and construction sidebars.

To order Call: 800-707-6585

Outside USA call 916-475-0830 • Fax: 916-475-0941

or write to:

Home Power Publishing  
PO Box 275 • Ashland OR 97520



**check your  
mailing label**

**The last issue of your subscription is printed in plain English  
on your mailing label. We rely on you to check your label!  
So check your label and don't miss an issue!**

# EV Tours & Rallies

Shari Prange

©1997 Shari Prange



Above: Falmouth Wattman team members celebrating with their *Electric Hare* at the 1995 NESEA American Tour De Sol finish line.  
Photo: Central Maine Power



Right: Solectra Corp. and friends celebrating at the finish line after capturing the U.S. Electric Vehicle Championship awarded by the 1996 NESEA American Tour De Sol.  
Photo: NESEA

**T**he oldest type of electric vehicle competition is not a race at all... It's the road rally. Rallying has been around just about as long as there have been cars, but the electric car crowd developed their own variation on the theme.

### Day Trippers

Rallies are the most casual and low-key type of event. This is not to imply that the competition doesn't sometimes get fierce. However, unlike most kinds of racing, rallies are open to just about anyone with an

ordinary electric car. No special roll cages, licenses, or helmets are required. Rallies welcome drivers who are just in it for fun, and there is plenty of that to go around.

A rally is run on public streets and highways, mixed in with normal daily traffic. Participants are required to obey all traffic laws, and cars must be legally registered for street use.

The typical rally course is a loop a few miles long. It is most likely to run on quiet in-town streets with stop signs, but it may include some country roads or freeways. Some rallies offer optional routes for higher performance vehicles. Vehicles may be divided into classes such as conversions, production EVs, two- and three-wheelers, and custom built vehicles.



Above: Bolton High School set the lead/acid range record of 143 mi. in 1995.

Photo: NESEA

### And They're Off!

The cars may be released all at once at the starting line, or they may be required to punch a time clock individually, or have a judge check off a lap record. As they circulate around the course, they will pass judges stationed at critical intersections. These judges mark each car's number on a lap chart each time it passes, or stamp a lap record carried by the car. By comparing all the lap charts at the end of the day, the judges can verify how many complete laps each car made. Partial laps in which the driver got lost or turned back early won't count.

The winner is not the car that finishes first, but the one that finishes the most laps in the allotted time. The early rallies were pure range events. In recent years, many have developed "point" formulas to include such things as efficiency, braking, handling, and acceleration tests. The overall focus of the event is on practicality in everyday driving.

In the early days, rallies sometimes turned into slow torture. Diehard competitors would conserve every amp by creeping slowly around the course for hours, refusing to quit until the car wouldn't go any more, or until it got dark and the judges quit in exhaustion. This defeated the purpose of displaying practicality, and gave a poor showing of EVs to the public.

The problem was cured by instituting some variation of a maximum lap time rule. Under this rule, any lap that exceeds a maximum time doesn't count. The maximum time is determined by the judges as an average lap

time in normal traffic speeds, allowing for stop signs or lights.

Of course, drivers are also forbidden to speed, but since they don't want to waste energy, this hasn't usually been a problem.

### Getting Out The Word

Rallies also serve as public education forums. They are often held in conjunction with public events such as Earth Day, and may require drivers to carry a passenger. This gives the public a chance to see and ride in electric cars.

Rallies are generally sponsored by electric car clubs or alternative energy organizations. The largest and best known club is the national Electric Auto Association. The EAA was founded in central California in 1967. It has waxed and waned with interest in EVs over the years, and

now has 34 chapters nationwide. There are many other regional clubs in the U.S. and Canada.

### Just Plain Folks

The cars in rallies are largely ordinary daily drivers. They use DC systems and lead-acid batteries, with packs between 96 and 144 Volts. They are conversions of small sedans and pickup trucks, usually built by the owner.

A few vehicles will be commercially produced EVs, such as old Citicars or postal Jeeps. A few may be bicycles, motorcycles, or three-wheelers. And a few will be highly customized individual creations. The most competitive drivers may have experimental components or systems. These usually involve some form of battery



Above: EAA elder statesman John Wasylina in his electric Renault.

Photo: Bob Wheeler



management, and are often more complex than the average daily driver would tolerate. However, the rally can accommodate the pleasure driver as well as the technophile.

### Long And Winding Road

A slightly different, but related, event is the tour. The tour also runs on public roads. However, instead of circling a loop for one day, it stretches in legs over multiple days in a one-way run from start to finish. This is a more challenging event.

The granddaddy of the EV tours was the Swiss Tour de Sol, now discontinued. Initially, it was an event for university-built solar race cars, but it expanded to include street cars with solar assistance.

In 1987, Dr. Rob Wills, then a graduate student, went to the Swiss Tour de Sol with the Dartmouth team. The experience inspired him to start a similar event in America. This became the American Tour de Sol, which is run each spring in the northeastern states by the Northeast Sustainable Energy Association (NESEA) under the guidance of directors Nancy Hazard and Dr. Rob Wills.

The first NESEA Tour, in 1989, had a field of five university solar cars. With the passage of the Clean Air Act, the event began to expand in 1990. James Worden, of Solectria in Massachusetts, has been driving since the first year, and Solectria entries have won more times than any other team.

### A Traveling Feast

The tour covers about 300 miles over the course of a week, with each leg being between fifty and seventy miles. In recent years, the legs have expanded in length and become more challenging, including significant hills, to keep pace with the improving performance of the cars. This year one leg exceeds 100 miles, with a three-hour mid-day, charging break.

If a vehicle does not complete the leg within a specified time or has to be towed in for repairs, it is penalized points. Then the next day all vehicles start together at the same time and place for the next leg.

All entries that can carry more than a driver are required to have at least one passenger. Due to the length of the legs, this is not a casual spectator. It may be a team member, a reporter, or simply a friend.

The tour is also a public education event. A new route is



Above: Rally cars come in all shapes, but they all carry big smiles.

Photo: Bob Wheeler

chosen each year to expose a different group of people to the cars. At the end of each leg, the cars gather in a display area, with a local committee promoting the event to the public.

### Support System & Data Gathering

An extensive event like a tour requires substantial planning and infrastructure. The field of the NESEA Tour is limited to fifty entries, since that is the maximum number which can be charged.

NESEA works with the utilities along the route to provide charging through a special trailer wired for three-phase 208 volts at 600 amps input. Each charging outlet on the trailer has a Watt-hour meter built in, as well as other instrumentation. The utilities use this charging trailer to gather experimental data about the effects of charging large numbers of EVs at the same time and place. They are interested in information about harmonics generated in the lines during charging and other issues.

Each car is also required to have a Watt-hour meter on board. This information is collected by the Department of Energy to determine vehicle efficiencies.

### Design Requirements

Outside of safety, charging compatibility, and legality, there are few restrictions or requirements on the entries. Conversion vehicles may not exceed the manufacturer's gross vehicle weight (GVW) unless there are modifications to compensate for the added weight and the modifications have been approved by NESEA Tour officials.

Because of the solar roots of the event, all cars (except production vehicles) are required to have at least one square foot of solar panel onboard. For most commuter cars, this wouldn't make a significant contribution to the drive system, so it is used to power accessories.

**Classes & Prizes**

The cars compete in different categories, including Production, Commuter, Hybrid, Solar Commuter, and One-Person. They are also categorized for judging by size and battery type (lead/acid or non-lead/acid).

As in rallies, most of the entries (about 45%) are conversions of small sedans and pickup trucks.

About 25% of the entries are scratch-built, about 20% are production EVs, and about 10% are two-wheelers.

Solectria and Unique Mobility drive systems dominate the Production and Hybrid classes with ac, brushless DC, and permanent magnet technology. However, the Commuter class is dominated by Advanced DC series motors and Curtis/PMC controllers. Ni-Cds and a few other exotic batteries show up in the Production and Hybrid categories, but the Commuter cars are running mostly Trojan lead/acid batteries. Although system voltages up to 600 Volts are allowed, most of the commuter entries are no higher than 144 Volts.

There are several types of prizes as well. Best Performance is based on Tour Miles. This includes actual miles driven, penalties for rule infractions, and extra points earned by driving bonus miles or competing in tests for acceleration, braking, hill climbing, practicality, and other criteria.

Range is judged on greatest distance in a single day on a single charge. The NESEA Energy Challenge honors the vehicles that use the least energy to travel down the road, measured in the equivalents of mpg. The efficiency award is based on miles/kwh.

**Lovely Day For A Drive**

Tours and rallies are at the opposite end of the spectrum from drag racers and land speed record trials. They are

**TYPICAL SPECS**

	<i>Rally Car</i>	<i>Tour Car</i>
<i>Car Type</i>	Stock	Stock
<i>Design Constraints</i>	Street Legal	Min. 1 sq. ft. solar panel Weight limited to original GVW*
<i>Weight</i>	2,500 - 3,500 lbs.	2,500 - 3,500 lbs.
<i>Voltage</i>	96 - 144 Volts	96 - 144 Volts
<i>Racing Speed</i>	40 mph average (25 - 55 mph)	40 mph average (25 - 55 mph)
<i>Course Type</i>	Street	Street
<i>Course Length</i>	4 - 6 miles	300 miles
<i>Start Type</i>	Standing	Standing
<i>Duration</i>	Enduro (2 - 4 hrs.)	Enduro (5 days)
<i>Field Size on Course</i>	10 to 20	25 (50 max. all classes)
<i>Winning Criteria</i>	Distance	Distance, efficiency, and various performance criteria
<i>Sanctioning Body(ies)</i>	Electric Auto Association, EV clubs, & RE organizations	Northeast Sustainable Energy Association

\* Except with compensating modifications & NESEA approval

not about speed at all. However, they are the oldest EV competitions and reflect the way the cars are actually used in daily life.

Best of all, anyone can play.

**Access**

Author: Shari Prange, Electro Automotive, PO Box 1113, Felton, CA 95018 • 408-429-1989



**WE WROTE THE BOOK ON  
ELECTRIC CAR CONVERSIONS**

**CONVERT IT** How-To Manual  
by Michael Brown with Shari Prange

Expanded & Updated 3rd Edition  
\$30.00 tax & postage included

"We built Mr. Brown's car,  
and we won." Bruce Burk,  
St. Johnsbury Academy,  
1991 American Tour de Sol  
Open Class Winner.



**ELECTRO AUTOMOTIVE  
POB 1113-HP, FELTON, CA 95018**

# Solar Pathfinder



- \* Easy to Use
- \* Fast & Accurate
- \* Diagrams from 0-66° N & 0-49° S
- \* Pathfinder with metal case & tripod  
**\$216 (Handheld \$139)**

**! New Address & Phone/Fax !**

RR 1, Box 286  
Gary, SD 57237  
Phone & Fax: 605-272-5353



**Tired of high utility bills?  
Let the SUN "COOL" your home!**

## SOLAR EVAPORATIVE COOLER

- No batteries needed
- Distributes 1,000 to 4,500 CFM
- Great for city use - don't pay local utility
- Operates on direct current from solar panel(s)

SEVERAL MODELS AVAILABLE - Call for info

## FREE CATALOG

*A Premier Manufacturer of Quality Solar Products*  
**SUNAMP POWER COMPANY**



7825 E. Evans Rd., Ste. 400  
Scottsdale, Arizona 85260

**1-800-677-6527**



Solar-Powered since 1982

# SOLAR • HYDRO

Your Connection to Renewable Energy  
in Northeast California



CA Lic. 681552

**RELIABLE:**

DC power and  
120 / 240 Volts AC

**POWER FOR:** Home, RV

Water Pumping, Cabin, Communications

**SITE SURVEY, SYSTEM DESIGN, INSTALLATION**

**916-284-7849**

4291 Nelson St. Taylorsville CA 95983



# Liberation from Cellular Madness

with an OptaPhone  
rural wireless telephone.

**Special Offer: save \$500-\$600**

**(707) 923-4506**



## Danby®

"Good things come in small packages"

- 7.8 cu. ft. Capacity Refrigerator.
- Reversible Door Hinges.
- Door Liner has large, functional divisions, plus a molded Egg Rack.
- Tall Upper Shelf accommodates 1 & 2 gal Jugs.
- 3 Easy-glide Shelves and a Large Crisper.
- Battery Powered Refrigerator Light.
- Automatic Lighter (piezo-electric)
- Automatic Safety Valve.
- European Style Door with Recessed Handles.
- Refrigerator is AGA & CGA Approved.
- **No Electricity Needed.**

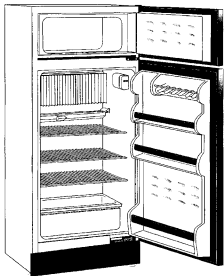

**Propane Refrigerator  
DPR2260**

**\$995.00**

Plus Shipping

(800) GO-SOLAR (467-6527) nrgoufit@cdsnet.net  
136 S. Redwood Hwy, POB 1888, Cave Junction, OR 97523  
Web Page: <http://www.energyoutfitters.com>

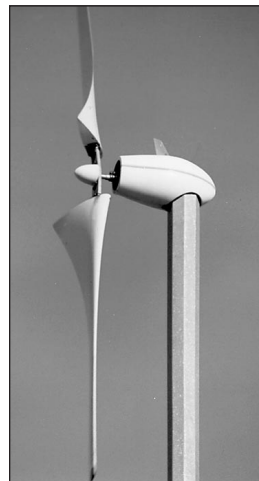

## Wind Turbines For Sale Reconditioned Carter 25 KW

- ✓ Currently Producing 40-60,000 kwh/yr
- ✓ Simple Installations
- ✓ Guyed towers raised and lowered with pickup (2 people - 10 minutes)
- ✓ Maintenance performed safely on ground
- ✓ Additional inventory parts
- ✓ Training available
- ✓ Requires 30 kw induction generator connected to utility grid

To request information packet...Contact

Windland, Inc.  
(208) 377-7777

# EV TechTalk



Mike Brown

©1997 Mike Brown

## “What brand of tires should I use on my newly converted VW Rabbit?”

First of all, the tires on a EV must be radial tires. The old fashioned bias-ply tires are not suitable for EV applications. In the radial tire world, Goodyear brought out the Invicta GLR and GFE tires to help a Japanese auto manufacturer with their Corporate Average Fuel Efficiency (CAFE) ratings. These tires were introduced to us at the first SERA 500 race in Phoenix, and we put a set on one of our Voltsrabbits.

We got impressive results. These results were not just seat of the pants impressions, but direct comparisons between two identical Voltsrabbits, one with the Goodyears and one with some Brand X radials. Starting with the same battery pack voltage and run on a identical route for the same distance, the Goodyear car came back with a noticeably higher reading on its state of charge meter. The Goodyear tire also gave better handling in both wet and dry conditions.

In more recent times, Michelin has brought out their MX4 “Green” tire. While I have no direct comparisons, a Porsche 914 we had here for a while had the Michelins on it. Handling and coast down distances were similar to what we had come to expect from the Voltsrabbit with Goodyears.

As to which tire to pick, the first step is to see if either or both Michelin or Goodyear has the tire in the size that fits your car. The low rolling resistance tires are not made in all sizes.



In the event Michelin or Goodyear doesn't have a low rolling resistance tire in your size, or you want to see if there are any other alternatives, your next stop is your library. Consumer Reports magazine tests and rates tires periodically, and rolling resistance is one of the ratings listed. The February 1997 issue has the latest tests. Armed with the test results, and having arrived at some choices, it's time to go back to the tire store in search of the right size for your car.

If you still can't find your size among the tires tested in the magazine, you're down to picking tires in your size off the shelf and reading the ratings printed on the sidewall of the tire itself. According to my tire guy, the two to look at are the Temperature rating and the Tread Wear rating. The Temperature rating should be A, which is the coolest rating. This means lowest internal friction; thus, lower rolling resistance. The Tread Wear rating should be in 250 to 300 range, indicating a harder tread compound and lower rolling resistance.

Picking the best tire in your size using these ratings should get you a good low rolling resistance tire for your EV.

The emphasis on using the size of tire that your car came with contradicts the old conventional wisdom of using the tallest, skinniest tire you can fit in the wheelwells. I feel that approach compromises the handling and steering of the car, and makes proper wheel alignment difficult.

For a more detailed explanation of EV tire selection, see *Home Power* #46.

### An Appeal to Readers

Let's expand both of our fields of knowledge. Send me more technical questions so I can find the answers for you, and we'll both learn.

### Access

Author: Mike Brown's TechTalk, Electro Automotive,  
PO Box 1113, Felton, CA 95018.  
Phone: 408-429-1989 • Fax: 408-429-1907



**MAPLE STATE BATTERY**  
**Lowest Prices — Delivered Anywhere**  
**Panels · Controllers · Inverters**  
**Servel & Sun Frost Refrigeration**

Jesus said, "I am the way, the truth  
and the life..." John 14:6

**Trojan** (802) 467-3662  
Sutton, Vermont 05867



## Inverters 1-800-245-1827

- 12V to 115v Inverter - 140w-200w peak @ \$49.50
- 12V to 115v Inverter - 300w-500w peak @ \$78.50
- 12V to 115v Inverter - 600w-1000w peak @ \$195.00
- 12V to 115v Inverter - 1500w-3000w peak @ \$440.00
- 115v Emergency Switchover Unit at 10 amps @ \$44.50
- 115v Emergency Switchover Unit at 20 amps @ \$56.00
- 12-24V Battery Isolator - 75 amps @ \$32.50
- 12-24V Battery Isolator - 125 amps @ \$44.50
- 12V Pumps 450 gph @ \$16.50 to 2500 gph @ \$72.00
- Computers Assembled to your spec. & Parts

A.C.I. PO Box 10463, Santa Ana, CA 92711

Shipping at UPS Rates

## Johnson Electric Ltd.

COLORADO LICENSED ELECTRICAL CONTRACTOR #895

Tel: 970•249•0840 Fax: 970•249•1248

Hybrid PV & Wind Remote Electrical Power Systems  
Code Approved Installations by Licensed Electricians

Remote Homes • Telecommunications • Water Pumping  
Community Water Systems • Lightning / Surge Protection

System Design • Equipment Sales • Trouble Shooting  
Turn-Key Installations • Pre Assembled Systems

2210 Industrial Dr., PO Box 673, Montrose, CO 81402

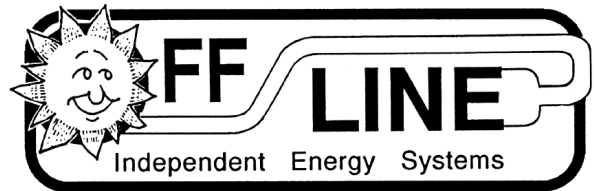

CA Lic. #661052

*Our Thirtieth Year Offgrid!*

**We will meet or beat any other company's prices.  
We provide excellent service and technical support.**

Residential Power • Water Systems • Phones • All Major Brands  
Wind • PV • Hydro • Custom Design • Installation • Mail Order

NEXT WORKSHOP—SEE HAPPENINGS

Call for information  
**(209) 877-7080**

e-mail: ofln@aol.com

located in the central Sierra, near Yosemite

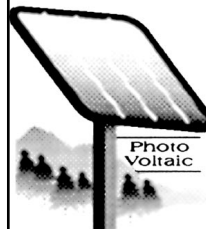

**OFFLINE**  
P.O. Box 231  
North Fork, CA  
93643



We'll Send You Our  
**CATALOG**  
for  
**\$3**

## ELECTRATHON IS HERE!

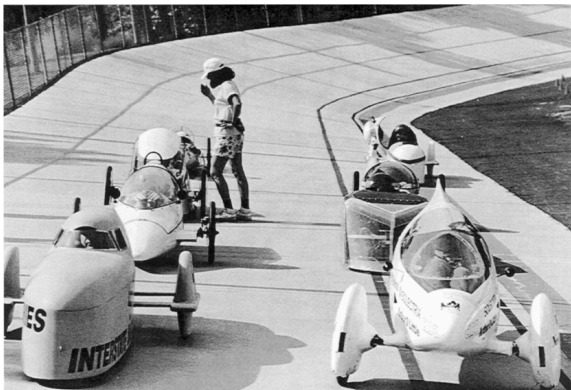

Electrathon is a fun and challenging form of race/rally competition combining vehicle design and construction skills with driving strategy. The rules allow for a great degree of design variation, but stress safety and low cost components. Battery and driver weight is regulated to ensure close and equitable competition.

- Build and drive your own electric vehicle in distance rallies.
- Learn about lightweight vehicle design and construction.
- Explore the cutting edge of alternative transportation.

### Join The Fun!

Electrathon America  
1251 W. Sepulveda Blvd., Suite 142  
Torrance, CA 90502



The official sanctioning body for Electrathon rally events

## SOLAR INDUSTRIES JOURNAL

camera ready, b/w

3.5 wide  
4.85 high



# Off Grid Pioneers

Robert Costello

©1997 Robert Costello

I am shaken from dream land by the musical beeping of the Radio Shack LED alarm clock. I stumble into the bathroom that is toasty and warm from the thermal art heater that has been on all night. I take the usual 20 minute shower with the Paloma instant hot water heater. After a quick once over the teeth and gums with the Braun electric tooth brush I am once again ready to battle the elements.

Remembering back, it's been over two and a half years since I moved onto this ten acre parcel located in the middle of Weyerhauser's 500,000 acre Mt. St. Helens tree farm. I am the only resident. P.U.D. power is five miles away. The plan was to log the old growth timber, sell the log cabin and property, and take the money and run. Then George at the local Radio Shack told me about *Home Power* magazine, written by some hippies in Oregon and how they strung water-powered alternators together to generate electricity.

I turn on my video camera surveillance monitor and scope out the driveway gate, the water intake pipe, the water filter, and the four nozzle Harris hydro at the base of the 70 foot water fall. All is well. I reposition the satellite dish to pick up ESPN 2 for a 30 minute work out with the muscle bound fitness women. I glance out the window of my hovel at the millions of 30 foot high Weyco super trees that stretch out before me. I am reminded that my struggle to survive in this wilderness is not unlike those early pioneer men and women who, like me, had a meager toe-hold on civilization and I gain strength from the knowledge that we are of kindred spirit. This mystical revelation is interrupted by the chime of my toaster oven telling me that my strawberry Pop Tarts are ready.

With my energy renewed I am prepared to take on the chores of life on the edge. I power up my IBM Aptiva and check the E-Mail. I then send a fax over the cell phone data interface. After checking the voice mail messages, I hear nothing that cannot wait. Vacuuming the rugs and Dust Busting everything else, I am then faced with the outdoor chores: clean the decks with the North Star hot pressure washer then drill and mount a Genie garage door opener. I take a break from my labors by downloading some new Duke Nukem levels from the internet with the Sky Link data demodulator. I view the midday Headline News reports of the ferocious storms that again pound the Northwest. Thousands are

without power and hundreds more huddle in Red Cross shelters. I watch all this on CNN. It is very exciting.

The sun sets early this time of year and I prepare the evening meal. I nuke a couple of potatoes in the microwave to go with the seasoned turkey breasts that have been simmering in the crock pot since morning.

Like the early settlers, having sufficient supplies on hand decides success or failure in this harsh, unforgiving land. To my dismay I find that I only have two more bottles of Boones Farm. As I finish my pioneer meal, darkness comes like a black quilt. I am startled as the outdoor solar lights flick on. I feel like the cave guys in the movie "Quest for Fire." I up the thermostat on the Hearthstone a few more turns, put the Lazy Boy on partial recline, and strategically place the hot air popcorn and the ice-cubed Coke from the Sun Frost.

With the big screen surround sound on mute I notice how, in the quietness of the forest, one can hear the smallest of nature's sounds: the rustle of the dead

leaves, the cooing of the night birds, the hum of the dishwasher. The HBO weekend movie begins as the fire light dances across the cabin floor, a scene reminiscent of the Native American lighted tepee campfires, and I am one with the land.

As the strength flows from my weary limbs I realize that I will soon fall victim to sleep. Thankfully, I have enough presence of mind to hit the record button on the remote so I will not miss the movie's ending. As if it had a mind of its own, the chair slides into full recline and the heat/massage comes on. Visions of musket-toting pioneers, buffalo-robed Indians, and lean, mean, coon-hatted mountain men dance in my head and welcome me into their brotherhood.

We off-grid folks certainly are a hardy lot. You guys want a Pop Tart?

**Access**

Author: Robert Costello, PO Box 04, Carrolls, WA 98609



**Powerhouse Paul's Stream Engines™**  
*Small Scale Water Power Equipment*

- FIRST TO MARKET:**
- Small Turgo Turbines -
  - Low Head High Flow Machines -
  - Induction Generators -
  - Brushless Alternators -

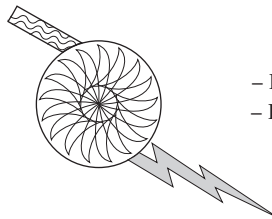

*IN BUSINESS SINCE 1980*

- operates on heads of 4 feet to over 400
- Battery voltage or high voltage for long distances
- Pelton and turgo turbines runners sold separately

**ENERGY SYSTEMS & DESIGN**

P.O. Box 1557, Sussex, N.B., Canada E0E 1P0  
506-433-3151

**Adopt a Library!**



When Karen and I were living with kerosene lamps, we went to our local public library to find out if there was a better way to light up our nights. We found nothing about small scale renewable energy.

One of the first things we did when we started publishing this magazine nine years ago was to give a subscription to our local public library.

You may want to do the same for your local public library. We'll split the cost (50/50) of the sub with you if you do. You pay \$11.25 and Home Power will pay the rest. If your public library is outside of the USA, then we'll split the sub to your location so call for rates.

Please check with your public library before sending them a sub. Some rural libraries may not have space, so check with your librarian before adopting your local public library. Sorry, private or corporate libraries are not eligible for this Adopt a Library deal—the library must give free public access. — Richard Perez

To Adopt a Library write or call

**Home Power®**

PO Box 520, Ashland, OR 97520  
1-800-707-6585 or 916-475-0830 or FAX 916-475-0941



# Restructuring & Distributed Generation

Don Loweburg

©1997 Don Loweburg

**C**entral in the transition to a competitive retail electricity market (restructuring) is the separation or “unbundling” of generation and distribution. In a restructured market, the suppliers of electrons will be in competition with one another while the distribution (wires) companies will continue as regulated monopolies. The wires or distribution system will serve a common carrier function and users (generators) will pay a fee for the use of the distribution system.

For there to be fair competition, the playing field must be level. For this reason it's mandatory that distribution companies relinquish generation. As part of the separation process, utilities are receiving handsome payments for “stranded assets”, i.e. generation facilities that they can not sell at prices that would recover their investments. These payments or “transition charges”, to

be paid by ratepayers, are justified on the grounds that utilities must protect their investors and the parent holding company, many times huge international conglomerates, from loss. Payoff, golden parachute, call it what you will, there can be no doubt that the utilities are being well protected.

Yet utilities are fighting to hold on to some generation, specifically Distributed Generation (DG). Given their already advantaged position, this is unacceptable if we are to have fair retail competition. Utilities argue that DG is not really generation. Rather, they assert, DG is a distribution tool and should remain available to them as a management asset. This argument challenges the core principle of restructuring—the separation of generation and distribution. DG by utilities will sabotage the goal of restructuring, retail competition.

The California Public Utilities Commission Office of Ratepayer Advocates (OAR) recently submitted a letter to the California Distributed Energy Resources (CADER) Collaborative. The letter, co-signed by IPP and eight other parties representing a spectrum of interests that includes consumer advocates, energy marketers, independent energy producers (large and small), and large energy consumers (retailers and manufacturers), details eight reasons that utilities (distribution carriers) should not own distributed generation. OAR's first argument for disallowing utility DG points out that if the distribution carrier could build customer sited generation rather than upgrade the distribution system itself, then a distribution bottle neck would persist and other competitive generators would be at a disadvantage. The OAR letter details other issues also involving anti-competitive and market power abuse resulting from utility DG.

DG includes many technologies. Some are renewable such as wind and PV. Those that are not renewable still represent efficiency improvements that deserve to be embraced. DG combined with efficiency measures and demand side management (DSM) will revolutionize our energy system. DG and DSM services can clearly be delivered within a competitive market structure. The monopoly franchise has no place in that competitive market. Readers who wish to more fully understand DG and why utilities can not be allowed to operate in this new and growing market should download the letter. The OAR's letter on DG is available electronically by contacting IPP.

The California Photovoltaic Association (CALPVA) is the new name adopted by the California PV collaborative, formally Photovoltaics for Utilities (PV4U). The group decided to change the name in order to reflect it's broadened mission of pursuing and developing end user markets for photovoltaics.



### Restructuring and Renewables in California

As detailed in *HP* issue #57 considerable work is being done to develop market based PV programs targeted at end users in conjunction with the renewables incentives linked to restructuring. Funding is very limited since PV is competing with other renewable technologies. Possibly as much as \$54 million over the next four years would be available. This represents 10% of the total (\$540 million) funding available for renewables. Dan Berman, co author of *Who Owns the Sun* (reviewed in this column last issue), points out that this is an insulting slight to renewables. Placed in perspective of the utility bail out (CTC), this amounts to two cents for renewables for every dollar the utilities receive!

Classified as an "Emerging Technology", an incentive program for PV with cost buy downs and low interest financing in conjunction with net metering would make PV competitive with other renewables. Net metering adds a special incentive, since the Competitive Transition Charge (CTC) can only be levied on purchased power delivered over the wires. Residential self generation is exempt. Other discussions included a possible state Solar Bank and Solar Tax Bill. These programs would require legislative approval and are being promoted by CalSeia.

Last year CALPVA designed a Simplified Net Metering Interconnection agreement. A copy of this agreement was sent to all California utilities and has been adopted by the Southern California Edison Company. We have not had a positive response from other utilities yet but CALPVA is committed to such a standard for net metered PV systems and believes it is important that such a standard be established on a national basis. IPP can provide a copy of this document electronically upon request.

### Sandia Labs Works to Simplify PV Interconnection

John Stevens at Sandia Labs chairs a group working on the technical issues of small PV systems and utility interconnection. He writes in the latest Sandia Quarterly on Photovoltaics, "Sandia is currently chairing an effort to revise the IEEE standard for utility interconnection of photovoltaic systems. Currently, both utility engineers and photovoltaic system designers have no truly satisfactory standard that treats this interconnection. An accepted standard prescribing the needs of the interconnection in clear terms is needed so that a designer could know a system meeting this standard will be accepted by most utilities, and the utility engineer will know that a system meeting the standard will be compatible with his utility."

"This effort was begun by surveying a few dozen utilities to determine what their existing interconnection

standards include in order to establish where the utility concerns are. The greatest variety of requirements are aimed at protection against islanding. If the revised standard can be written in such a way that utility concerns regarding islanding are mitigated, then many of the existing interconnection requirements can be eased. Today's inverter manufacturers have islanding mitigation schemes designed into their inverters, but it is difficult for them to present evidence to the utility that the scheme will perform as it should and that it will continue to do so for many years. What is needed is a test standard to which the islanding scheme (as well as any other protective functions) can be tested, both for performance and to assure that the scheme is fail-safe. Underwriters Laboratories has agreed to work with the IEEE working group to establish a UL test procedure that will include tests for the utility required protection functions, including islanding. This UL procedure will also test for the fail-safe operation. That is, if the protection circuitry fails, the inverter will shut down".

In discussing interconnection issues John makes two important points in conversations with me. So far utilities tend to treat PV systems (erroneously) as though they were a 500 kw rotating machine based cogenerator. Secondly, a single standard specific for PV needs to be established so that the wasted time and grief of individual efforts is avoided. CALPVA's model interconnection agreement makes specific reference to both IEEE standards and UL listing of inverters, so we are getting closer to that goal.

### SMUD PV Pioneer Program Expands

Sacramento Municipal Utility District (SMUD) located in California's Central Valley has installed over 5 megawatts of PV including over 400 customer sited rooftop PV systems. Sacramento citizens, the SMUD Board of Directors, and SMUD employees all should be congratulated for what is the most successful program of this kind in the country. This serves as an example of what citizen control of energy systems can do. Nationally two out of three people want renewable energy. Decentralized systems managed by boards accountable to the local citizens would be responsive to these desires. Recall that the citizens of Sacramento also elected to shut down their own ailing nuclear plant (Rancho Seco) several years ago. They bit the bullet and paid the cost, unlike the whining IOUs that are currently demanding usurious CTC (Competitive Transition Charge) from ratepayers to cover management's and investor's poor business choices.

At the last CALPVA meeting Don Osborn detailed SMUD's future PV program. As outlined, the four year program would place up to 10 megawatts of new PV into service. Not only does the program commit to

## Independent Power Providers

progressively reduce system cost from year to year, it also includes commitments from a PV module manufacturer and an inverter manufacturer to locate production plants in the Sacramento area. SMUD also plans to form partnerships with other Muni and Coops in order to further drive costs down. Customers may also be able to purchase systems. For purchasers in California, the incentives mentioned earlier could be available.

### Marketing Green Power

As part of California's restructuring, direct access will allow customer choice in purchasing electricity. Direct access will be phased in according to customer type with large industrial customers beginning next year and most residential customers being the last to have choice in 2002. However, if a residential customer chooses an energy supplier that provides over 50% renewable based energy, the customer will be able to switch next year. Clean Power Works of Santa Cruz, California will offer renewable based electricity in 1998. "Electricity will be delivered through the grid the way it is now," explains John Schaefer, president of the start up company, "but it will be clean, sustainable electricity from independent producers using wind, biomass, geothermal, land fill gas, and solar resources." David Katz, marketing director, says that the company has begun signing up customers. See Access

These are exciting times for renewables. For the first time in years real opportunities in the mass, grid market are beginning to appear. IPP companies, many rooted historically in the offgrid, can expect to grow into the many grid connected markets. Some opportunities are, power quality, power backup, renewable energy marketing, distributed generation, energy conservation services and system maintenance. With the cost of line extensions continuing to go up, the offgrid market also continues to accelerate. Recreation (houseboats, RVs), communications, remote residential and industrial are all growing markets.

IPP invites new company membership. Thanks to the vision and talent of Ben Root (HP staff) the IPP logo used for this column is available to members. We invite you to display it in your advertising both in Home Power and elsewhere. IPP also invites general membership, renewable energy users and advocates. We take a clear position that supports policies empowering a competitive, decentralized, renewable energy infrastructure. This best supports us and the planet.

Readers, please write or E-mail any information that you might have pertaining to issues covered or that you want covered.

### Access

Author: Don Loweburg, IPP, PO Box 231, North Fork, CA 93643 • voice/fax: 209-841-7001  
Internet email: i2p@aol.com

Sandia Labs (PV interconnection specification) John Stevens- jwsteve@sandia.gov • 505-844-7717

Clean Power Works of Santa Cruz, John Schaefer jcschaefer@igc.org • 408-471-9337 and David Katz 707-923-2277

SMUD: Dave Collier 916-732-5952



## MicroHydro Specialists

14+ yrs. living with MicroHydro

### Makers of "Lil Otto" Hydroelectric Systems

"He's a hard worker who doesn't drink very much!"

Lil Otto is a permanent magnet hydroelectric generator. He works with as little as 1.2 GPM or Heads as low as 20 feet. 12 or 24 VDC output, up to 5 Amps. Comes complete with manual and right nozzle for your site.



**\$410. shipped free in Continental USA**

CA residents add 7.25% sales tax.

Dealer inquiries invited.

**Lil Otto Hydroworks!** Bob-O Schultze KG6MM  
POB 203, Hornbrook, CA 96044 • 916-475-3401

### The Monolithic Dome

is a super-strong, insulated, concrete building that is energy efficient and impervious to disaster. Monolithic Domes are used for homes, offices, schools, shops, churches, storages, gymnasiums, cabins, and more. For 20 years, the Monolithic Dome is tomorrow's building available today.



You can also build your own Monolithic Dome.

Call 1 (800) 608-0001 for a FREE COLOR brochure or send \$19.95 plus \$5 shipping for our 60 minute information video. PO Box 479-HP • Italy, TX 76651 • www.monolithicdome.com

AC/DC Inverters, Charge Controller



**1-888-SOLARNOW**  
Toll Free

**HORIZON INDUSTRIES**

*We Sell The Best & Service The Rest*

Mention This Ad & Receive A Free Catalog  
2120 L W Mission Rd, Escondido, CA 92029

**(760) 480-0403**

Water Pumps, DC Lights, DC Appliances

DC/Propane Refrig, Track Rack

Batteries, Cables, Switches



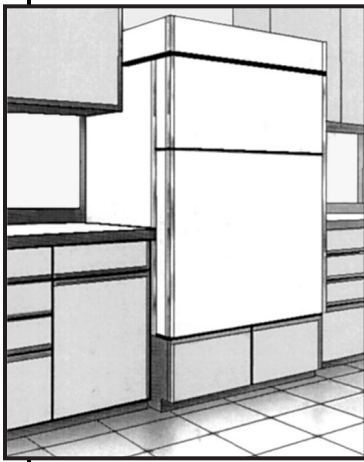

# Sun Frost

*Energy Efficient*

## REFRIGERATOR

## FREEZER

**AC models**

for cutting utility bills

**DC models**

for alternative energy

*Write or Call Now for FREE Information:*

**P.O. Box 1101 • Arcata, CA 95518-1101**

**Ph (707) 822-9095 • Fx (707) 822-6213**

<http://www.tidepool.com/sunfrost/>

SOLAR ELECTRIC INC

camera ready, b/w

3.5 wide

1.6 high

## Off The Shelf

*The spec sheet directory of renewable electricity*

300+ pages, 12 Chapters

"*Off the Shelf* is great for people seriously interested in solar photovoltaic technology who want to know the specifics of the available equipment. This product literature looseleaf is stuffed with information of current state-of-the-shelf photovoltaic system components. We recommend it to all our workshop participants." Johnny Weiss, Director, Renewable Energy Education Program. **Solar Energy International**, Carbondale CO.

"*Off the Shelf* is a must for systems designers, trainers, or those who are thinking of their own system." Paul Maycook, publisher, **PV News**.

"Overall, this is a great effort to pull together a comprehensive of manufacturers and dealers. I look forward to the next edition." Art Boyd, **MARETC, Crowder College**, MO.

"I use it almost every day." Windy Dankoff, **Dankoff Solar Products**.

"This Book is the answer for designers of renewable energy systems...just about every manufacturer in the RE industry...and an appendix listing hundreds of dealers and installers of RE products." Richard Perez, editor, **Home Power Magazine**.

**The Cost is \$69.95 including book rate postage.**

Outside U.S. inquire

### The PV Network News

2303 Cedros Circle, Sante Fe, NM 87505

Voice/fax: 505-473-1067 • e-mail: [pvpaulet@aol.com](mailto:pvpaulet@aol.com)

*Our 16th Year of PV-Powered Publishing*

**ALL PV DEALERS ARE NOT THE SAME!**

### Check us out!

- 17 years in business
- Free system design
- Full-time engineer
- Competitive pricing
- All popular brands of PV, batteries, inverters, and balance of system equipment
- Energy efficient lighting, gas room heaters, tankless water heaters, propane refrigerators, and the largest selection of alternative energy books
- For our brand new 1996-97, 140 page, design guide & catalog, send \$5 (\$8 outside US) or call our toll-free number. Credit cards OK.

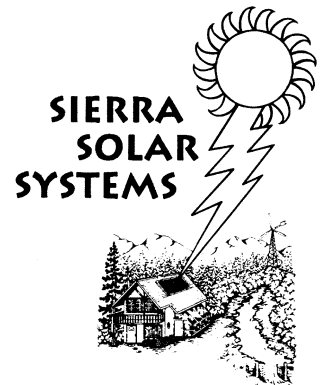

### Sierra Solar Systems

109H Argall Way, Nevada City, CA 95959

Phone: 800-51-SOLAR Fax: 916-265-6151

e-mail: [solarjon@netshel.net](mailto:solarjon@netshel.net)

internet: [www.sierrasolar.com](http://www.sierrasolar.com)

**AIM YOUR  
PHOTOVOLTAIC  
PANELS AT THE SUN...  
ALL DAY, EVERY DAY**



**American SunCo**

FREE

Information package on

**Sun Tracker 8**

PV Tracking System

- Provides 40% more power
- Accurate even in wind/cold
- Reliable
- Affordable
- Warranteed

**American SunCo**

PO Box 789H, Blue Hill, ME 04614

**(207) 374-5700**

## ***If It Happened To Me, It Can Happen to You!***

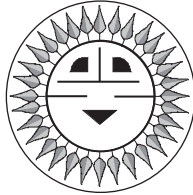

John Wiles

Sponsored By The Photovoltaic Systems Assistance Center,  
Sandia National Laboratories

**I**t all started last year when I received a call from Chris Cameron, Manager of the Photovoltaic Systems Application Department at Sandia National Laboratories. He was having some rewiring done on his house, and the electrician had installed a multiwire branch circuit (two branch circuits sharing a common neutral). Chris, being the sharp person that he is, immediately thought about the hundreds of thousands of stand-alone PV systems in the US with single 120-volt inverters that might be hazardous with this type of wiring.

He called me and I distributed the warning through letters, faxes, and Home Power magazine (see Code Corner in HP 54). Last week, I was doing some rewiring on my house, and guess what. I found seven multiwire branch circuits! All were being driven by a single Trace 4024 inverter with a 30+ amp output that could easily overload those number 14 and 12 AWG neutral conductors! If my house has them, your house may too.

These multiwire branch circuits are wired with three-conductor-with-ground cables which have a black conductor, a red conductor, a white conductor, and a bare conductor contained in a single jacket and connected to two 15 or 20-amp circuit breakers. Removing the cover panel of the ac load center (after the power has been turned off—caution: the main breaker(s) will still be hot) will easily reveal the existence of these circuits. They should not be confused with the larger conductor (8 AWG and up) 120/240-volt range or dryer circuits which typically are connected to a common, ganged circuit breaker at 40 amps and above.

When these multiwire branch circuits are operated from the grid or from a 120/240-volt inverter system, they are completely safe and comply with the National Electrical Code (NEC). When they are operated from a single 120-volt inverter rated at more than 1800 watts, they can pose a safety hazard and do violate provisions of the NEC. Inverters rated above 1800 watts can overload the number 14 AWG white neutral conductor in these circuits. The 15-amp circuit breakers used to protect these circuits will not even trip. If the multiwire branch circuit is wired with 12 AWG conductors and protected with 20-amp circuit breakers, then inverters rated at 2400 watts or more can overload the white neutral conductor, and again the circuit breakers can provide no protection. Generator feed-through with many stand-alone inverters can be at current levels significantly higher than the rated ac output of the inverter, alone. Trace 4000 and 5500 watt sinewave inverter users—take note!

There are a couple of solutions that can be employed if these multiwire branch circuits are found. One of the hot conductors (red or black) can be disconnected from its circuit breaker and the load outlets. A new two-conductor-with-ground cable can then be installed to replace this conductor. By disconnecting one of the two hot conductors in the multi-wire branch circuit cable, overloading the neutral is avoided. Such rewiring is difficult to accomplish in an existing home and would have to be accomplished by an electrician with a permit issued. Each multiwire branch circuit would have to be rewired in this manner.

A second method is to use only one circuit breaker by disconnecting one of the hot conductors from its circuit breaker (for example, the red wire) and connect it to the circuit breaker for the black conductor. This should be done only by an electrician who must determine that the circuit breaker is listed to accept two wires. If the circuit breaker is listed for only one conductor, then the red and black conductors can be spliced to a third conductor and this third, single conductor can be connected to the circuit breaker. While this method protects the neutral conductor from overloads, it may violate provisions of the NEC that limit the number of receptacles on each branch circuit. The single circuit breaker protecting two circuits also means that the total current that can be drawn from both circuits is limited by the rating of the circuit breaker—a fact that may restrict the simultaneous use of both circuits at their full rating.

If you are a renewable energy user and have a single 120-volt inverter powering your house, get out there and check for multiwire branch circuits now! Fixing them may save your home, your life, and the life of your family.

### System Longevity and Safety

PV modules will produce energy for 20 or more years. The system (called balance of system or BOS) connected to these PV modules must be designed and installed so that it too will safely and reliably handle that energy for the next 20+ years.

An interrelated group of industries, codes and standards, and regulating agencies have, for the last 100 years, been working together to ensure that electrical power systems in the United States are the safest and most cost effective in the world. These organizations include the National Fire Protection Association (publisher of the National Electrical Code), the Insulated Cable Engineers Association, the International Electrical Inspectors Association, the Institute of Electrical and Electronic Engineers, other standards organizations like ANSI and ASTM, and the manufacturers of electrical cables and equipment.

Standards are written for the equipment. The equipment is built and tested to the standards. The equipment is installed in a manner that meets the applicable codes and is then inspected to ensure that the overall system is safe.

In this and subsequent Code Corners columns, we will discuss the details of how various components in the PV system can be selected to meet the codes and achieve reliability and safety.

### Conductors, Cables, and Wires

These terms are used interchangeably, but not always correctly. A conductor may be either bare with no insulation or insulated when it is covered with electrical insulation. The material of the conductors is normally copper although aluminum may be used in limited applications. A cable can have a single conductor or can have multiple conductors. There may or may not be an outside sheath covering a multiple-conductor cable. Not all conductors of a multi-conductor cable have to be insulated and, frequently, one conductor (the equipment grounding conductor) is not insulated. Unsheathed multi-conductor cables used as service entrance cables use an uninsulated neutral conductor in most installations.

All cables that may be used in electrical power systems are described in the NEC and are tested and listed by an approved testing laboratory to standards that are published by Underwriters Laboratories. Cables that are not described in the NEC are not allowed in NEC compliant electrical systems. Cables are described by the size of the conductor or conductors and by the type of insulation.

Conductors that are commonly used in PV installations are classified in two categories. The first are conductors

that are used in fixed (non-moving) installations and are discussed in Chapter 3 (Articles 300-365) of the NEC. Table 310-13 identifies all of the acceptable cables. These cables are generally rather stiff with from one to 13 or so strands of copper wire making up each conductor, but they may be obtained on special order with a high number of strands that makes them more flexible and easier to install.

In installations where there is significant movement such as PV trackers, conductors known as flexible cords and cables may be used. These cables are covered by Article 400 in the NEC and Table 400-4 identifies them. These Article 400 flexible cords and cables may not be used in fixed installations where there is no movement, but there are a few exceptions to this rule. For example, flexible cables may be used as inter-cell battery cables where stiff cables might deform battery cells.

Conductors come with numerous and differing insulations. The type and thickness of the insulation determines the temperature and moisture rating of the conductor and how it can be installed—in free air, in conduit, direct buried, etc. The temperature and moisture ratings of the insulation along with the conductor size are used to determine the ampacity or current-carrying capacity of the cable in various installations.

In most residential and commercial electrical power systems, conductors are required to be installed as part of a multi-conductor sheathed cable assembly (such as type NM non-metallic sheathed cable a.k.a. Romex®) or in a conduit or other raceway—either metal or nonmetallic. Single-conductor cables are not permitted, either exposed or installed inside walls. The wiring between PV modules is an exception.

### PV Module Wiring

Because PV modules operate at high temperatures and are installed in exposed locations, the cables used to connect them require special attention. Some PV modules have separate positive and negative junction boxes, one at each end of the module. With these types of modules, the NEC allows exposed single-conductor cables to be used for module-to-module connections. The cable must be insulated properly for the exposed, outdoor conditions. This generally means that it must be rated for high temperatures (90°C insulation is required), wet-rated (it does rain), sunlight resistant (part of the UL Listing information), and otherwise suitable for the environment. Cable types that meet all of these requirements (although not marked as such) are USE-2 (Underground Service Entrance), UF (Underground Feeder where marked sunlight resistant), and SE (Service Entrance). Both USE and SE are

tested and listed as sunlight resistant although they are not so marked. Single-conductor UF cable is acceptable when marked sunlight resistant because it has a 90°C insulation.

If the PV array is accessible to the general public (children of all ages), then consideration should be given to placing all wiring in conduit for maximum wiring and public protection. Local codes generally require that all wiring in commercial and multifamily dwelling installations be placed in conduit.

Other wiring methods that are generally acceptable for any electrical wiring, including multiple conductor sheathed cables and conductors in conduit may be used to connect PV modules. The use of UF cable as a multiple-conductor sheathed cable for PV module interconnections should be avoided because it is rated as a 60°C cable, which is not useable on PV modules that require 90°C cables.

PV modules are installed in exposed locations (NEC definition) and, when conduit is used, the cables installed in the conduit must be wet-rated and rated for high temperatures. Single conductors, that are intended for use in conduit, meeting these requirements include types THWN-2, RHW-2, and XHHW-2. The "T" in these type ratings refers to a thermoplastic insulation. The "R" represents a rubber insulation, and the "X" represents a cross-linked synthetic rubber. The letter "H" represents a high-temperature (75°C) insulation under dry conditions, and "HH" represents a higher temperature (90°C) insulation. The "W" represents an insulation rated for wet areas. The "N" represents a nylon jacket. The "-2" designation represents an insulation that is rated for both high temperatures (90°C) and wet locations.

Many commonly available cables have multiple markings such as THHN/THWN-2 or USE-2/RHW-2/XHHW-2. This allows a single cable to be used throughout an installation without having to splice two different cables together as the installation method varies. After the wiring from the PV array has left the immediate vicinity of the PV modules, the single-conductor exposed cables are no longer allowed and one of the NEC Chapter 3 wiring methods must be used. This transition, where exposed cable has been used, usually takes place in a junction box fastened to the array mounting frame. The transition is required to provide greater degrees of physical and fire protection for wiring run inside a building. Even the exposed, single-conductor cables used for PV module connections should be fastened securely to the module and array frames for physical protection.

### Inside Wiring

The wiring for a PV system, both ac and DC, that is installed away from the PV array must conform to the standard electrical wiring practices used throughout the country for ac wiring. These numerous wiring methods are described in Chapter 3 of the NEC and differ between residential and commercial installations. Since batteries are usually fixed installations mounted inside a structure, the wiring to and from the battery bank must also comply with the Chapter 3 NEC requirements.

### Battery Wiring

Nearly all cables and wiring methods listed in Chapter 3 are suitable for batteries. These conductors will usually be larger in size than other conductors in the system, because the currents that they are required to handle will be higher. The use of metal conduits and metal-sheathed cables near batteries should be avoided due to the potential for corrosion and short circuits.

Inside battery enclosures, single-conductor cables may be used for battery interconnects, but outside the enclosure, a standard wiring method must be used. Welding cables and automotive battery cables are not acceptable cables for meeting NEC requirements unless they have been permanently attached to the battery cells by the battery manufacturer.

Battery cables in the battery enclosure are typically THWN, RHW, or USE type cables. In the smaller sizes (up to about number 1 AWG), standard building wire with 7-13 strands of copper is generally used. In the larger sizes (1/0 AWG and up), flexible, multiple stranded (400+ strands) cables of the USE or RHW type are used. These cables are suitable for use in the battery enclosure and then in conduits between the battery enclosure and the power center or inverter.

### Where to Buy

Most types of cables are available from local electrical supply stores and building supply stores like Home Depot. Some of the more specialized cables like number 10 AWG stranded USE cable used for module wiring and the extra-flexible USE/RHW cables used for battery-to-inverter connections are available from the larger PV distributors and dealers that advertise in *Home Power Magazine*.

In the next Code Corner Column, the correct sizing of the various cables in a renewable energy system will be covered. The missing fuse and the diode may also be addressed.

### Questions or Comments?

If you have questions about the NEC or the implementation of PV systems following the requirements of the NEC, feel free to call, fax, or write

me at the location below. Sandia National Laboratories sponsors my activities in this area as a support function to the PV Industry. This work was supported by the United States Department of Energy under Contract DE-AC04-94AL8500. Sandia is a multiprogram laboratory operated by Sandia Corporation, a Lockheed Martin Company, for the United States Department of Energy.

#### Access

Author: John C. Wiles, Southwest Technology Development Institute, New Mexico State University, Box 30,001/ MSC 3 SOLAR, Las Cruces, NM 88003 505-646-6105 • FAX 505-646-3841

National Electrical Code ® and NEC ® are registered trademarks of the National Fire Protection Association. The 1996 NEC and the NEC Handbook are available from the NFPA, 1 Batterymarch Park, Quincy, MA 02269-9101 • 800-344-3555 • 617-770-3000.



# SUNPOWER CO.

**ELECTRICITY From**

- Sun
- Wind
- Water



800-946-9501

Featuring products by:



**SIEMENS**  
Solar Industries

Visit our solar & wind-powered showroom at Junction of #7 & #37 just North of Tweed R.R. 3, Tweed, Ontario, Canada KOK 3J0

Fax & Phone:  
**(613) 478-5555**

Web:  
[www.Mazinaw.on.ca/sunpower.html](http://www.Mazinaw.on.ca/sunpower.html)

E-Mail:  
[Sunpower@bvl.igs.net](mailto:Sunpower@bvl.igs.net)

## American Wind Energy Association



AUSTIN, TEXAS

Technological advances  
Hybrid and small system projects  
International markets  
Wind resource assessment  
Environmental compatibility  
Legislative and regulatory issues  
Electric industry restructuring  
Green marketing  
Financing and economic perspectives  
Wind farm operations

Phone (202)383-2500 Fax (202)383-2505 E-mail <lindaredmond@mcimail.com>

**June 15-18, 1997 Austin, Texas, USA**

### CHINESE DIESEL ELECTRIC POWER

**WHEN AND WHERE YOU NEED IT!!!**

In many instances cheaper per watt than your electric monopoly.

#### Generator Sets from \$2250

Parts in stock for most Chinese Diesel Engines

**Danby®**

Danby Propane Refrigerators

**STATPOWER**  
TECHNOLOGIES CORP.

Stat Power Inverters

CHINA FARM MACHINERY

Tel. (909) 657-0379

Fax (909) 657-8120

### GEO SOLAR TRACKER

- SUPERB DESIGN
- CLEAN & STURDY
- BEST MATERIAL
- EASY TO ADJUST



• COST \$695

- 10-20 PANELS
- HEIGHT ADJUSTABLE
- AUTO & MANUAL
- COMPLETE KIT
- EASY TO ERECT
- CALL 7-8 AM or 1-2 PM

**707 984-8122**

BOX 652 WILLITS CA 95490

# THE FUTURE OF LOW COST SOLAR POWER

## *The Midway Labs' PowerSource Concentrator Module*

- Two-stage optical concentration—over **THREE HUNDRED SUNS!**
- From 2 Module 230 watt up to 12 Module 1380 watt
- Electrically tracks the sun without any adjustment, year in and year out.
- **TEN** year warranty
- Array automatically repositions to the East after sundown!
- Withstands over 100 mph windloading!
- Made in the USA
- New Wattsun™ Azimuth trackers now available



12 Module Array  
Tempe, Arizona

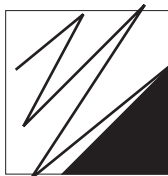

**We've  
Moved!**

MIDWAY LABS, INC., 350 N. Ogden, Chicago, IL 60607 USA

Paul Collard or Bob Hoffmann 312-432-1796 (7863), FAX 312-432-1797

Check our home page at <http://www.megsinet.com/midway/>



## **Back Issues of Home Power !**

Check out HP#59...

It contains an index of all articles back to issue #1.

You can buy back issues individually:

- \$3.25 each for #11, #13, and #16 through #20
- \$4.75 each for #21 through #45 (except for #35 & #36)
- \$5.75 each for #46 through #59

Or

**Deal #1:** All 43 available issues for \$141

**Deal #2:** 6 or more issues (of #21 through #59) for \$4.00 each (*sent bound printed matter*).

*for U.S. ZIP codes only, see page 81 for international back issues.*

(Sorry, we're out of issues 1 through 10, 12, 14, 15, 35 and 36). We are planning to compile them into a CD. Until then, borrow from a friend. If you have a computer (or a friend with one) download the article you're missing by calling the Home Power bulletin board at 707-822-8640. Or check with your local library; through interlibrary loan, you can get these back issues. Jackson County Library in Oregon has all issues as does the Alfred Mann Library at Cornell Univ.)

Home Power, PO Box 520, Ashland, OR 97520 • 800-707-6585 • 916-475-0830 VISA / MC

**Good Info!  
Good Deal!**  
**800-707-6585**  
**in USA**





# Home Power's Business

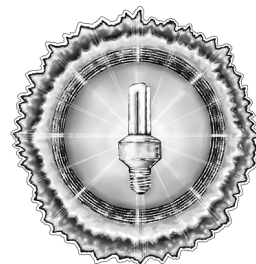

"The man who on his trade relies  
Must either bust or advertise."

Sir Thomas Lipton — 1870

## Display Advertising

### Advertising Rates per Consecutive Insertion

	Single Insertion	Three Insertions	Six Insertions	Ad Area sq. in.
Full Page	\$1,200	\$1,080	\$1,020	64.13
Half Page	\$672	\$605	\$571	32.06
Third Page	\$480	\$432	\$408	21.38
Quarter Page	\$377	\$339	\$320	16.03
Sixth Page	\$267	\$240	\$227	10.69
Eighth Page	\$214	\$193	\$182	8.02
Twelfth Page	\$150	\$135	\$128	5.34

Four process color (CMYK) in any sized advertisement for a flat rate \$185 per insertion. For inserts, and current subscriber/circulation demographics, please call us.

*Home Power* is published bi-monthly. Ad deadline for the Aug / Sept 1997 issue (HP #60) is 13 June 1997. Call 916-475-3179 for further details.

## MicroAds

MicroAd rates are 10¢ per character. Characters are letters, numbers, spaces, and punctuation marks. \$15 minimum per MicroAd insertion. Send check with your ad. We do not bill MicroAds.

## Home Power Magazine for Resale

Quantities of *Home Power Magazine* are available for resale by distributors, newsstands, bookstores, energy businesses, and others. Please call or write for rates and shipment specifics.

## First Class Home Power Subscription

*Home Power Magazine* (6 issues) via First Class U.S. Domestic Mail for \$36. Many of you have asked for faster delivery of your issues. So here it is: First Class *Home Power*. All First Class issues shipped in an envelope. We start your subscription immediately with the current issue.

## International Home Power Subscriptions

Due to the high cost of international mailing, we charge more for *Home Power* international subscriptions.

### 1 YEAR — 6 ISSUE INTERNATIONAL RATES:

#### All payments in U.S. currency ONLY!

Canada:	Air — \$36	Surface — \$30
Mexico:	Air — \$38	Surface — \$30
Western Hemisphere:	Air — \$40	Surface — \$30
Europe:	Air — \$53	Surface — \$30
Asia and Africa:	Air — \$64	Surface — \$30
Pacific Rim:	Air — \$64	Surface — \$30

Surface shipment may take up to three months to get to you. All international issues shipped in mailing envelopes. International subs are best paid for by either VISA, MasterCard, or funds from a U.S. bank.

International orders call: 916-475-0830  
or FAX: 916-475-0941

## Back Issues of Home Power Magazine

Back issues through #20 are \$3.25 each (\$4.25 each outside USA) while they last. Sorry no more issues #1-#10, #12, #14, #15, #35, or #36. Back issues of #21 through #45 are \$4.75 each (\$6 each outside USA). Back issues #46 to the present issue are \$5.75 each (\$7.25 outside USA). Back issues are shipped First Class mail in an envelope or box. See the ad index for current *Home Power* back issue specials. The text and line art from back issues #1-#37 on CD ROM (IBM & Mac) at \$29 each.

## Second Class Home Power Subscription

*Home Power* (6 issues) via Second Class U.S. Domestic Mail for \$22.50. Second Class is forwardable for one issue (2 months), so let us know immediately if you move! We start your sub with the next scheduled issue, so please allow ten weeks for your first copy to arrive.

**ACCESS** ➡ **Home Power, PO Box 520, Ashland, OR 97520 USA**

**800-707-6585 or 916-475-0830 Subscriptions and Back Issues**

**916-475-3179 Advertising and Editorial**



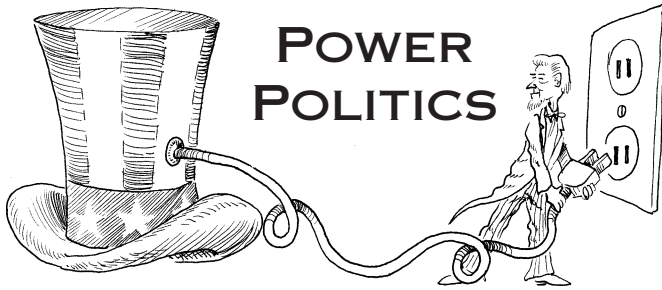

# What's a Redwood Alliance, Anyway?

Michael Welch

©1997 Michael Welch

Every year about this time I am reminded of the events that led me to begin and continue my energy activism, the Chernobyl and Three Mile Island nuclear accidents. Those famous accidents then turn my thoughts to the local nuke plant that few have heard of, the Humboldt Bay Nuclear Power Plant.

I remember the reports of the accident at TMI at about the same time I saw the controversial movie, "The China Syndrome." Not long after that I was thinking about planning a big party. I used to like to do that sort of thing for my friends, their friends, and even friends of their friends (I still work on huge fundraisers for various organizations). These parties were pretty well known for big fun and good music. I heard about Redwood Alliance, and because of TMI and the movie I changed course and offered to turn my party into a fundraiser, the first annual Valentines Dance and Mexican Dinner.

## Humboldt Bay Nuclear Power Plant

Before I knew it, these wild and caring folks at Redwood Alliance had me roped into all kinds of projects. What a great group this was. We were putting out a large quarterly newsletter and mailing it to thousands of people all over. We put a "safe energy" proposition on the City of Arcata's ballot and passed it in spite of PG&E's outspending us 25 to one trying to defeat it. Our local nuke plant was temporarily shut down and all the time we were pushing for decommissioning instead of reopening. We held news conferences to let the public know of the problems at the plant. We organized two Decommissioning Conferences at a time when most people had no idea what to do with these plants once they were shut down. These conferences had Amory and Hunter Lovins and Ralph Nader as their keynote speakers and included engineers, economists, politicians, and energy experts among their presenters. Our thing was to use education as a tool to end the reign of nuclear energy.

PG&E gave us lots of ammunition in this war. They screwed up an awful lot, not realizing that our little grassroots organization would eventually find out and use the info to our advantage. Humboldt Bay nuke plant's manager, in a leaked inside memo, said that Redwood Alliance's members are "experts at giving us a black eye." Boy did we ever make hay with that memo! But that was just the small part of it. This plant was one of the first nuke plants in the nation, and was built at a time when a gullible public was buying into the argument that nuclear power was not harmful and would be "too cheap to meter."

But reality was a different matter. More and more money was being spent on each nuclear power plant as experience dictated more and more caution, even among the strongest proponents of nuclear power.

At the same time, safety was becoming an issue locally. The plant had been built only a quarter mile away from a grade school and a small community. Because of both worker exposure and offsite leaks of radioactivity, *Science Magazine* called the Humboldt Bay Nuclear Power Plant "the dirtiest plant in the nation." We believed it. Over the years we have received lots of anecdotal evidence about cancers and lung diseases among those that had attended the elementary school and lived near the plant. One of our own had become involved because a cancer normally associated with radiation had claimed one of her lungs at an early age. Even both of California's legislatures suspected a problem there and voted to fund an epidemiological study of the inhabitants around the plant, only to have it vetoed by a governor that was in the pocket of PG&E.

### **Goliath**

Redwood Alliance was making progress in the community. But it wasn't easy. As you might imagine, working against the most powerful corporation in California and the largest investor-owned utility in the world, PG&E had a lot of influence to wield against us. Instead of the local media publishing factual articles about our events and telling the truth to the community, they took the utility's direction of trying to discredit us as commies and left-wing fringe. Fortunately, the truth prevailed.

Like everywhere else in the nation, people were beginning to believe what we and hundreds of others like us were saying, "Nuclear power sucks!" Of course, it helped a bunch when things like TMI and the "Whoops" (WPPS) nuclear bonds financial failures in Washington state threw so much adverse publicity at the nuclear power industry. It also helped when people that were involved in the antiwar movement of the sixties began to scrutinize the corporations that were profiting from the war. These folks soon realized that many of the same corporations were also involved in the nuke industry and began to look into the issue. As the antiwar battle died down a lot of public attention became focused on nuclear energy. Then the "Energy Crisis" hit.

### **Radioactive Balloons**

We continued our efforts. With the Acorn Alliance from southern Humboldt County we did balloon releases at the nuke plant with prepaid return cards attached. People could fill in the location where the balloon was found, and mail the card back to us. Hundreds of "radioactive" balloons were discovered and cards returned, many from thousands of miles away. We passed a county referendum against the transport of high level nuclear waste in the hopes that it would prevent the nuke plant from shipping its dangerously irradiated fuel rods. Unfortunately, the county District Attorney's office was unable to enforce it because of a New Jersey Federal Court ruling that denied state and local governments the right to supersede federal law with regard to nuclear waste transport.

### **We Put Our Bodies on the Line**

We also were very involved in direct action, mostly non-violent civil disobedience at Diablo Canyon. And the Redwood Alliance actually got its start when some folks decided to go across the nation in a funky converted school bus to a non-violent protest at the Seabrook nuke plant. They decided on the way back to form Redwood Alliance to work on the Humboldt Bay and Diablo Canyon nukes. We then joined with the Abalone Alliance which was an alliance of California's anti-nuclear groups. We and the AA's 64 other member

groups were not successful in stopping the opening of Diablo Canyon, but we feel pretty good about raising enough awareness in the state to ensure that there will never be another nuke plant built here. Now the AA works by itself and almost entirely on stopping the nuke waste dump which California's governor is trying to build in Ward Valley near Needles. Ward Valley is also a project that Redwood Alliance worked on, mostly in the courts and on other legal and political fronts, for several years until it became cost prohibitive, mostly because we are about 900 miles away.

### **In the Courts**

Redwood Alliance has been involved in several other courtroom and other legal proceedings in our efforts to nail the lid shut on nuclear power. We helped the California Public Utility Commission (CPUC) to determine the best way for the utilities to collect funds for the eventual, and unavoidable, decommissioning of California's nuclear power plants. We wanted collection and investment of the funds to be done in such a way that the funds would be safe, available when needed, and not reinvested in polluting technologies. We also got involved in two proceedings to make sure that enough funds would be collected for decommissioning the Diablo Canyon and Humboldt Bay plants.

This latter strategy was very interesting. The safe-energy movement wants the public to understand that it could cost as much to eventually decommission a nuke plant as it did to build it in the first place. We figure that any knowledge of the true financial costs of nuclear power would help make sure that no more plants are built. Of course, it was the nuclear industry's strategy to severely underestimate the costs of decommissioning to improve their chances for more plants in the future. Economic experts have testified that Diablo Canyon could cost \$5 billion to dismantle 20-30 years after it started up. Wow. That's a lot of money. When you consider that it cost more than \$5 billion to build, and that, according to PG&E's own documentation, they would make more than \$5 billion in capital investments over the lifetime of the plant, the total costs of the plant would reach more than \$15 billion! (Not including dealing with the high level nuclear waste for hundreds of thousands of years, and also not including this plant's portion of the hundreds of billions of dollars the government has tossed down the nuclear money hole.) If only people realized this! Unfortunately, there is so little actual experience in the area of dismantling nuke plants that it has not been difficult for the industry's high paid attorneys to get the courts to accept their severely underestimated decommissioning costs.

### **Diablo Canyon Doubles Our Utility Rates**

We also got involved in the CPUC court case over how

much the public would be charged for its new plant, Diablo Canyon. Because of extensive cost overruns and construction errors at the plant (Remember, this is the one that had the blueprints mistakenly reversed for the second reactor—a mistake that was not discovered and repaired until construction was almost complete), there was a strong case made to disallow the utility from collecting almost \$4 billion from ratepayers. The utility snowed us and other small intervenors by sending us a literal truckload of documents to answer our “discovery” questions. How could a small group like ours possibly participate against someone that can afford to spend tens of thousands of dollars just to send us documents? We tried anyway, but we and everyone else were stymied when the mega-utility hired Warren Christopher to negotiate a back-room deal between the state, themselves, and a pro-PG&E judge to implement a new concept in the CPUC called performance-based rate-making. Under this plan the utility is paid more if the plant runs more. This obliterated the past practice of basing a plant’s profits on a return on investment, much of which might have been disallowed during the hearing process. Of course, performance-based ratemaking is a bad idea for nuke plants because it gives the utility incentive to run the plant as much as possible, even when something is wrong.

**Shake and Bake**

Two other court cases that Redwood Alliance took the lead on involved the fact that the Humboldt nuke plant is built on top of an earthquake fault. That’s right, not only was the plant built and designed poorly and built near a grade school and population center, it was knowingly built in a seismically active area! When PG&E turned off the nuke for refueling in 1976, a local geologist publicized an earthquake fault near the plant. Even the pro-nuclear Nuclear Regulatory Commission wouldn’t allow them to restart the plant. But the utility did not give up easily.

They did study after study saying that there wasn’t an earthquake problem. Fortunately, the NRC did not believe them and finally the utility gave up and stated they would never reopen the plant. In the meantime, they had spent \$40 million on these studies and on bringing the plant up to the standards that the flawed studies had called for. They wanted their money back from the ratepayers and would have gotten it had Redwood Alliance not gone to court on behalf of the ratepayers asking that these monies be disallowed. Redwood Alliance saved ratepayers that full \$40 million, with the help of an honest judge.

The other earthquake/Humboldt related case was over the NRC re-licensing of the defunct plant. We originally were insisting that the high level waste be moved out of the area and the plant immediately dismantled. We were unable to maintain that position in court and finally settled on an agreement that the plant would be dismantled immediately upon removal of the high level waste and that the utility would investigate on-site dry cask storage as a safer method of storing the high level nuclear waste at the plant. Once again, the massive power of PG&E has worked to the detriment of a surrounding community. The earthquake fault in question is called the Little Salmon fault, travels directly under the nuke plant site, and is capable of a greater than an 8.0 earthquake. Geologists have discovered that it is connected with the Cascadia Subduction Zone which is where the Pacific Plate slides under the northwestern U.S. Evidence states that this earthquake fault slips every 300 to 700 years, and it has been about 300 years since it last slipped. That means it is not a matter of “if” an earthquake happens under the nuke plant, but more accurately “when.” It’s only a matter of time.

**Funky Mountain Institute Changes the World**

Then I met the Perezes. A friend knew I had a budding interest in renewable energy and introduced me to *Home Power* magazine. For years Redwood Alliance had suggested the choice of decentralized renewable energy as an answer to what should replace the nukes and fossil fuel electricity choices. But, admittedly, we knew nothing about RE other than that we wanted it. I made a pilgrimage to Home Power Towers (which I now do monthly). It was there that the Funky Mountain Institute changed my life and the course of Redwood Alliance forever. *HP* taught me “how to do it,” and when a former partner and I purchased a home, a commitment was made to not use utility power. Richard and Karen also appreciated Redwood Alliance’s background and my advocacy, and here I am.

Since then, Redwood Alliance has radically changed its course to be more of a positive advocate for renewable

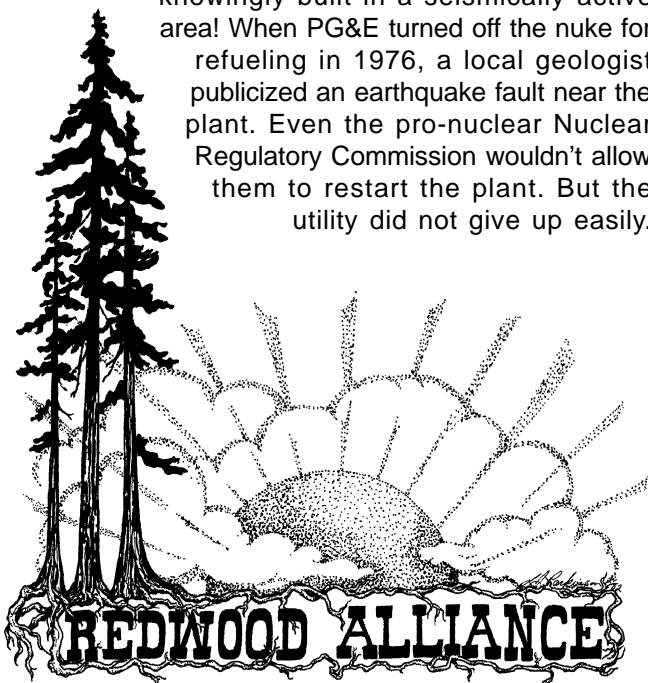

energy rather than strictly antinuclear. Now we have energy fairs, a new workshop for getting off the grid a little at a time, a computer bulletin board system for home scale RE, PV demonstration centers, and we spend a lot of time publicizing our renewable energy future.

**Where Do We Go from Here?**

Like many grass roots organizations working on RE and nuclear issues, we are in a major funding crunch. Energy is not the sexy issue it once was, causing our funding sources to slowly dry up. Redwood Alliance's very future is in question since we rely on community support to keep going at it. We have had a ton of successes over the years, and if we can keep it going will have a ton of successes in the future. If you or anyone you know can help Redwood Alliance financially, please let us know.

**Access**

Author: Michael Welch, c/o Redwood Alliance, PO Box 293, Arcata, CA 95518 • 707-822-7884  
 E-Mail: michael.welch@homepower.org  
 Web: www.igc.apc.org/redwood

Tax deductible contributions can be made to our sister organization with 501c3 tax exempt status, Redwood Environmental Education Institute.



**RENEWABLE ENERGY with the EXPERTS**

*An Instructional Video Series on the Basics of Residential Renewable Energy*

**Residential Solar Electricity with Johnny Weiss** 48 mins  
 Johnny Weiss is one of the founders and teachers at Solar Energy International in Carbondale, Colorado

**Residential Wind Power with Mick Sagrillo** 63 mins.  
 Mick Sagrillo is the *Home Power* Wind Energy Editor and has installed or repaired over 1000 wind turbines

**Residential Microhydro Power with Don Harris** 44 mins.  
 Don Harris has designed and manufactured over 1000 micro-hydro power plants.

*"The best videos on the fundamentals of renewable energy that I have ever seen."* –Richard Perez, (Reviewed in HP #56)

Now Available from:

**Scott Andrews, PO Box 3027, Sausalito, Ca 94965**

**\$39.95 each or \$100 for the set of 3 (plus \$5 S&H)**

Send check or money order (sorry, no MC or VISA)

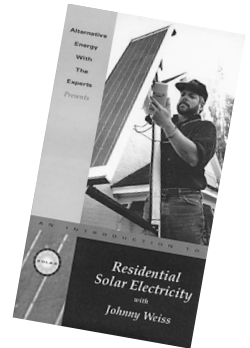

**The Midwest Renewable Energy Association**  
*Educational Institute Workshops*

*MREA is a grass-roots, non-profit educational organization whose mission is to promote renewable energy & energy efficiency through education and demonstration.*

*Membership and participation in the MREA are open and welcome to all interested individuals and organizations.*

**Pre-Energy Fair Workshops:**

*Help Install the Systems that Power the Midwest Renewable Energy Fair*

- **Off Grid Wind Systems**, Mick Sagrillo, Lake Michigan Wind & Sun, June 6–8, Amherst, WI, \$150
- **Utility Intertie Wind Systems**, Mick Sagrillo, Lake Michigan Wind & Sun, June 13–15, Amherst, WI, \$150
- **Hands-On Photovoltaic Systems**, Jim Kerbel, Photovoltaics Systems, and Chris LaForge, Great Northern Solar, June 10–13 & 16–18, Amherst, WI, \$300
- **Straw Bale Construction**, Mark Morgan, Morgan Design & Construction, and Eric Hart, Community Eco Design, June 18, Amherst, WI, \$50

**Fall workshop series begins in September**

Workshops combine classroom instruction with hands-on work for a complete learning experience. Class sizes are small, please register early.

PV class '96



Wind class '96

*For a complete schedule of our workshops, call or write:*

**The Midwest Renewable Energy Association • PO Box 249, Amherst, WI 54406**  
 phone (715) 824-5166 • fax (715) 824-5399

Home

&

Heart

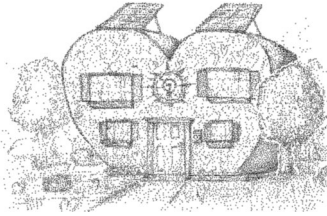

## Kathleen Jarschke-Schultze

Over the years our renewable energy system has grown to encompass solar, wind, and microhydro power. There are seasons of the year where these combined power sources exceed our regular usages. If we are producing power but not utilizing it, that is power wasted.

### The Sources

Our creek runs high enough in the winter months to provide all the power to run our system and provide for our needs. Since this is the only power source readily available to us in the winter we must conserve our usage. The creek slowly lowers its volume throughout late spring and by midsummer is too low to provide power for us.

From spring to fall we get the down slope, down canyon wind every day in our small valley. The wind fits and starts in February and becomes a regular daily occurrence by April. The breeze starts around 1:00 PM and blows until sunset. When these two power sources begin to overlap they create enough power that our conservation efforts must turn to utilization efforts.

By the end of March or the first weeks of April the sun reveals itself off and on, teasing us before easing into the full solar blast of summer that lasts well into October. With all three sources working for us we evaluate each day in terms of what we can use the extra power for and what we can get done that day.

### Conservation

It becomes second nature to check the E-meter mounted into our dining room wall while drinking our morning coffee. If the battery gauge does not read full I know we are in a conservation mode. That means laundry has to wait, no electric bread making, the one person—one light rule is in effect. Don't turn the computer printer on until you need it.

We have chosen our appliances to be efficient in their use of power so this is no real hardship. It simply changes the schedule of any household chores that involve power usage. Since we both work from our home the businesses have priority claim on the power generated daily. First work, then everything else. This is not tricky at all. We have been trained to this electrically

conservative lifestyle in the years of slowly building and honing our RE system into its present state.

### Utilization

Now comes the tricky part. When the wind blows, the creek flows and the sky glows, the time for action has come. When I get up in the morning and the batteries are full I start a load of laundry. Later in the day when the wind starts I dry that load in the dryer and start another load (there is always laundry waiting to be done). While the second load is drying I do a load of dishes in the dishwasher. Dishes can only be done every other day as I will not do a half load.

The sun is out, the wind is howling and I need to use power right now! I turn on the electric air cleaners. We have two air cleaners. One in the bedroom and one in the living room. I turn them both on high, it really helps clear the dust and woodstove ash from the air. It is most efficient to vacuum while you have the air cleaners on so that any dust you stir up can be sucked up too.

Microwaving potatoes can use up extra power. Quite a bit actually. My microwave is small, just big enough for one dinner plate. I do two batches of whole potatoes, then when they cool down I can make potato salad. Of course you could microwave small casseroles too, if you had not started one in the sun oven earlier.

Now that I have the bread machine I can make a loaf of bread to utilize some of that excess power. Not the regular, no frills loaf but the 1 1/2lb whole wheat jalapeno cheese loaf on the dark crust setting. If it is real windy and sunny, I can make two loaves.

In the summer, when the wind and sun are both happening it is an excellent time to shampoo the carpets. Since we have invested in our own rug shampooer I can choose when to do the job. I open all the windows and shampoo every carpet in the house. The wind blowing through the windows dries the carpets before nightfall. With the upholstery attachment I can do the couch too. This would happen on a weekend when our computer systems aren't up and drawing power all day.

### Heating and Cooling

We have a 900 watt electric element in the water heating tank that gets shunted on automatically when the batteries are full. However, in the summertime the Thermomax solar water heater is also making hot water to beat the band. So we need to find other places to utilize the extra power. I do have a sign up above the kitchen sink warning of high water temperature. Another caveat, always check the temperature of your shower before you step inside.

Bob-O bought me a small electric heater for my basement office. It is a 750 watt size. I can turn it on and dial its control to the point where the heater is just turning on and it will operate automatically, keeping the room at the selected temperature.

In the heat of summer we open the curtains and windows in the evening to get whatever cool breeze may happen. In the early morning we close the windows and the curtains to keep the house cool during the day. We have a small indoor, portable evaporative type cooler on wheels. You pour water into the side slot and the cooler runs a fan to spread the cool air around. There is a place where you can pour ice cubes if you want the air even cooler. We have a larger fan on a stand that has three speed settings and is directional. By running both of these we can keep the house cool until about 4:00 PM even when the outside temperature has been over 100° F outside. At that point we open the windows for the then cooler breeze.

#### Future Perfect

Now that we seem to be on top of our power consumption efficiency we are looking for a window type swamp cooler. My personal dream is to get a big freezer.

I think I want an upright model so food doesn't get lost in the depths of a chest type freezer. I figure if I put the freezer in the basement (which stays at a fairly constant temperature) it shouldn't use too much power. In the winter the basement does get downright cold, but in this case that would be good. It would use even less power in the winter when we have less power to spare.

I could just open it once a week to replenish the smaller freezer on my Sunfrost RF-16 upstairs. I keep thinking about the ease of preserving the harvest of my garden without canning. The sales on meat that I could take advantage of would make it worth it. (Yes, Bob-O and I are both omnivores.) I am pondering the model and brand selection now so any advice from experienced readers would be greatly appreciated.

#### Conclusion

The same principle of power conservation applies to power utilization. That is: use the amount of power you are producing. Timing is everything. How does that song go? "I get all the news I need from the weather report," and the E-meter.

#### Access

Kathleen Jarschke-Schultze is dreaming of a freezer to help her utilize power at her home in northern-most California, c/o Home Power Magazine, POB 520, Ashland, OR 97520 • 916-475-0830  
Email: [kathleen.jarschke-schultze@homepower.org](mailto:kathleen.jarschke-schultze@homepower.org)  
or: [kjs@snowcrest.net](mailto:kjs@snowcrest.net)

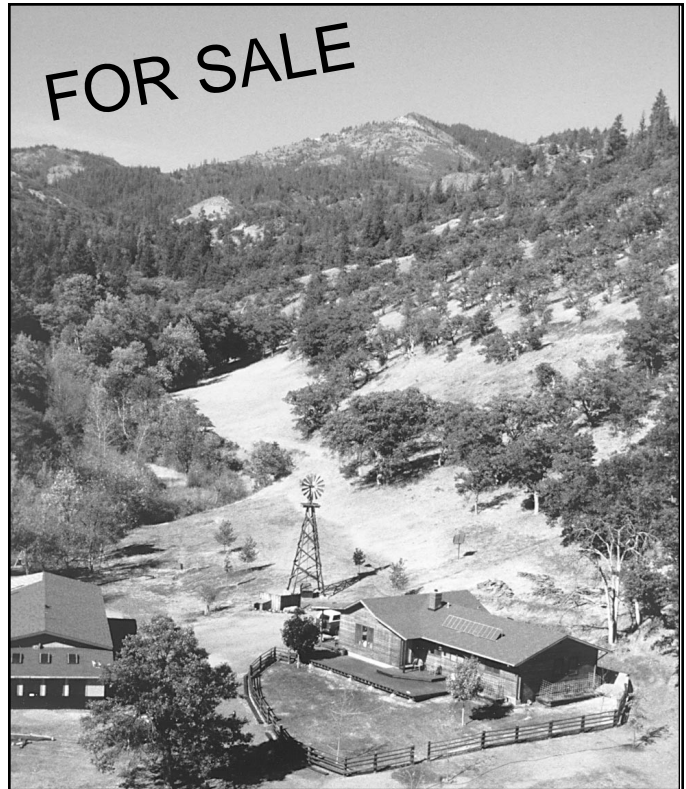

### Custom Homestead in Northernmost California

**\$250,000 / Best Offer**

**1824 sq. ft. home**, 3 bedroom, 2 bath, large pantry, laundry, library, cedar sided, raised redwood ceilings, 750 sq. ft. redwood decks (partly covered), beautiful landscaping, hardwood maple floors / tile / carpet, oak cabinets, tile counters, woodstove.

**Alternative Power System** with PV panels, batteries, inverter, generator, propane, designated power room. Wired complete for 110 vac & 12 VDC by R. Perez of *Home Power* magazine. Featured in *Home Power* magazine issues #13 & #21.

#### Includes:

**2028 sq. ft. shop building** with 675 sq. ft. enclosed slab / workshop, woodstove, 4 bay garage, built in shelves, greenhouse, tool & firewood storage.

**Pole barn**, holds 15-20 tons of hay, enclosed tackroom.

**Garden**, prime soil, deer proof fence, irrigated by creek or well.

**80 acres**, oak woodland, end of road isolation, creek (hydro potential), fenced and cross fenced, 2 acre paddock, stout new pipe and mesh corral with horse shelter, tie racks, miles of riding / hiking trails right out the door.

**Well water**, pumped by windmill and/or solar, two 1000 gal storage tanks, gravity feed house and garden.

**Laura or Jim Flett**  
(916) 842-4381  
(916) 842-6664

# HAPPENINGS

## AUSTRALIA

The World Solar Challenge is now a biennial (previously every three years) event and will run October 18–27, 1998. The World Solar Cycle Challenge will run in the alternate years to create an annual focus on solar car racing in Australia. The 1997 Cycle Challenge will run September 27 to October 6, 1997. The World Solar Challenge is the premier solar car race in the world and contributes vital research and development towards the quest for sustainable future transportation. An exciting development is the introduction of an Entry Competition open to school and tertiary entrants. To ensure another great entry response from educational institution the World Solar Challenge is offering free entry to the first school and tertiary teams to register in the 1998 World Solar Challenge. For further information on entry details or regulations please contact Ray Wieland, Event Manager, level 7 178 N Terrace, Adelaide 5000, South Australia, +61 8 8303 2021, e-mail: [wsc@saugov.sa.gov.au](mailto:wsc@saugov.sa.gov.au), web site: [www.wsc.org.au](http://www.wsc.org.au)

## CANADA

The "Alberta Sustainable House" is open for public viewing every Saturday 1:00-4:00 PM free of charge. The project emphasizes cold-climate features/products based on the founding principles of occupant health, environmental foresight, resource conservation, AE, recycling, low embodied energy, self-sufficiency, and appropriate technology. Already in place: R17 windows, multi-purpose masonry heater, solar hot water, greywater heat exchangers, LED and electroluminescent lighting, solar cookers, and others. Under development: hydrogen fuel cells, Stirling co-generator, Tesla bladeless steam turbine, and others. Contact: Jorg Ostrowski, Autonomous & Sustainable Housing Inc/Alternative & Conservation Energies Inc, 9211 Scurfield Dr NW, Calgary Alberta T3L 1V9, Canada • 403-239-1882 • Fax: 403-547-2671

The Institute for Bioregional Studies was founded to demonstrate and teach recent ecologically-oriented, scientific, social and technological achievements that move us toward ecological, healthy, interdependent and self-reliant communities. For info: IBS, 449 University Ave, Charlottetown, Prince Edward Island C1A 8K3, Canada • 902-892-9578.

23rd Annual Conference of the Solar Energy Society of Canada, June 5–7, 1997, Vancouver, British Columbia. Topics will include: housing & building, solar thermal, PV, other sustainable technologies, economics, policy & business, transportation & education. For more info: Solar Energy Society of Canada, Inc. (SESCI), 2nd Floor, 2415 Holly Ln., Ottawa, Ontario K1V 7P2, Canada • 613-523-0974 • 613-736-8938 • E-Mail: [solar@worldlink.ca](mailto:solar@worldlink.ca) • Web: [www.newenergy.org/newenergy/sesci.html](http://www.newenergy.org/newenergy/sesci.html)

## CUBA

Join Global Exchange for the Second Annual Renewable Energy Delegation to Cuba, September 21–29, 1997. Hosted by Cubasolar, Cuba's largest scientific association devoted to renewable energy. Meet with Cuban alternative energy practitioners who are pioneering Cuba's conversion to solar, wind, hydro, biomass conversion and other alternative methods of generating energy. Explore the role of renewable energy in meeting rural and urban energy needs in Cuba; solar energy in agriculture and agro-industry; bioclimatic architecture; ecotourism; cultural and energy consciousness; integration of renewable energy in to educational curriculum at the high school and university levels; research technologies and production of equipment for the utilization of renewable energy sources. Develop long term relationships with Cuba's alternative energy researchers and to help Cuba move toward energy self-sufficiency. For more information contact, The Reality Tour Program, Global Exchange, 2017 Mission St #303, San Francisco, CA 94110, 415-255-7296 or 800-497-1994, fax 415-255-7498, e-mail: [gx-info@globalexchange.org](mailto:gx-info@globalexchange.org), web site: [www.globalexchange.org](http://www.globalexchange.org)

## INDONESIA

The Asia-Pacific Initiative for Renewable Energy and Energy Efficiency Event '97, October 14–16, Jakarta Convention Center. The largest collection of RE and energy efficiency companies in Asia. Includes top speakers and focus on marketing strategies, project financing, policies and incentives for implementation in the Asia-Pacific region. For info: Alternative Development Asia Limited, 5/F 3 Wood Rd, Wanchai, Hong Kong • +852 2574 9133 • Fax: +852 2574 1997 • E-Mail: [altdev@hk.super.net](mailto:altdev@hk.super.net) • Web: [www.hk.super.net/~altdev/](http://www.hk.super.net/~altdev/)

## SPAIN

Renewable Energy in Europe as part of the Power-Gen Europe '97 conference, June 17–19, 1997, Madrid, Spain. Market opportunities, the increasing role of renewable energy in Europe, conference papers on fuel cells, hydro, solar, wind, geothermal, biomass, plant tours. For more information contact PO Box 9402, 3506 GK Utrecht, The Netherlands Phone, +31-30-265-09 63, fax +31-30-265 09 28, e-mail: [marcvsterel@pennwell.com](mailto:marcvsterel@pennwell.com)

14th European Photovoltaic Solar Energy Conference and Exhibition, Palacio de Congresos in Barcelona (Catalunya), Spain June 30th to July 4th. Contact: 20 WIP, Sylvensteinstr. 2, D-81369 M FCnchen, Germany • +49 89 720 1232 • Fax +49 89 720 1291 • E-Mail: [renewables@mail.tnet.de](mailto:renewables@mail.tnet.de) • Web: [www.wip.tnet.de](http://www.wip.tnet.de)

## UNITED KINGDOM

Weekend Workshops! Build a wind generator, PV, water heating system or any

alternative technology project. Work with others of varying ability in a well equipped workshop. By Robert Keyes GW4IED, of Keystone Systems. Held in Newport close to the M4 J25, Saturday 12–6, Sunday 9–4 with hotel & B/B close by, hard standing suitable for caravans available on site. Through 1997. Contact: Tel/fax 01633 280958.

## NATIONAL

Solar Energy & Systems, a college credit course by Mojave Community College. Covers fundamentals of RE for the individual home owner or small villages. Taught on the Internet using the latest technology. Includes weekly assignments for students to review various text books, videos, WWW pages, a weekly chat room, and email questions and answers from students. Tuition \$100 plus \$10 registration. Contact Don Timpson, 800-678-3992

Online Energy Info Resources—Information on energy efficiency or renewable energy technologies. US Department of Energy (DOE) has two sources of online access. The Energy Efficiency and Renewable Energy Clearinghouse (EREC) BBS Online Service offers users free access to text files, share and freeware programs and utilities, and a free publication ordering system. The service is accessible via the Web at [erecbs.nciinc.com](http://erecbs.nciinc.com) or by modem at 800-273-2955. The Energy Efficiency and Renewable Energy Network (EREN) is also accessible on the Web at [www.eren.doe.gov](http://www.eren.doe.gov) and provides links to hundreds of government and private internet sites. EREN also offers an "Ask an Energy Expert" online form that allows users to E-Mail their questions directly to specialists at EREC. For more information: 800-363-3732.

American Hydrogen Association, national headquarters, 216 South Clark Dr. #103, Tempe, AZ 85281 • 602-921-0433 • Fax: 602-967-6601 • E-Mail: [aha@getnet.com](mailto:aha@getnet.com) • "Prosperity Without Pollution" Web site: [www.getnet.com/charity/aha](http://www.getnet.com/charity/aha)

Energy Efficiency and Renewable Energy Clearinghouse (EREC) offers free info on Clean Energy for a Competitive America! Learn to use energy more efficiently. The DOE offers FREE info on windows, lighting, insulation and tips for energy savers. Get the fuel economy ratings of the new 1997 model cars! Free information on Home Energy Audits tells you how to assess the energy efficiency of your home. To obtain copy contact EREC: 800-363-3732 • PO Box 3048, Merrifield, VA 22116 • E-Mail: [energyinfo@delphi.com](mailto:energyinfo@delphi.com) • TDD: 800-273-2957 • BBS at 800-273-2955 • Web: [www.eren.doe.gov](http://www.eren.doe.gov)

Visit American Wind Energy Association home page on the World Wide Web: [www.igc.apc.org/awea](http://www.igc.apc.org/awea). Visitors to AWEA's home page can obtain information about the US wind energy industry, AWEA membership, small turbine use, and much more.



Last year's American Solar Energy Society & USDOE's & Interstate Renewable Energy Council National Tour of Solar Homes was a great success. To participate in the 1997 event (October 18) contact: American Solar Energy Society, 2400 Central Ave #G-1, Boulder, CO 80301 • phone 303-443-3130 • Web: [www.ases.org/solar/](http://www.ases.org/solar/)

The Federal Trade Commission is offering free pamphlets on: Buying An Energy-Smart Appliance, the EnergyGuide to Major Home Appliances, and the EnergyGuide to Home Heating and Cooling. Copies are available free by writing to: EnergyGuide, The Federal Trade Commission, room 130 6th St and Pennsylvania Ave NW, Washington, DC 20580 or call 202-326-2222, or 202-9326-2502 (TTY for the hearing impaired). The full text of these and more than 160 other consumer and business publication are available through the FTC ConsumerLine: <http://www.ftc.gov>

## SOUTHEAST US

The Self-reliance Institute of Northeast Alabama is seeking others in the southeast interested in Alternative Energy, earth sheltered construction and other self-reliant topics. Interested parties may contact SINA, Route 2 Box 185A1, Centre AL 35960 or E-mail to [cevans@peop.tdsnet.com](mailto:cevans@peop.tdsnet.com).

## ARIZONA

The State of Arizona is offering a tax credit for installation of all types of solar energy systems. A solar technician certified by the AZ Department of Commerce must be on each job site. For info contact ARI SEIA, 602-258-3422.

## CALIFORNIA

Rising Sun Energy Center presents ongoing Solar Energy Classes including electricity, water heating, cooking, and a kids' day. Contact for schedule and info: PO Box 2874, Santa Cruz, CA 95063 • 408-423-8749 • E-Mail: [sunrise@cruzio.com](mailto:sunrise@cruzio.com) • Web: [www.cruzio.com/~solar](http://www.cruzio.com/~solar)

Offline will have an Introductory Residential PV Design workshop on Oct. 18 for beginners. Costs \$35. Enrollment limited. Advanced Hands-On will be June 14 and 15. The Advanced will be held at Sun Mountain Tollhouse, CA. Participants in this workshop will upgrade the existing PV system at Sun Mountain. We will install an APT Powercenter & a Trace SW4024 and re-wire the existing modules and powerhouse to current NEC standards. This workshop is appropriate for the person who knows they will install their own system. Costs \$250 includes lodging. Enrollment limited to 10, so enroll early. Contact: 209-877-7080 • Email: [ofln@aol.com](mailto:ofln@aol.com). The Advanced workshop is a benefit for and part of a Straw Bale project at Sun Mountain. If interested in Straw Bale construction, call George Ballis at 209 855 3710.

Institute for Solar Living offers ongoing workshops on a variety of subjects. Call Real Goods, 800-762-7325.

Bill Mollison, world renowned Australian ecologist/farmer and his colleague Scott Pittman will teach two comprehensive Permaculture Design Courses. June 16-27 at the Ojai Foundation and July 14-25 near Half Moon Bay. Each course lasts 12 days. Some of the topics covered will be rehabilitating devastated soils, aquaculture, permanent natural pest control, water and energy self-sufficiency, production of auto and diesel fuels from crops, and "biological retirement"—the cultivation of long-term, low-risk, high-volume crops. For more information contact: The International Institute for Ecological Agriculture, 834 W California Way, Woodside, CA 94062, 415-365-2993, Fax 415-366-2241, e-mail: [dblume@igc.apc.org](mailto:dblume@igc.apc.org)

## COLORADO

Come join Solar Energy International at the 2nd Annual Carbondale Solar Potluck & Exhibition. July 4th 9am-5pm. Followed by a music concert in the park! 6-9pm. It's Energy Independence Day! Contact Ed Eaton, SEI, PO Box 715, Carbondale, CO 81623, 970-963-8855, fax 970-963-8866, e-mail: [sei@solarenergy.org](mailto:sei@solarenergy.org)

Solar Energy International (SEI) offers hands-on workshops on the practical use of solar, wind, and water power. The Renewable Energy Education Program (REEP) features one and two week sessions, PV Design & Installation, Advanced PV, Wind Power, Micro-hydro, Solar Cooking, Solar Home Design, Cob & Natural Building, Straw-Bale Construction and Adobe/Rammed Earth. Experienced instructors and industry representatives. Learn in classroom, laboratory and through field work. The workshops are for owner-builders, industry technicians, business owners, career seekers, and international development workers. The workshops may be taken individually or as a comprehensive program. \$450 per week. SEI is a non-profit educational organization dedicated to furthering the practical use of RE technology. Contact: SEI, PO Box 715, Carbondale, CO 81623 • 970-963-8855 • Fax 970-963-8866 • E-Mail: [sei@solarenergy.org](mailto:sei@solarenergy.org)

Visit the new National Wind Technology Center operated by the National Renewable Energy Laboratory, just outside of Golden, CO. The facilities assist wind turbine designers and manufacturers with development and fine-tuning and include computer modeling and test pads. Call in advance, 303-384-6900 • Fax: 303-384-6901.

8th Annual Solar Energy Fair, August 31 & September 1, Labor Day Weekend! Music from the solar stage, alternative and solar home tours, UFOs, vendors, energy discussions, raffle and a fun time! Contact

Jason Jepsen, PO Box 9999, Crestone, CO 81131, 719-256-4038 or 4838

Energy Efficient Building Association Inc. (EEBA) Conference November 5-8 and EEBA Exposition November 6-7, 1997 in Denver, Colorado. For more information contact EEBA, 2950 Metro Dr Ste 108, Minneapolis, MN 55425, 612-851-9940, Fax 612-851-9507, e-mail: <http://www.eeba.org>

## CONNECTICUT

Building Energy '97: Insuring a Sustainable Future; Two Conferences, Workshops and a Trade Show. NESEA's Quality Building Conference and NESEA's RENEW '97 will bring together experts and decision makers from the advanced building and renewable energy industries to describe how quality construction practice, emerging technologies and global market opportunities will shape communities of the future.

Renew '97 and Building Energy '97. Building Energy '97, a launching point for sustainable development in the next millennium. Green buildings and RE. Architects and builders, code officials, land-use planners, and landscape architects will discuss how communities can work together to make sustainable development standard practice. Insurance and financial experts will participate in the analysis of RE and sustainable building not only as strategies for loss mitigation, but as the key investment opportunity for "insuring the future." Renew '97 will focus on the latest in renewable technologies in real market applications, highlighting a niche in an evolving utility environment and a booming global marketplace. Contact: NESEA, 50 Miles St, Greenfield, MA 01301-93212 • 413-774-6051 • Fax: 413-774-6053.

## FLORIDA

14th International Electric Vehicle Symposium, December 15-17, Walt Disney World Dolphin, Orlando, FL. Contact: Pan Turner, EVS-14 Symposium Manager, c/o First Option, 15 N Ellsworth Ave Ste 202, San Mateo, CA 94401 • 415-548-0311 • Fax: 415-548-9764 • E-Mail: [firstopt@aol.com](mailto:firstopt@aol.com)

The Sixth Annual SunDay Challenge, September 26-29, 1997. This new breed of auto rally will showcase and promote alternative energy vehicle technology. The rally will start at the Florida Solar Energy Center in Cocoa, FL and finish at Walt Disney World in Orlando. For more information contact: SunDay Challenge Race Committee, Florida Solar Energy Center, 1679 Clearlake Rd, Cocoa, FL 32922-5703, 407-638-1458, Fax 407-638-1010, web site: <http://www.fsec.ucf.edu>

## IOWA

IRENEW is presenting the SIXTH Annual Renewable Energy Expo and Alternate Fuel Vehicle Showcase on August 23 & 24, 1997 at the Johnson County 4H Fairgrounds, Iowa City, Iowa. This is a new time and place but

the same friendship, hospitality, and unlimited sharing of knowledge from past years. For more information contact: IRENEW, PO Box 2132, Iowa City, Iowa, 52244. Telephone 319-875-8772 or E-mail [bsnyder@mwci.net](mailto:bsnyder@mwci.net)

IRENEW and Trace Engineering are presenting a 2 day workshop on PV-Grid intertie systems at the Indian Creek Nature Center, Cedar Rapids, Iowa on September 6 & 7, 1997. This 1000 Watt system is the first grid- intertie workshop in the midwest with material furnished by IRENEW, Solarex, Square D, and Trace. Tuition is \$50 for the two day workshop. IRENEW, PO Box 2132, Iowa City, Iowa, 52244. Telephone 319-875-8772 or E-mail [bsnyder@mwci.net](mailto:bsnyder@mwci.net) for information on the workshop.

### MASSACHUSETTS

NESEA is converting its headquarters into a showcase of environmentally responsive building. Members are converting a historic railroad hub into a working demonstration of a healthy, daylight, office building flanked by a park which celebrates transportation history while demonstrating principles of urban ecology. Opportunities for involvement: Saturdays at NESEA: A volunteer program through which construction novices learn green building tricks of the trades working with professionals. Major transformations of the building and park will be undertaken as "barn-raising." Contact: NESEA, 50 Miles St., Greenfield, MA 01301 • 413-774-6051 • Fax: 413-774-6053.

### MISSOURI

The Missouri Renewable Energy Association is a non-profit educational organization, promoting energy sensible technologies as a solution to global environmental pollution. Improved energy efficiency. water conservation, recycling, and composting are just a few of the topics on our agenda. We encourage local government, businesses, schools, and individuals to become involved by joining the MO.REA today. Contact Ray Wathowski, PO Box 104582, Jefferson City, MO 65110 • 573-634-5051

### MONTANA

Life Skills Workshops offered by Sage Mt. Center. Workshops include Making Log Furniture Aug 16, Solar Electricity June 21 & Sept. 13, Strawbale Construction July 12, Cordwood Construction July 26, and Earth Friendly Home Building Aug. 2. All in-depth and hands-on. \$45. Contact: Christopher Borton or Linda Welsh, Sage Mt. Center, 79 Sage Mountain Trail, Whitehall, MT 59759 • 406-491-0954

### NEW MEXICO

Solar powered rock and roll! K-TAOS, the world's most powerful solar radio station (50,000 watts of progressive adult rock & roll and alternative music), presents the First Annual K-TAOS Solar Music Festival, June 21 and 22, at the Greater World, in Taos,

New Mexico. Nationally known recording artists concerned about the environment will perform on both a solar powered stage and conventionally powered stage. The Festival's Solar Fair will offer a wide array of exciting and fun demos and displays of the power and potential of solar energy and other renewable resources. The Festival will also have an international food and craft fair. The Solar Music Festival will benefit the New Mexico Solar Energy Association, so they can build the Solar Magic Bus, a mobile solar education center. The bus will visit schools, youth groups, Native American communities and other public venues across New Mexico and the southwest, teaching kids about solar energy. For more information contact, Lauren Gwin, Festival Coordinator, 505-758-5826

New Mexico Solar Energy Association's 25th Annual Life Technics Conference & 11th Peter VanDresser Workshop, October 3-5, Ghost Ranch Conference Center, Abiqui, NM. A solar & sustainable village conference. \$45 for non-members, late fee after Aug. 22. Contact: NMSEA, PO Box 8507, Santa Fe, NM 87504 • 505-776-2012 • E-Mail: [ksolar@laplaza.org](mailto:ksolar@laplaza.org)

### NEW YORK

The New York State Electric Auto Association (NYSEAA) is dedicated to sharing current electric vehicle technology. Monthly meetings. For date and location call Joan, 716-889-9516.

Earth's Pulse: an Intercontinental Convergence. Caring for the planet and her children by sharing knowledge. Aug 18-24, Brushwood Folk Center, Sherman, NY. Demonstrations, workshops, discussion groups, guest speakers, music, earth ceremonies, and more. A benefit for Eco-Educational Youth Camp. Contact: Don Mackenzie, 4700-A8 Babcock St. NE Drawer 197, Palm Bay, FL 32905 • 800-759-8888 ext. 3211104 (national pager) • E-Mail: [EPIC1997@aol.com](mailto:EPIC1997@aol.com).

### OHIO

The Great Lakes Electric Auto Association's mission is to contribute to the freeing of the US automobile market from dependency on petroleum through advancements in electric and hybrid/electric technology. For more info: Larry Dussault, GLEAA, 568 Braxton Pl. E., Westerville, OH 43081-3019 • 800-GLEAA-44 • 614-899-6263 • Fax: 614-899-1717 • E-Mail: [DUSSAULT@delphi.com](mailto:DUSSAULT@delphi.com)

Solar and wind classes at rural solar and wind powered home with utility back-up. Maximum 12 students. Advance register. \$45.00, \$50 per couple, lunch provided. Class #1: technical info, system design, system sizing, and NEC compliance, etc. Students will see equipment in use. Every 2nd Saturday of each month. Contact: Solar Creations, 2189 SR 511 S, Perrysville, OH 44864-9537 • 419-368-4252.

### OREGON

Aprovecho Research Center is a non-profit educational institute on forty acres nestled in the forest of Oregon. Internship programs March 1, June 1 and September 1. Also, a six week winter internship in Baja, Mexico which focuses on studying and researching appropriate technology applications, learning Spanish, teaching in a grade school, and working in fruit orchards and gardens. Contact: Internship Coordinator, Aprovecho Research Center, 80574 Hazelton Rd., Cottage Grove, OR 97424 • 541-942-8198.

The Lane Community College Energy Management Program is offering a PV design course for the Spring term. Content includes PV electricity basics, modules, batteries, controllers, inverters, lighting, appliances, and installation guidelines. Includes a tour of PV installations and culminates in a design project, David Parker, Instructor. Contact: Roger Ebbage, LCC, 541-747-4501 ext. 2451 • out of area 800-769-9687 • E-Mail: [ebbager@lanec.edu](mailto:ebbager@lanec.edu) • Web: [lanec.edu:1080/webpages/lcc/science/home.htm](http://lanec.edu:1080/webpages/lcc/science/home.htm)

The second annual SolarFest '97. Saturday June 21, 1997, is being held on the Downtown Pedestrian Mall in Eugene, Oregon. A variety of fun, educational, and product sales booths, all relating to alternative and renewable energy sources. Scheduled events include many specialized demonstrations, a solar powered live radio broadcast from KRVM, solar-cooking contest, slide shows, food booths, music, human-powered vehicle rides, and much more. Call Gary at 541-334-6960 for more information.

### TEXAS

Windpower '97 Annual Conference and Exhibition, June 15-18, 1997, Austin, Texas. Presentations will highlight: technology advances, hybrid and small system project updates, international markets, wind resource assessment, environmental compatibility, legislative and regulatory issues, electric industry restructuring, green marketing, financing and economic perspectives, wind farm operations, utility project experience. The exhibition will feature the most active manufacturers, project developers and consultants in the wind energy industry. For more information and registration materials contact: Linda Redmond, American Wind Energy Association, 122 C St NW Fourth Floor, Washington, DC 20001, 202-383-2500, Fax 202-383-2505, e-mail: [lindaredmond@mcimail.com](mailto:lindaredmond@mcimail.com)

### VERMONT

Free PV Workshops for beginners wanting to see working systems and for experienced off-grid people looking to share information and to see new, or different ways of solving problems. Hosted by David Palumbo of Independent Power & Light, first Saturday of

most months. Interest will determine which of the following topics will be discussed and demonstrated (as practical): site selection, PV modules, batteries, safety, charge controllers, inverters, DC lighting, balance of system components, system monitoring and maintenance, water topics, snow topics, ponds, living in cold climates, living with our woods, heating with wood, and root cellars. This is a freebie so bring your own lunch and coffee. Contact: David Palumbo, RR1 Box 3054, Hyde Park, VT 05655 • Voice or Fax 802-888-7194, e-mail: indeppower@aol.com

PV Home Electric Systems Seminar and Workshops by Sunnyside Solar. Beginners program August 2. Cost \$95 each or \$175 for two persons. Advanced programs geared toward contractors, carpenters, electricians, plumbers, and architects June 7-8 and Sept. 20-21. Cost \$190. All programs include lunch, a packet of information, slide show, etc. For info and reservations contact: Carol Levin, RD4 Box 808, Brattleboro, VT 05301 • 802-257-1482 • Fax: 802-254-4670 • E-Mail: sunnyside@sover.net

**WASHINGTON STATE**

School of Natural Living is offering a series of workshops. Earthen Plastering June 14-

20, Strawbale Building June 23-29, Cob Construction July 16-22, Timber Framing Aug. 15-22. \$450 per week or \$195 weekend only, includes camping, lunch, and use of campus facilities. Contact: 1356 Janicki Rd., Sedro-Woolley, WA 98284 • 360-856-5482 or 360-854-0413 • E-Mail: jkelley@ncia.com

Renewable Energy Fair & Solstice Celebration presented by The River Farm Community Land Trust, June 20-21. 50 classes, including hands-on workshops on PV, hydro, batteries, inverters, charge controllers, energy conservation, and off grid living. Includes info and demos on wind power, car conversion, bio-fuels, fuel cells, and product literature. Admission \$75 before May 20 and \$90 later includes camping, food, workshops, classes, and entertainment. Contact: The River Farm, c/o Renewable Energy Fair, 3231 Hillside Rd., Van Zandt, WA 98244 • 360-592-2716 ext. 4.

**WISCONSIN**

The Midwest Renewable Energy Association Workshop Schedule. Pre-Energy Fair Workshops: Off-Grid Wind Systems June 6-8 • Utility Intertie Wind Systems June 13-15 • Hands-On Photovoltaic Systems June 10-13 & 16-18. Call MREA for cost, locations, instructors and further workshop descriptions.

Membership and participation in the MREA are open and welcome to all. Significant others may attend with you for 1/2 price. Contact: MREA, PO Box 249, Amherst, WI 54406 • 715-824-5166 • Fax: 715-824-5399

8th Annual Midwest Renewable Energy Fair, June 20-22, Portage County Fairgrounds, Amherst, WI. Workshops, speakers, exhibits, and demonstrations on RE and energy efficiency for children, educators, and the general public. Includes bus tour of RE homes, on site model home tours, food and entertainment. See above for pre-fair workshops and contact info.

Adult Solar Sprint and Junior Solar Sprint, at the Midwest Renewable Energy Fair on June 21. Sponsored by the Midwest Renewable Energy Association, Home Power Magazine and The University of Dubuque. For rules, entry, and kits contact: John Root, University of Dubuque Environmental Policy Dept., 2000 University Ave., Dubuque, IA 52001 • 319-589-3320 • E-Mail: PVperson@aol.com



# Iowa Renewable Energy Association Sixth Annual Energy Expo

August 23 & 24

4-H Johnson County Fairgrounds  
Highway 1 South, Iowa City, Iowa

Workshops on wind, active & passive solar, DHW, PV, commercially built, high school & junior high electric vehicles, solar cars, utility issues on restructuring, energy conservation, classes & projects for teachers & students, nationally known speakers on energy.

**Other I-RENEW Events:**

**The Iowa Electrathon Competition**, May 17  
Iowa and Michigan high school electric cars.  
Hawkeye Downs race track, Cedar Rapids, Iowa.

**1000 Watt Grid Intertie PV Class & Installation**, September 5, 6, & 7,  
First PV Grid intertie class in the midwest. Materials & equipment donated by I-RENEW, Trace, Solarex, & Square D. Presented by Trace Engineering & I-RENEW.  
Indian Creek Nature Center, Cedar Rapids, Iowa



## Iowa Renewable Energy Association

PO Box 2132, Iowa City, Iowa 52244 Office: 319-338-3200 or Tom Snyder (president): 319-875-8772



# the Wizard speaks...

## Book Recommendation

I read an excellent book last month. It was entitled *The Coming Energy Revolution* and sub titled *The Search for Free Energy*. This is a very good introduction to the subject. The author's name is Jeane Manning. The book was published by Avery Publishing in Garden City Park, NY. The ISBN number is 0-89529-713-2.

This book covers the field of "free energy" research both past and present. Theoretical considerations are discussed clearly and simply without resorting to complicated mathematics. Individual researchers, both past and present, are discussed and their inventions and theories presented.

The political and economic considerations and intrigues related to the development of "free energy" are also covered. There is a glossary, an extensive resource list, and a large bibliography. This book is well written and I enjoyed reading it very much. I hope you will, too.



**Solar - Powered Soap?**

The natural ingredients of our soaps and bodycare products derive their energy from the Sun, as do our home and business.

Discover the many items for home and personal care in our catalog:

**Simmons Handcrafts.**  
42295 Hwy 36, Bridgeville, CA 95526

BACK HOME MAGAZINE

camera ready  
b/w

3 wide  
5.8 high

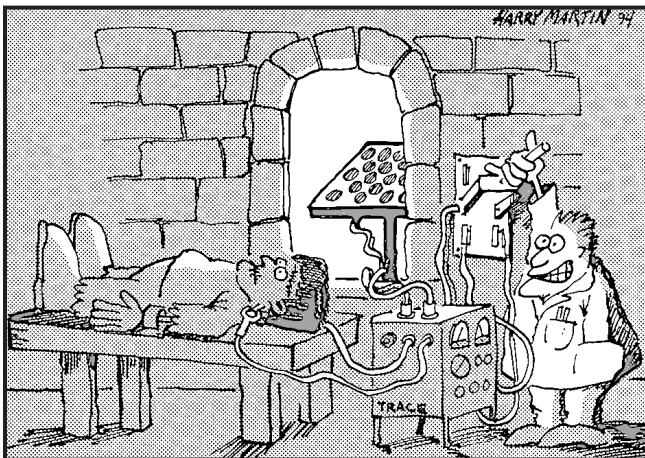

## Need a renewable energy quick-start for the ole' brain?

### Home Power Quick-Start Subscription Special

our last six issues, plus a one year surface subscription...

all for \$45 inside USA

(Call for International Rates)

Home Power Magazine

P.O. Box 520, Ashland OR 97520 USA

**800-707-6585 in USA, or 916-475-0830**

VISA or MC

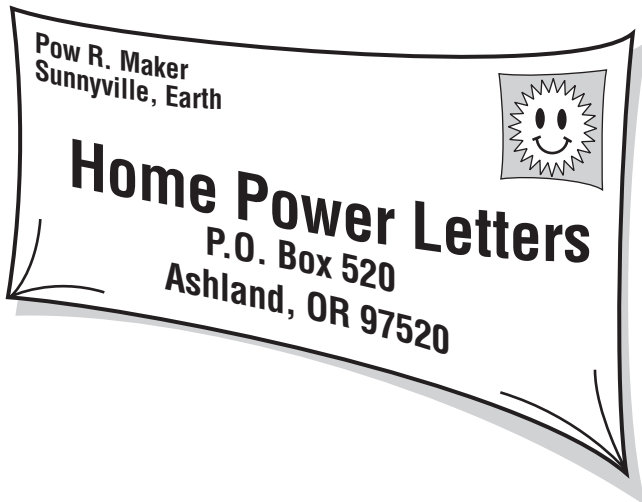

### A Big OOPs!

In the February/March 1997 issue of Home Power, the owner of the solar system which was the subject of the article "A Low Budget Cabin System" had not given his consent to publish the details of the system, including costs, pictures, and site location. The author and Home Power apologize to the owner. In the future, Home Power will require written home owner approval before publishing articles of this type.

### Electronic Desulfators

Thanks to Mike Brown for opening a discussion on "electronic desulfators" (EV Tech Talk, *HP* #58) Since sulfation is a curse upon all lead-acid battery users, desulfation is an important topic. Some of Mike's comments deserve clarification.

Mike says that the electronic desulfators "seem geared more to prevention than cure," and that they are "intended to prevent sulfation in a healthy pack, not cure it in a sick one." This suggests that pulse technology cannot remove existing sulfate deposits.

The United States Air Force would disagree, at least concerning the Solargizer™ products. Enclosed is a test report produced by the "Management & Equipment Program at Eglin Air Force Base. Note this comment: "In conclusion, the Solargizer™ worked by removing sulfation from the battery plates as the manufacturer claimed."

Even though these products will reverse pre-existing sulfation, Mike's advice to "think prevention" is very sensible. Sulfation occurs gradually, on a molecule-by-molecule basis. Those who want peak performance and efficiency should implement a desulfation plan BEFORE the battery has sulfated to the point of crisis. Properly designed electronic desulfators clean the plates AND keep them clean.

Regarding electric vehicle applications: "A drawback is the necessity for more than one unit per battery pack for

a high voltage EV system. The expense and complicated wiring seems prohibitive to me."

For a vehicle that uses 15 or fewer 6 Volt batteries in series (90 Volt nominal or less), a single 8 ounce PowerPulse™ unit is appropriate. A single unit has only two wires to connect. Assuming that "golf cart" batteries cost \$75 each, a \$220 high-voltage PowerPulse™ unit could protect over \$1100 worth of batteries. Besides lasting longer, de-sulfated batteries exhibit full capacity, maximum energy efficiency, and other benefits.

Vehicles with battery packs in excess of 90 Volts WOULD need two (or more) units, with two wire connections per unit, but the cost/benefit ratio for such packs is still attractive, since the battery investment is greater in a higher-voltage system.

Since the discussion will probably not end here, Home Power readers should be careful not to confuse currently available products with earlier units. Although lower in cost, modern devices are more durable than their predecessors, I believe. An old-style desulfator that seems to not work may simply be broken. Such first-generation devices should be tested to ensure that they are working before entrusting batteries to their care. Mick Abraham, Abraham Solar Equipment, 124 Creekside Place, Pagosa Springs, CO 81147

### 12 Volt Grist Mill

In August, our family purchased a 12 Volt DC home stone grist mill from Jansen Grist Mills in North Carolina. I am pleased to report over six months (of weekly bread baking for a family of five) later, we are VERY HAPPY with our purchase.

We perused many alternative energy catalogs in vain for a 12 Volt DC stone flour mill. Finally we asked the people at Little Stream Bakery in Lanark County, Ontario (delivering fresh sourdough and specialty breads from fresh ground flour throughout Southern Ontario) where they suggest we look. Having researched the market the year before for their own grinder, they highly recommended Jansen Grist Mills, P O Box 696, Hiddenite, NC 28636 (704) 635-7137.

We called Tass Jansen. He said they'd never done a 12 VDC model before, yet since all it would take would be a change in motor, it would be no problem. And it was no problem. In three weeks we had our grinder, powered by a 1/2 horsepower, 40 amp, 12 VDC motor. It draws about 35 amps on average while grinding wheat, rye, or spelt grain into fine flour at a rate of about a cup a minute. (Different rates for different grains and degree of grind). The model we have is the "Chris Mill."

The taste, raising abilities, and nutrition are all superior in fresh flour compared to store bought. And the cost difference between grain and flour is quite noticeable for a family of five who loves fresh bread, pancakes, buns, pizza, cookies, cake, etc.

Any problems we experienced with the mill were quickly answered by a call to Tass Jansen (you may need to leave a message and they'll call back). Once I unscrewed the cover and saw how simply it was set up, I felt confident in tightening and adjusting the pulleys and belts.

We pour up to five cups of grain into the hopper and flip the switch. When the sound changes in five minutes we flip the switch off, open the sliding door (which prevents flour dust escaping), and remove a large pan of vitamin-rich fresh flour ready for baking.

So, I feel inspired to recommend this excellent product that has enhanced our lives. We appreciate being able to continue our home on 12 VDC rather than often inverting to ac. As it is, we power our home with six 50 watt solar panels and only needed to run our Delco generator five times this passed cloudy winter, tho' we also use propane for some of our lighting. Robbie Anderman, Killaloe, Ontario, Canada

### **PV Ice Chest?**

I've got an island that would make most HP readers drool with the challenges it presents no water, no power, no roads. No nothin' except an abundance of peace and natural beauty. We're planning to build a log home there in the next few years, but in the interim need to figure out some temporary, low cost solution for refrigeration. There is no reliable local (within 1/2 hour by boat) source for ice for our ice chest. Whatever we bring must be taken away, as there is no building in which to store anything for the eleven months of the year when we're not there.

I've read something somewhere about 12V ice chests. Is there any system you or your readers can suggest for a small, portable solar array and such an ice chest, hopefully which could operate without the need for a battery bank. Am I wishing for the impossible?

Thanks for your help. It drives me nuts to have to give away most of the salmon we catch because of our inability to keep it cool for a few days! Charlie Walters, 12015 109th St. K.P.N., Gig Harbor, Washington 98329, email: twalters@seanet.com

*Hello Charlie. Check out the Kool-A-Tron letters here. It would take about two or three PV modules (in a sunny place) to power such a cooler. I'd recommend at least a small battery, perhaps a sealed lead-acid gel cell in the 20 Amp-hour range. While not packable, this whole system could be easily transported in a pick-up truck.*  
Richard Perez

### **Koolatron Experiences**

In response to the letter from Richard Georgina in *HP* #58, here's my experience with a Koolatron Peltier effect "ice chest". I bought one about six years ago for my partner Jimmi Mead's small PV system in southern British Columbia. She used it for about six months the first summer, around eight hours per day, keeping milk, cheese, jam, etc. cool through the hottest part of the day.

We did not run it 24 hours a day because our system would not support the 70+ Amp-hours per day it would demand. By the end of the summer, the fan motor was worn out, with both bearings and brushes beyond repair. We replaced the motor with a new one from Koolatron, which wore out during the second summer. The third summer we installed a 12 VDC muffin-type fan salvaged from a discarded computer power supply. That fan is still going strong, in spite of much heavier use in the last few years. That is what I expected from my experience with similar fans in lab equipment, which seem to last five to ten years in continuous use. Similar fans can be bought new from electronic supply houses for under \$15. I would highly recommend a ball bearing fan; its longer life should more than make up for its slightly higher price.

Jimmi has added two inches of salvaged "styrofoam" around the outside of the cooler. With the extra insulation it will run acceptably on 6 V, using about 1.2 A instead of the about 3 A it uses on 12 V, and will hold an inside temperature in the 40's if used in a reasonably cool, shaded place. The current used varies somewhat as the system voltage rises and falls during the day. The fridge will keep unpasteurized milk for several days and cheese at least two weeks, good enough for our use.

For a couple of years we ran the cooler 24 hours a day about six months per year, switching it between the upper and lower 6 V halves of our 12 V battery bank each morning. Used that way, it consumes about 16 Amp-hours a day at 6 V. Our small PV system will support this along with other uses (irrigation pump, radio, sewing machine, blender, microwave, lights, computer, etc.) during the part of the years that a fridge is needed.

I was concerned that switching between halves of the battery bank only once a day would cause our homebrew PV controller to overcharge the half of the bank that wasn't connected to the cooler at the time, and built an electronic unit that switches the cooler between halves of the battery bank several times per second. Switching that often, the batteries should not overcharge significantly. We have fuses in both the +6 V and +12 V leads from the battery to protect from fire in case of a failure in the system. We have operated the fridge this way for over a year, and are well satisfied with the results.

Overall, the modified Koolatron has met our needs well. We have not had the trouble with hinges that you mentioned. Possibly our early unit was better built than current ones. Our fridge is not as efficient as a compressor-type unit. For comparison, the Novakool as sold by my friends Steve and Elizabeth Willey (Backwoods Solar Electric Systems) maintains about three times the volume at a (probably) lower temperature on less than twice the energy per day. The Novakool costs \$635.00, however, and Peltier-effect "ice chests" can still be found on sale for the price I paid: slightly

under \$80.00. If a fridge the size of a small ice chest will met your needs and you are willing to modify it with additional insulation and a better fan, a Peltier cooler is a good choice.

PS: I like your mag, and will continue to subscribe. As I've said several times before on renewal notices, though, I would like to see more on small-to-tiny systems like ours. Even AE folks are subject to infection by the bigger-is-better virus. It's amazing how much you can cut down on power usage and system cost with relatively little inconvenience. David R. Coahran, Pullman, Washington

#### Another View

I experimented quite a bit with a Cool A Tron type refrigerator before I gave it up (re: Letters issue #58, page 99). My friends called it "Mark's Folly." I insulated it with six inches of foam insulation. I buried it in the ground. I used a fan to blow air down to the cooling fins through a piece of flexible drying venting hose. I used another fan to help evacuate the warm air through another hose. Then I gave it up. I dug it out of the ground and sold it.

My particular unit would only cool the inside 40°F cooler than the outside temperature. After running continuously all day in summer it would be 50°F inside—not cool enough. It didn't come with a thermostat so I bought a timer to kick it off & on through the night. It would be about 25°F inside in the morning and slowly warm up throughout the day. It was a small unit so there wasn't much thermal mass to prevent the temperature from changing fairly quickly. To get the marginal performance from it that I got, it ran about 18 hours/day. At 5 Amp-hours per hour (including the fans) this was an expensive use of power.

I saved my pennies for a couple of years after that and bought a 3.5 cubic foot Nova Cool. I super-insulated it and put an hour meter on it to see the run time per day. In winter it runs about two hours/day and on the hottest summer days about five hours/day. I set the thermostat at 35°F. It is a real jewel that sits there quietly and functions perfectly. It draws 4.8 amps.

Thought this information might be useful for those on a refrigerator search. Mark Heinlein, Bend, Oregon

#### Vertical Axis Gens

Your answer to Chris White re: Vertical Axis Gens (HP#58) was correct.

However, as a long-time experimenter with vertax wind motors of my own design, having built rotors up to 16 feet high, I feel that such machines have their place, but perhaps not in this country.

I specialize in LOW technology and I have used them to drive piston type water pumps, air compressors (to supply air to a service station) as well as refrigerators. Having no tower and being close to the ground they are

easy to build with little skill and easy erect and maintain. Lower wind velocity near ground level and lower efficiency can be compensated by increasing their size.

One of my rotors was built entirely from 4X8 feet plywood sheets and an old car rear axle served as the mount, complete with drum brake, and there is no reason why such a type could not be made using a bamboo covered with banana leaves or other biomass for locations where only very low tech and low cost can be justified.

Let's face it, most of this world cannot afford air foil gens on high towers, sine wave converters and battery storage.

I'm willing to share my experience with low tech vertax machines. Steve Sieradzki, PO Box 691792, Orlando, FL 32869, 407-856-0933, Fax 407-856-0933

#### Ad Ghettoes & Renewal Notices

Love the current format, don't change a thing. I did notice, and truly appreciate, the continuity in the article layout. Ad ghettoes, so what. The issue on the mailing label debate; I guess you have readers who spend far too much time having someone else do for them, bet they're still on the grid. Charge them more for you being their baby sitter, say a buck. Make people see the cost of their laziness while not passing that cost onto the rest of us. That is what we Rotarians call fair.

Keep up the good work, have fun in the new bath house, John Maggitti, e-mail: maggitti@ix.netcom.com

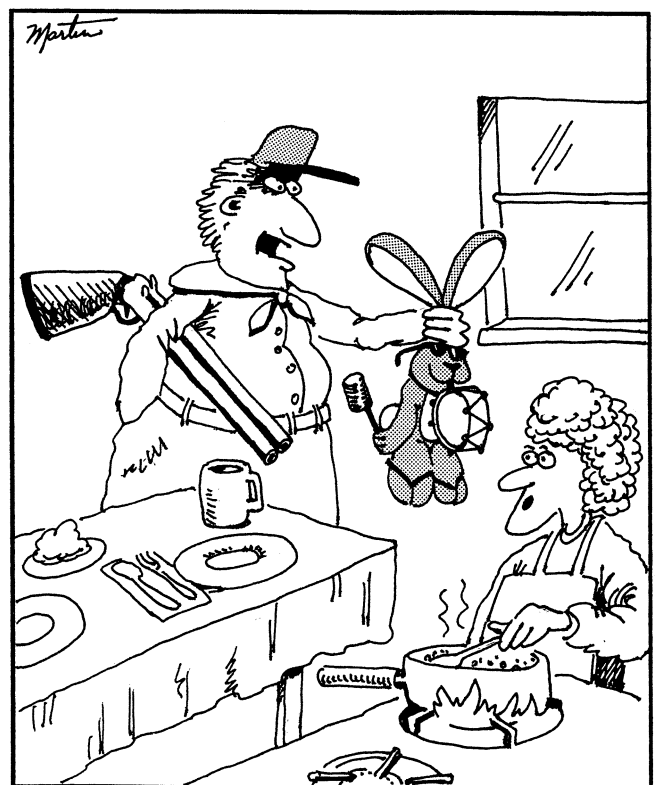

"It wasn't hard to track, it left a trail of dead batteries everywhere it went."

E-Mail: 74172.1607@compuserve.com

**Keep it up!**

Here's one vote for keeping design philosophy as is. I love it. I hate "continued on page 317", especially when you find a tiny paragraph embedded in ads. Some mags actually need a few ads to break up the look of pure text, but for some reason I find your design definitely does not need it. As for your advertisers, they needn't worry. I do look at most ads for the same reason I read *HP*—to learn about new and interesting things happening with RE. I'm sure many readers would agree. Sorry to take up your valuable time, but hey, I like *HP* and I wanted you to know. RV Solar Consultants, e-mail: rvsolar@rvsolar.com

**Ozonal Feedback**

It's fortunate when *HP* comes on Saturdays—I can read it cover to cover without guilt.

RE: Renewal notices—I'll read my label. I also read the label for the library subscription we're sharing and will be renewing at the appropriate times for each. I'm waiting for the SOLAR-II CD-ROM and then I'll be gifting the library with a few CDs as well.

RE: Advertising ghettos—Leave the ads to rot in the ghettos! Seriously, "continued on page 376" is one of the biggest wastes of ink and one of my pet peeves. Keep the articles together as you have been doing! Second best is an article, especially a long textual article, broken up by a whole page of ads. Snaking the article around the ads is the pits; don't do it! Please!!

RE: *HP* without trees—count me OUT of electronic distribution. I'm a dinosaur when it comes to reading; I particularly despise computer products that don't come with paper manuals. Sigh. I \*know\* I could save some trees this way, but...

Finally, when my round-tuits finally come round, I'm planning ecological revenge upon the neighbors. Several of the folks in my neighborhood have gone to obscene lengths with Christmas decorations. I really DON'T want to know what their "decorating electrical" bill is. I have in mind a solar panel, a small charge controller, a single floodlamp on a small Nativity scene, and a HUGE sign: "The real meaning of Christmas, brought to you by the Son". I'm not sure they'd get it though.

Keep up the good work! Jonathan Allan,  
e-mail:Kpa@millcomm.com

**More Ozonal Feedback**

Just received Issue #58, Congrats !!! It has got to be your finest issue to date, and the previous issues were not too shabby either. Every time I get an issue I plan to let you know that I think it was the best issue yet, but they keep getting better. I figured I had better write at some point, none-the-less. I could comment about every article, but suffice-it-to-say they were all tops!

I really liked the inclusion of "Ozonal Notes". Although it is none of the readers business how you put out the magazine, it is nice to have you share that information. It

makes me feel a part of the publication to know how you crank it out each month (or is that every two months )

Some comments on Ozonal Notes subjects: Re: Advertising Ghettos. Don't listen to the complainers. A magazine needs advertising to survive. You are most admirable to maintain a ratio of editorial material to advertising, I do not know of another magazine that does that. I find the advertising in Home Power to be almost as educational as the stories. The advertising is not intrusive or bothersome at all. I suppose in a perfect world there would be no advertising, but how the hell would we hear about a company's new products and developments if they didn't take out ads to tell us about them. As much as I am indifferent to them, even Proctor & Gamble has the right to tell us when they make a "new and improved" version of Tide detergent.

If I was to develop a new PV panel with a 90% efficiency rate I would want the right to take out all the full page ads I could to tell the world about it. Is that bad ? Nuff said.

Re: Renewal Notices: I like the idea of renewal notices. Save some trees, what about offering an electronic version. I would not mind receiving an e-mail notice an issue or two before my sub runs out. You could even automate the process via an e-mailbot program on your server. Giving the readers a choice of requesting the postcard notice is a good plan, I like it too.

Re: An electronic version of Home Power. Not a bad idea, but history has shown that video text has never been too popular. I like to read in bed, on the couch, on the chaise lounge, and on the airplane, etc and when I figure out how to get my monitor easily to all those places I will want the electronic version. For now, I sure like the printed version and those nice hi-res photos. I can see why you want to offer it, your arguments in favor of an electronic version are sound. Let us know how the experiment progresses.

Re: Wasting time. I have wasted enough of your time rambling on, besides, you have a magazine to put together, and springtime to enjoy.

Keep up the good work. Wild Ed (aka: KWR),  
Bellingham, Washington, e-mail: crackers@nas.com

**Water Heating**

Re: latest Home Power magazine articles (April/May #58) on active water heating systems. On page 25 the suggestion of using a "snap switch" to reduce cost is fine when using a solar panel to only heat air. Room air is always below 90 degrees (HOPEFULLY) so the solar panels will always put hot air into the house. In the case of heating water, the tank might be above 110° F from the sunny day before. If the system is started with a "snap switch", the system will pump the heat FROM the tank out to the solar panels! Using a differential control (basically a thermistor that measures voltage by heat) will solve this problem (for little more than the \$28 mentioned).



If the differential control is equipped with LED readout, then the problem of flow rate is also easily controlled. Engineers for American Solar King and Novan used the same method used by Central Air Conditioning installers.

In the case of solar panels using two Thermistors, one at the input (lower corner) and output (upper opposite corner) of the panels allows a measurement of the temperature differential. In this case a temperature difference between 15° and 17° F will give maximum heat transfer to the tank of water and you do not need to know or measure flow rate. To be very precise you should actually measure the temperature going into and out of the tank of water, but most often the thermistors are mounted on the panels for monitoring the system.

Finally, on page 32, the material listed for the absorber plate for homemade panels should be viewed with caution. (30 gauge galvanized steel). A few years ago I worked on a system in Wisconsin, just north of Dubuque with just such material. The problem was that the copper and steel had gotten wet (condensation under glass!) and had ruined everything. Also, the steel was very slow to react to the sunlight (too thick). A better material would be copper foil. No chemical problems with moisture and thin copper will transfer the heat—quicker and more efficiently than steel.

Use of a flat black paint that will not boil off the copper absorber is a must, also. Using just any old flat black paint will slowly fog up the under side of the glazing and also radiate heat from the black surface of the absorber.

Thanks again for everything you have done for alternate energy. Your mag is making a big difference here in Iowa. Don't forget our annual energy expo in Iowa City on August 23 and 24 (see ad under I-RENEW in this issue). Tom Snyder, President, I-RENEW, 611 2nd Street South, Dyersville, IA, 319-875-8772

#### **To North Carolina HP Readers**

If you own a home with any type of photovoltaic application, you are invited to participate in a study being conducted by North Carolina A&T State University with assistance from the NC Solar Center. The study will survey owners to determine (1) details of each photovoltaic application, (2) requirements in the operation and maintenance of each system, (3) user evaluation of system performance and related household energy consumption patterns, and (4) general user satisfaction and usage factors. All responses will be handled confidentially; only group results will be reported. The purpose of the study is to document and provide information concerning photovoltaic applications in residences to assist consumers, as well as the PV market and industry in North Carolina.

If you are interested in participating or would like more information, please call by July 1, 1997. Carolyn S. Turner, Ph.D., Phone: 910-334-7692, FAX: 910-334-7674, E-mail: TURNERC@ATHENA.NCAT.EDU

#### **Why No Back Dated Issues?**

Guess I have to count myself among those who would prefer reminder notices in the mail separate from the "last issue" statement on the label. I could go on about traveling for work 3/4 of the time, overwhelming time demands reducing reading even such a great and informative magazine as Home Power to "as time permits", the difference between responding to bills or other vendor correspondence and tossing a magazine in the "to read" pile, etc. Any such argument/reason/excuse could be met with a call for more diligence by each subscriber, so it's basically a question of customer service and whether you're losing subscription revenue as a result.

Theory aside, I am writing with a more practical concern. I recently noticed that I had received my last issue (#55 at that time) and sent in my renewal. Since I realized my renewal request was late, I sent a note asking that my subscription be continued uninterrupted, as a reminder in case special handling was required. However, my renewal subscription started with issue #57 (rather than #56), and has my "last issue" as #62. The last issue being seven higher than before (#55) indicates that my subscription skipped a month rather than that I had actually received #56, but simply overlooked it.

Home Power is in many ways an unfolding story, with articles, columns and letters referring to previous issues, most frequently, the immediately preceding issue. So, in reading issue #57, I was lost whenever the frequent references to issue #56 popped up.

Now that I've missed issue #56, is it still possible to "back date" my renewal to #56, with a corresponding change of my "last issue" from #62 to #61? Or, do you feel I should be subject to the "back issue" ordering procedures (and expense!)?

Of course, I would prefer to receive issue #56 and consider it part of my ongoing subscription, so that is what I am requesting with this letter.

Please let me know your decision. To save you the effort of drafting a response, simply sending me issue #56 and reflecting the new "last issue" on my address label would be just great! Kevin Amaro, Penryn, California

*Hi Kevin, The reason why we haven't been able to "back date" only one issue was the mailing cost. Now, please bare with me here—this is kind of complicated and I'm no writer! The last time that I asked our "office of origin" post office no one knew how to send single issues via our publishers periodical (2nd class) class permit. This type of permit is only available to periodicals and requires audits and tons of paper work to get—but, allows a much cheaper rate than 1st class mail and moves through the mail stream faster than third class mail. Our mail service takes care of all the paper work/labels/presort/barcodes/etc. for the main bulk mailing of each issue, so I didn't have a clue. A single*

*issue of Home Power does not weigh enough to be mailed via the much cheaper bound printed matter rate, so we had to mail all single issues via 1st class @\$2.39 each.*

*We mail each issue the third week every other month. For example: The April/May HP#58 went in the mail the third week of March. Our mail service in Minnesota needs three to four days to process and print the labels and send the labels to our printer in Wisconsin. We closed the data base for issue #58 the second week of March. Any subscriptions after the data based was closed had to be held over until the next issue was sent. Your letter prompted me to ask about Periodicals Class "single issue" mailing. again. Success—since the last time I asked another publisher moved into town that knew how it was done! We can now honor the many "I missed the last issue" renewals. This only applies to the current "current" issue, so if you've missed more than one issue we will continue to mail those "Bound Printed Matter."*

*As a small gift for "reminding" me to check with the post office again we'll send you that missing copy of #56.*

*As for the renewal notices—check out the new subscription form starting in issue #58. There is now a box to check if you want us to send you a renewal notice—but only one!*

*Karen—the worst writer of the crew!*

**Tower Question to Mick Sagrillo**

Would you please explain to me why you installed Pat Preston's Bergey 850 on a TallTower so close to buildings, people and other precious objects (the PV's for example). I'm sure the placement of the tower was discussed. My rule is to never put a tower up close enough to hit anything valuable should it fail. There may have been good—(can there ever be any?)—reasons (land ownership?) but I would like to have had them recognized and discussed in such a prominent article: *Home Power* #58, pp 6-12. The photo on page 10, top right shows the tower to be about 15 feet from the corner of the garage.

I was the mechanical engineer for, and still work on, the NRG Systems Talltower designs. There are no labels on the tower but I'm just this side of positive it is one of our towers. (It's always possible there's a copy out there somewhere). These strong but slender and flexible towers are subject to failure in certain conditions such as, but not limited to, severe icing and the severing of a guy set by a snow plow or sleepy driver in the dark. S--- happens. Towers fall. Bergeys fall off towers onto roofs, obviously, since it had already happened once at this site. Lesson #1 should have been not to install wind machines where a structural failure can mean real catastrophe. Just curious.

P.S. I happen to have the manual for the Bergey 850 here. Just found it. On page 13 there is a list of DOs and

DON'Ts (which I wrote long ago. Mike Bergey based his tower manual on ours). Number four says "DO NOT erect the tower within 2 times the tower height of buildings, roads or walkways." I also note that there were people all over the place within the fall radius of the tower during the lift (on the garage roof—nowhere to run, even): photo, p10 top right. If something had happened!!!! Is there any way this can be fixed, the tower moved?

More than just curious. Paul Kenyon, Bridport, Vermont, e-mail: Paulkenyon@juno.com

*Paul, You've got some great questions here. First off, let me say that this type of article features an installation and is not necessarily meant to go into the hows and whys of decision making. That discussion is more often left to a technical article.*

*To address your concerns, Pat Preston, the owner, Johnny Weiss of Solar Energy International, and I discussed location of the tower in depth well before the tower was ordered, especially in light of the failure of the first installation. This is a low voltage system (24 VDC), and long wire runs are always a problem with low voltage wind systems. The further the tower is from the battery bank, the heavier the wire needs to be. Since the wire proceeds to the top of the tower, tower height must be included in the wire run length. At some point, wire cost becomes prohibitive in a wind installation. The decision is to always place the tower as close to the battery bank as is safely possible.*

*The key words here are "safely and possible". We were able to orient the guy wires so that the tower could come very close to the corner of the garage. As far as safety goes, I feel that that is a decision of the homeowner and installer. Having had considerable input in over seven hundred installations and visiting many more that that, I have a pretty good feeling as to what will work and what will not. Home built towers still make me shudder.*

*On the other hand, manufactured towers, such as NRGs TallTower, are engineered to stay up. My personal feeling is that warnings of "two times the tower height" are put there essentially to satisfy attorneys and the liability insurance industry, and are not necessarily founded in reality. If you are telling me, which I don't believe you are, that these towers will inevitably fall down, then why should any homeowner put one up? And why should any dealer sell one. After all, no one builds a garage then refuses to park in it for fear that it will fall down on their car.*

*Dealers and installers must have the same level of confidence in the products they sell, or they should not be in business. As such, I, as the dealer, along with the homeowner, having made the decision of where to place the tower, assume responsibility for the tower's location. That takes the manufacturer off the hook, as it should be. Yes "s--- happens," but that's why I carry liability*

insurance, just as Pat carries homeowner's insurance. My responsibility was to deliver a properly installed wind generator and tower. Pat's is maintenance of the system, including regular inspections of the tower and guy hardware.

*(By the way, these concerns seem to be limited to the United States. In Europe, for example, wind generators are often sited in public places, where people have ready access; parks, beaches, school yards. In the US, we site systems away from the public, then surround them with barbed wire fences peppered with threatening warnings. Maybe our adversarial litigious society here in the US has gone too far.!)*

*To answer your other concerns about icing and snow, Pat lives in the Colorado desert. There is no snow, or snow plows, or icing. She owns 40 acres around the house, so a "sleepy tractor driver or errant steer" in not a problem either. Another site with a different climate and set of circumstances would have warranted different considerations.*

*As to people being within the fall radius of the tower during its raising, once again, I commend you for your observance. This was a class for dealers and installers. I believe that students learn by doing, not by watching. The students were an integral part of the installation. Everyone had jobs to do that were critical to the raising of the tower. Safety was discussed prior to the raising, as was tower physics and the diameter of the fall zone. Everyone involved, including the person on the roof taking the pictures, identified two escape routes in the event of a failure during raising.*

*The raising was frequently stopped to discuss a particular aspect of the situation at hand. Students were instructed that any one of them could stop the raising at any time if they saw something they didn't understand, or that they felt was wrong. Idle conversation doesn't exist during a raising. By the way, the photo showing the tower going up with the Bergey mounted on it was actually the second raising. We raised the tower without the wind generator first, then plumbed the tower alone. Subsequently, the tower was lowered for reraising with the Bergey.*

*I hope this has addressed your concerns. I assure you that every precaution was taken when siting the tower, as well as, during the installation. I don't like paying the liability insurance industry any more than is absolutely necessary. Mick Sagrillo, e-mail: msagrillo@admin.itol.com*

### **Energy Efficiency in Germany**

I just returned from a trip to Germany where I attended the ISH show (International Sanitation and Heating Exposition). This show is in Frankfurt, Germany—a city of about 600,000 people.

The Exposition itself was interesting, being housed in a complex the size of which I had never seen—about ten

football fields—over two million square feet of floor space. Over 600 different companies from all over the world showed everything from plumbing to heating to energy saving devices. The latter was the theme for this whole show was energy and conservation. Out of which some interesting contrasts were presented between the US and the rest of the world. In short, we are not just energy hogs, but in comparison are extremely wasteful in our approaches to water, waste, and energy. These facts came to light during the trip which lasted seven days and where I stayed in a hotel in Wetzlar, Germany. The hotel itself was the first item of interest in construction and operation. There was not a standard light bulb in the place, and for that matter on the trip. Everything that I saw was low-voltage halogen, compact fluorescent, or low pressure sodium. Further, the toilet was so low flush that it only contained about 1.5 pints and flushed with added air pressure. They asked guests to reuse towels so as not to create as much wash, which saved water and made less pollution. All heating I saw was hydronic with radiators or fan coils, with small fans which used only about 15 watts, for heat from hot water. I asked and found out that the Hotel Mercure used natural gas for heat from hot water. The amount of gas used was equal to about 50 gallons of propane daily, for 60 rooms, food preparation and heating. The electrical usage was what floored me. This motel used about 86,400 watt-hours per day, or about 3,600 watts per hour—many all electric homes in the US use this amount energy.

At the Expo, the theme of the entire show was energy efficiency. There were roll-around air conditioning units which were rated for 1.25 amp service @ 240 vac and which seemed to have Danfoss compressors coupled to the chiller coils. These units would freeze you butt off on high. There were many displays with new advanced solar flat-plate collector units, direct coupled to the hot water tank and which had a unique method for drain-back and refill to prevent freezing. One of these was in operation outside the building and was producing 194° F water at 10 in the morning. Frankfurt is about 200 feet above sea level and has the solar stats and climate of the Northeast US. The day was partly overcast. This is but a small sampling of the goodies at the show. There were commercial and residential gray-water recycling systems, special rain-water storage, and filtration tanks, etc.

I asked many of the companies why these things were not available in the US. The answer was always the same three things. First, the US actively prevents these companies from doing business here. Secondly, they were not sure of the market, since US official studies available to them showed no market for these products, thus they assumed no one over here cared about efficiency or conservation. Third, the main reason was two-fold—the regulations in the US would not allow them to distribute these products, mainly because of UL, whom they characterized as the American Mafia in the

way they treat new products—all they want is money. As another part of this, there is our legal system. They see us over here as being liable to sue anyone for anything at the drop of a hat and that we have more lawyers than any other profession. Part of this is true—in the phonebook for Frankfurt, a city of 600,000 people, there were two pages of attorneys or legal counsels—about 150 in all. I asked our guide about this and he said it is considered poor taste to sue someone, and is socially not acceptable. It actually says more about the person suing than the person being sued—that they did not have the ability to work out their own problems. They have a variety of arbitration companies, some sponsored by the government, which will help you work out your difficulties for a small fee. The outcome is legally binding. I'm not saying that we should emulate the Europeans in every way, but it makes you think. Maybe we could take a few lessons on how we conduct business, where our values are, and how we perceive the world. Mainly because we are no longer the big kid on the block with the big stick. More importantly, we all share the same problems. The world is growing smaller every day, everyone needing food, water, energy, and shelter, and really folks, there is only a finite amount available. It can last a day, a month or a lifetime depending on how we use it. Our focus needs to shift from litigation and protecting the public from imagined problems to dealing with new products and technology fairly—allowing these new products to develop before subjecting them to the uneven and unfair tests and unenlightened regulators. Wm. VonBrethorst, Planetary Systems, PO Box 9876, Jackson, WY 83001, phone & fax 307-734-8947

#### **A Web Solar Class**

I was reading your web page and just wanted you to know about a solar class offered by Mohave Community College (<http://www.mohave.cc.az.us/>) over the net. I'm currently taking the course. It's a three credit course (BTR 120.) It's awesome to know that I can take a class on solar, even when I live all the way in North Idaho. I just thought you would like to know alternative energies are reaching out just a little further by offering these kind of classes on the net. Wolf Paw (Edward Padilla), e-mail: padilla@dmi.net

#### **LED Candela**

A question on the Jade Mountain solar powered LED light What are the watts on the PV module and what's in it for low voltage disconnect? What is the lumen or candela of the LED light? Fred Lester, Springfield, MO  
*Hello, Fred. The PV module makes about 1 Watt of power in full sunlight. The low voltage disconnect is a small surface mount chip with four legs, obviously an integrated circuit designed for the job, but without any numbers I could see. Also on the LVD printed circuit board are several programming resistors.*

*I have no maker's data on photometric measurement such as lumens or candela. There is no greater measurement swamp than photometry. Add to this the fact that LEDs don't make white light and measurements like lumens and candelas become super vague. Bottom line is everyone here can read fine text within 18 inches (0.5 m) of the lamp. Richard Perez*

#### **A Sailboat Home**

I love your magazine and find the articles informative and very interesting. I received the Solar I CD ROM in the mail this week and have stayed up till 3 am every night since, trying to absorb the information contained in it. I'm sure this CD will educate me for years to come. I can't wait for the Solar II CD ROM.

Besides being trapped in front of my computer reading your CD ROM, I am in the design/save my money stages of an AE project. The goal is to build a long range cruising trimaran which uses a permanent magnet electric motor, battery bank, and PV panels to provide locomotion when there is no wind. While sailing I will be able to run the PM motor as a generator off the prop and thus help charge the batteries. Other equipment will be a small wind generator, a well built solar oven and a few solar salt water distillers. I hope to be able to solar motor at three knots in windless/sunny days and be able to motor for short distances at four knots with the aid of the battery bank. An electric powered range of 20 miles is acceptable for me in that the primary locomotion should be the wind. Right now I'm looking for a solidly built 33 foot trimaran without a motor. Anyone know of a good deal? My current sailboat and home, Blue Otter, has an outboard motor, which has kindled my interest in a solar-powered boat. One of my favorite moments is when I have just raised the sails and I turn off the noisy, smelly, polluting, \*%@!%^\* outboard motor on the stern—suddenly everything is quiet as Blue Otter cuts effortlessly through the water with the help of the wind—all tension from the boat is removed and a large silly grin starts to develop on my face. I can't help it, I love sailing—but hate engines. I think my outboard senses my loathing. Last summer on a two month cruise in British Columbia I spent three weeks of my time and half my meager budget in a small port waiting for motor parts. After this the motor still wasn't agreeable. I was very close to making an anchor out of the thing. This outboard lasted only 600 noisy and polluting hours (probably a good thing). I hope the electric motor in my future solar sailor will last 50 times that long, and provide quite, pollution-free service.

I want to thank you at Home Power again for your magazine. Reading about people who are already powering their lives with earth friendly energy helps to nurture my own dreams. In this way you and the others who live with sustainable energy are changing the planet. Not only are you helping the planet with your own use of sustainable energy, but your actions trickle down

to others like me—watering the seeds of an idea—helping our dream to grow and become a healthy and robust reality. Brandon Davis, Seattle, Washington  
*Hello, Brandon. I'm glad you like the Solar1 CD-ROM. We've almost got Solar2 done and expect to debut it at the 1997 Midwest Renewable Energy Fair. I've dreamed of a cruising Tri for years. Lots of deck space for modules. Consider using the new triple junction PVs made by UniSolar. They will tolerate the partial shadings, which inevitably happen on a sail boat, without excessive power loss. Richard Perez*

### **Solar cooking in Kenya**

I am a Peace Corp Volunteer stationed in Kenya. My primary work involves facilitating the construction of ferro-cement water tanks and plastic waste pipe gutters for various self-help groups within the Kikuyu Tribe. My secondary projects revolve around various appropriate technology oriented projects—solar cooking, solar shower, solar food drier, wind power, and fuel efficient wood stoves.

I've just received my first two issues of your magazine and I'm happy to have found many of these areas featured. I anticipate that this is just the beginning of our correspondence together, as I'm likely to continue with the appropriate technology field, and you're likely to continue providing useful information to me.

I've developed quite a nice solar cooker which is cheap (about \$4 for materials to build one), effective and easy to construct. If you'd like the plans, I will soon finish a small revision to my manual and send it to you. We manufacture them here in my village. They sell for \$8. They are growing in popularity and will be introduced in large quantities to refugee camps here in Kenya..Just let me know and I'll send a manual and photos or negatives of it to use if you think you may feature it in any way.

The reason I have written to you is for you to reference me to someone able to assist me with very simple plans for a home-built windmill for charging 12 Volt batteries. I've built one using three 5 foot long aerodynamic wings. We had a problem balancing it. It easily reaches 400 rpm. A local crafts person and I are considering building one which works at lower rpm's to avoid shaking our tower to bits.

At my place we have extremely strong, ridge-top winds, so something simple like the Windstream could work for us, but we want to reach a wider market, areas with little wind. We are considering a design having lots of power, a large wing area exposed to the wind, like an old water pump style.

Most of all, we need to have an easy to build automatic speed regulator. Presently I'm considering one which tilts back and is kept facing the wind using tension (also like the Windstream).

Please, can you direct me to someone(s) who may

already have tried and true plans. We hope to create a small income generating business here in my village. And yes, usually we have electricity and a welder in the village center.

Lastly, are there any companies who might be willing to provide some financial assistance for the tools and materials we may require for start up? My pockets are pinched between many small projects and these pockets are too shallow anyhow.

Thanks for your guidance. Todd R. Harris, PO Box 975, Kikuyu, Kenya, East Africa

*Hello, Todd. Most modern wind turbine which generate electricity rotate at high speed (well over 300 rpm). This makes the wind genny's shaft power more compatible with electric generators (which like high rpm for a variety of esoteric techie reasons). I tend to discourage homebrew of wind gennys. It's much more difficult than most folks imagine. Obtaining high efficiency and longevity is a job for a pro with a high tolerance machine shop and lotsa patience.*

*Karen asked Kim at Lake Michigan Wind & Sun and she says that there are several good books on and sets of plans for homebrew wind electric generators available from Hugh Piggott, Scoraig, Dundonnell, Ross shire, IV23 2RE, Scotland, UK. Good luck! Richard Perez*

### **Island Power**

Greetings from the Island of Roatan (30 miles north from the coast of the Republic of Honduras). For a period of around 20 years, we have been making our own power. Unfortunately, the first ten years was pretty much dependent upon diesel generators and no one knows the problems, maintenance, and just plain nuisance, much better than we do! For instance, carrying fuel in an open motorized canoe, in five gallon "jerry cans", for 30 miles in open ocean along with various other supplies. Parts were ordered from the "States" and with any kind of luck, would arrive within six months!

Our first hot water heater was a 45 gallon drum painted black.

Around 1987, I was working at a local shrimp packing plant which owned several "company" boats and noticed that an inordinate number of large, heavy-duty 8 Volt batteries were being thrown aside. In testing these batteries, I found that the majority of them were 1) either still good, or 2) had one bad cell, with the other three cells in good shape. I carted them home and started our first all night electricity, by first connecting up the good cells until I had enough batteries to give me 12 Volts, and then charging them when it was necessary to run the genset. Voila, 12 Volt car bullet reading lamps, 12 Volt fluorescent for the bathroom and we thought we had moved to Metropolis.

Somewhere in this period we had heard of photovoltaic panels, but of course, rumor had it that these were very

expensive (never did the “rumorers” have a firm price) and these were a new scientific invention that probably didn’t work anyway. Consequently, our thoughts turned to wind. We had several cruising sailboats visiting us regularly and we obtained a consensus that wind generators made by Hamilton Ferris were of first class quality and able to withstand a marine environment. Not knowing about checking out a site for wind variation, average velocity, etc., we purchased what I believe to be the first fixed site generator from Mr. Farris. At this point I would like to say that the Ferris generator was a good one; the problem was just plain ignorance on our part. The wind that felt like it was always there, turned out to be a nightmare of swirling eddies (due to high hills that obstructed normal Trade Wind flow) and proved to be worthless at our location. A couple of years later, a friend of ours made a trip stateside and concluded that photovoltaics were indeed practical in our area, and not as expensive as previously thought. As a result, we bought four Siemens M-55s from him and proceeded to charge the “shrimp boat batteries” with the panels. Now, if we could only eliminate the odorous, noisy genset. Well, add a Heart EMS-1800 inverter, Bobier NDR-30 controller and four Trojan L-16s and that booger WAS eliminated! (well, except for four hours a week to run the 1 1/2 hp, 220 v submersible water pump, that pumped water to a gravity tank).

Reason for the full conversion? A local power plant (diesel gensets) had been built to supply the power for the whole Island—cost to hook up—\$6,000 and the privilege of paying \$0.70 US per KWH! Since then we have added: four more Siemens M55s; two Solec 70s; four more Trojan L-16s; a Solar Jack submersible pump w/controller; 25 Arco M-51s, which we happened across at a give-away price; a new Heliotope CC-120E controller (from the good folks at Backwoods Solar) to tame all those amps; and a home-built active solar water heater (temp=136°F, home-made anti-thermosyphon valve, cost less than \$200 including a Grunfos recirculating pump and special Omron timer, less labor).

We run a computer 24 hours daily (monitor off at night), all kitchen appliances (we have a jam & jelly business) including microwave, toaster, toaster-oven, grinders, food processors, ice cream maker w/compressor, two(!) automatic washers, three ceiling fans and three desk fans, 14” TV with VCR and satellite dish and associated equipment, stereos, Vacuum cleaner, two rain water pumps, all power tools, iron (sometimes as much as eight hours a week—Lisa has a batik clothing business), and enough lights to light a 3200 sq. ft. home, including security lights. We have not been without power for ONE minute since installation. The local power company is out for an average of twelve days per year, and we haven’t had a major storm yet! Around 1 1/2 years ago we somehow got a copy of *Home Power* magazine and life

has never been the same! Although we do not subscribe, (mainly due to mail problems) we did buy the CD-ROM #1 and we would like to reserve a copy of #2 as soon as it comes out. Needless to say, we are convinced that solar is the ONLY way to go, especially here in the near-tropics where Mother Nature graces us with abundant sunshine—at 8:00 am this morning there was 50 Amps of energy pouring into our batteries. We have more power that we can possibly use.

A note on the Trojan L-16s—as stated we started with four and added four more approximately two years later. I had only equalized the first four one time approximately six months after installation, and was very unhappy with the high gassing and heat build-up during the equalizing cycle, and therefore did not equalize again. We did not notice any problems with the batteries by not equalizing and just today I checked the cells again and there is no more than 0.03 Volts difference in any of the cells! I put this down to the following: constant monitoring of the battery liquid level; GOOD charge controllers; 85–90°F year-round ambient air temperature; good battery box; clean connections with stainless steel bolts and copper bus bars; and although a lot of appliances are used, I have never seen the batteries discharged lower than 12.1 Volts.

We have just installed a Solargizer high frequency battery maintenance system as an experiment for a local electrical contractor who does limited solar installations. We tried it on three discarded 12 V vehicle batteries first, with very impressive results. We are also going to install HydroCaps (thanks to *Home Power* ads and tests) to help eliminate terminal corrosion and minimize water consumption. Distilled water is impossible to obtain here. The past week we installed a solar system for a local church—two Arco M 51s, one 120 Amp-hour battery, an 8 Amp controller (again from the folks at Backwoods Solar), a 600 watt inverter and several circline fluorescent bulbs for the night services at the church—all works well!

Now for a technical question: Some time ago, we were given a wind generator that had been taken off a sailboat. It was only the alternator with the blades attached. There are no markings, brand name, etc. on the outside (nor inside) of the unit. It has an alternator housing approximately 6” in diameter and approximately 3” thick, made of cast aluminum. There are approximately 14 blades resembling a fan, and is approximately 24” in diameter. The blades are made of green molded plastic, and on the inside of the blades, where they fasten to the hub, are the words “made in Denmark.” I measured the output of the alternator and found it to be producing up to 40 volts ac depending on the wind strength. I proceeded to make a box which contained a full-wave bridge rectifier and a 16V–1000mf filter capacitor across the output leads. This arrangement

gave me DC Volts which again varies up to 25 VDC depending on wind speed. The problem is—the alternator does not put out much more than 0.25 Amps even in a stiff breeze of approximately 18 knots.

1) Do you know what brand this wind generator is, and if so how I could contact the manufacturer?

2) Is there anything I can do to increase the current, even at the sacrifice of some voltage?

I am assuming that this unit was made to solely trickle-charge batteries on board a sail boat and was not intended for land use, nor to apply a very high charge, but if you could suggest a way to increase the efficiency of this unit, I would be very happy.

Keep up the fine magazine and please let me know when the new CD-ROM is available. Brian and Lisa Blancher, C/O Jackson Shipping, 5353 W Tyson Ave, Tampa, FL 33611

*Hello, Brian and Lisa. I can tell you nothing about this particular wind genny, I believe that at least one of readers will help. How about it, Readers? Your approach of full wave rectification followed by filtration is the way to go. Simply run whatever DC power is produced into your battery. Consider building a small solar still to make distilled water for your batteries. It's easy and very effective. Richard Perez*

**Free of Charge**

I just received my 1st copy of your magazine & wished I had it years ago. Of all the books, mags, etc. I have read, yours has already entered my top five list. Thanks for the good work.

We have a small community in central New Mexico and have been here for two years. We are looking for new members and will assist, free of charge, anyone wanting to "get out" and become totally self-sufficient.

We have built two small houses out of tires, two sheds and one house out of free shipping pallets. Our next house is going to be built underground out of a few tires with an old satellite dish roof. I can't wait to start this one since I used to install dishes in Florida.

We use PVs for all of our electricity needs and cannot praise them enough. It's wonderful to use free electricity, that works as efficiently as they do. Our advise to anyone that is thinking about PVs is to simplify your life first. It's absolutely amazing the junk you can do without and it actually enhances your being to do without this stuff.

We also grow our own food, cook it with the sun, heat water with the sun, etc. One of our goals is to slow down our pollution, etc. of the planet and to use recycled garbage that already exists. So far, we are doing just that.

If anyone out there would like to be pen pals or visit us, we welcome you. Mike Jones & Joy, VOH, PO Box 364, Bosque, NM 87006



**Enjoy the Peace & Quiet of Country Living**

**3 Bedroom / 1.5 bath solar-powered home**, 1670 sq ft + full basement, 2 car garage, 15'x15' deck with large screened porch, 10'x20' sunroom, 10'x20' summer kitchen. Passive solar heat, wood/gas backup. All appliances included (gas stove/oven, Sunfrost RF-16 fridge/freezer). Basement office with built-in desk/shelves. Hard-wood floors, sauna, observation deck, solar hot water. Many built-ins. Bright & open design. Freshly painted. Fenced 1/2 acre organic garden. On school bus route. 15 acres (10 treed, 5 open). 24 solar panels, 2KW wind generator, new batteries, all electricals. Ready to go! Owned by non-smoker! Age approx. 12 years. Many Extras! \$64,500.

**Dan Lepinski, RT1 Box 268A, Exeland, WI 54835  
(715) 943-2525 (7PM-10PM CST please)**

**Waking Up  
the Northland to  
Renewable Energy &  
Sustainable Living!**

**Bringing the finest in technology, equipment, and  
knowledge to the northern midwest.**

Solarex & Kyocera photovoltaic modules  
Trace & Heart inverters  
controllers, meters & more!

**SOLAR**  
**Great Northern Solar**

Route 1 Box 71, Port Wing, WI 54865 (715) 774-3374

# Writing for **Home Power** Magazine

**H**ome Power is a user's technical journal. We specialize in hands-on, practical information about small scale, renewable energy systems. We try to present technical material in an easy to understand and easy to use format. Here are some guidelines for getting your RE experiences printed in *Home Power*.

## **Informational Content**

Please include all the details! Be specific! We are more interested in ispecific information than in general information. Write from your direct experience—*Home Power* is hands-on! Articles must be detailed enough so that our readers can actually use the information.

## **Article Style and Length**

*Home Power* articles can be between 350 and 5,000 words. Length depends what you have to say. Say it in as few words as possible. We prefer simple declarative sentences. Sentences which are short (less than fifteen words) and to the point. We like the generous use of Sub-Headings to organize the information. We highly recommend writing from within an outline. Check out articles printed in *Home Power*. After you've studied a few, you will get the feeling of our style. System articles must contain a schematic showing all wiring, a load table, and a cost table. Please send a double spaced, typewritten copy if possible. If not, please print.

## **Editing**

We reserve the right to edit all articles for accuracy, length, and basic English. We will try to do the minimum editing possible. You can help by keeping your sentences short and simple. We get over three times more articles submitted than we can print. The most useful, specific, and organized get published first.

## **Photographs**

We can work from any photographic color or B/W, print, slide, or negative. We prefer 4 inch by 6 inch color prints which have no fingerprints or scratches. Do not write on the back of your photographs. Please provide a caption for each photo.

## **Line Art**

We can work from your camera-ready art. We can scan your art into our computers, or redraw it via computer. We usually redraw art from the author's rough sketches. If you wish to submit, via computer file, a schematic or other line art, please call us via telephone.

## **Got a Computer?**

We use Macintosh computers to make *Home Power*. We would like your article's text on 3.5 inch computer floppy diskette. This not only saves time, but also reduces typos. Please also send a hardcopy printout of your article in case the electronic copy doesn't work. Please format all word processor files in "TEXT" format. We can also read text files on 3.5 inch IBM disks (800 KB, or 1.4 MB). Please format the IBM word processor files as ASCII TEXT.

You can send your article via modem to either the HPBBS at 707-822-8640 or via Internet as an enclosed TEXT file(s). HPBBS address is: Richard Perez

Internet email address is:  
richard.perez@homepower.org

It is wise to call, via voice, ahead of electronic file submission. This is particularly true concerning graphics files. There are many, many ducks and they all need to be in a row....

## **Want your material returned?**

Please include a stamped, self-addressed, return envelope, or box. Otherwise your material will not be returned.

## **Copyrighting**

If you request it, then we will copyright your work in your name. Otherwise we will copyright the information in *Home Power's* name. The copyright on your material is yours for the asking.

## **Got any questions?**

Give us a call. This saves everyone's time.

## **Access**

*Home Power* Magazine, PO Box 520, Ashland, OR 97520 USA • 916-475-3179 • Internet email via:  
richard.perez@homepower.org





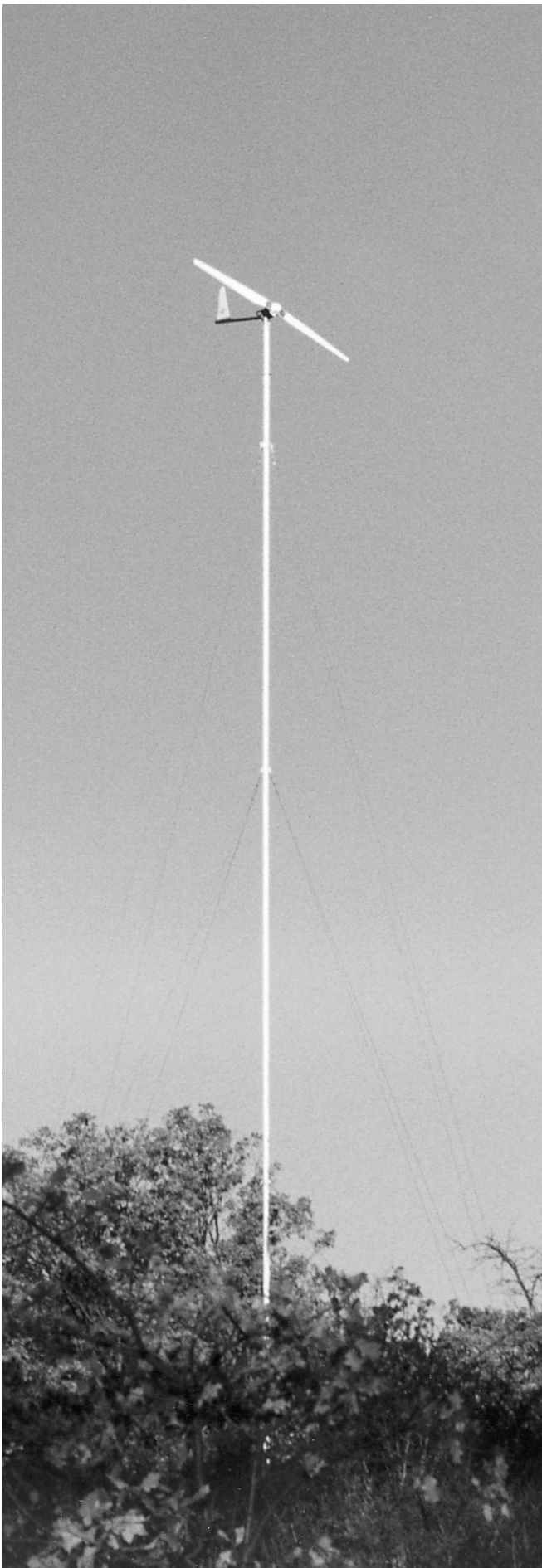

### MINI 12/8

- Low Cost •
- Feature Packed •
- High Performance •

8 amp PWM  
charge controllers

Optimised for  
smaller systems

For all battery types  
& chemistries.

Great for RVs, boats,  
remote homes...

Available world wide.  
Call your local IPP dealer



### B. Z. Products, Inc.

7614 Marion Ct., St. Louis, MO 63143, USA

tel: 314-644-2490, fax 314-644-6121

e-mail: frank9966@inlink.com



Ed Rannberg, a much-beloved fixture in the electric vehicle community, died April 16, 1997. He was featured in an article in Home Power #58 with his land speed record streamliner.

Ed, proprietor of Eyeball Engineering in Riverside, California, had been an electric vehicle builder from the early days in the mid 1960's. He had a special love for various kinds of electric racing, on two wheels and four. He was well known for his meticulous vehicles, his snow-white handlebar mustache, and his robust good humor and warmth—not necessarily in that order.

He is survived by his wife Geri and his son and racing partner Randy, as well as his daughter Sandy, two sisters, eight grandchildren, and countless friends. His speed record team is contemplating taking his streamliner for a low-speed run at the salt flats this summer in his memory.

He will be greatly missed.

# Ozonal Notes

Richard Perez

©1997 Richard Perez

First off, I have never received as much mail and feedback from *Home Power* readers as I have from last issue's Ozonal Notes. I am buried in e-mail, snail mail, FAXs, and phone calls. I had been letting this info stay in house—thinking that you were not interested in the innards of *Home Power*. Well, here it comes again. I am overjoyed to be able to share our thoughts about HP with you.

### Home Power without the dead trees....

Many thanks to all of you who participated in our first experimental electronic distribution of *Home Power Magazine* #58 via the Internet. The good news is that everyone who got it got the whole issue in living color, just like it is printed in the magazine. The bad news is that only about half of those we e-mailed the issue to actually got it. The problem is internet vendors and ISPs. We attempted to e-mail an attached 5 MB Adobe Acrobat Portable Document Format (PDF) file. Many ISPs limited the incoming file size to 1 MB or less. Here our electronic issue just bounced back as undeliverable. Almost everyone who received the PDF reported being able to view and print it. We are happy with our choice of the Acrobat PDF and we will be sticking to it.

Many recipients of the electronic issue of HP#58, said that while it was great, it could not replace the printed-on-paper issue. I agree. It's difficult to view a PDF when the only source of light is a kerosene lamp. I think the electronic edition of *Home Power* is best used internationally by folks who already have electricity and computers. Internationally, our distribution is vague. It sometimes takes over four months for an issue to arrive. Sometimes they don't arrive at all. Electronic distribution would be secure and ultra fast.

Download times for the electronic issue HP#58 mostly varied from one hour to 2.5 hours. George Patterson, connected to a light pipe at the other HP, won the speed record at 5 minutes 37 seconds. Since the photographs in the electronic edition are heavy compressed, no one complained about page draw times in Acrobat.

I learned much from this experimental electronic distribution via the Internet. I learned that the infrastructure is fragile and that we asked it to do more than it was capable of. Not all Internet servers (ISPs) can handle the large file. And thinking of efficiency, why

write this large file to your server at all? Why not let you check into our web page and download the electronic issue whenever you want?

### Home Power—The Next Electronic Edition

If you want to join in the next experiment in electronic distribution, then use your web browser to go to:

<http://www.homepower.com/download.htm>

If your web browser has Adobe Acrobat as a plug-in, you will automatically view the file with your browser. We do not recommend this, but rather suggest you save the file to your disk then read it offline using Acrobat Reader. If you do not yet have the Acrobat Reader for your machine, then use the link on our web page to obtain it.

The electronic edition is large—over 5 MB, so make sure you have space on your hard drive. Expect the download time (and keep us posted on this) to be about one or two hours, so make sure that the phone is free. Please let me know if there are any problems. Thanks for helping us out!

### Reading Your Mailing Label versus Renewal Notices

Here the mail ran about 2/3 for checking that mailing label, and 1/3 for separately mailed renewal notices. We are offering a renewal notice to anyone who wants one. Just check the box on your subscription form (see the insert between pages 80 and 81 of this issue). While most readers urged us to charge a buck or so extra for this renewal notice, we've decided that the book keeping is not worth it and we'll send it out for free. Your conscience is your guide....

### Solar 2 CD-ROM

While surfing through the waves of demented digital detail required for this issue, we have been hard at work on our next CD-ROM—Solar 2.

Solar 2 will have *Home Power*, from issue #1 to issue #42, in Acrobat PDF. The data will look just like it did when printed in the magazine (well, almost). Some of the early issues were done in a page layout program that didn't handle fonts well and there are some text flow differences. But everything is there. Since we didn't start digital photos until HP#37, all of the analog photos we published pre-HP#37 are missing. From HP#37 on, all our editorial photos are digital and will appear in the PDF.

While the electronic edition we ship via the Internet is squashed to the max to save space, the electronic edition on the CD-ROM is uncompressed and rich in photographic detail. You can zoom in on photos at 4X in Acrobat and read the fine print on equipment, see wiring details, or the hairs on someone's nose. The

photos actually contain greater resolution than those printed in the magazine. If your machine gets slow because of the hi-res photos, then turn off the "Display Large Images" option in your Acrobat Reader.

Many thanks to Don Kulha, our CD-ROM Guru, for making Solar 2 more useful. He not only PDFed most of it, but also did a swell user interface which indexes the contents. That's right, you can now actually find the info you want quickly and easily.

We will be debuting Solar 2 at this year's Midwest Renewable Fair and we will have it for sale shortly thereafter. Price will be the same as Solar 1—\$29 (\$3 extra for international shipping).

### Advertising Ghetos

Well, this sure kicked up a flurry of response! Everyone likes articles running uninterrupted by advertising. Folks say they read the ads anyway and appreciate having the editorial information delivered directly. For more reader feedback on this, please see the Letters section in this issue.

### Well, what's next?

Hey, beats me most of the time. You'd think that after ten years of publishing this magazine, I'd have it down. Well, I don't. I am continually amazed and astounded by the happenings around me. I'm just hanging on to the surfboard and trying to maybe see beyond the next wave.

Technologies are changing. RE is becoming utility intertied. PV cells are being made more efficiently (check out the new UniSolar triple junction which uses about 1/500 the amount of purified silicon). Maybe America's favorite form of roofing will be changing to photovoltaics. Maybe America's utilities are willing to accept our solar energy. Hey, who knows? Not me.

### Come to the Fair!

See you at this year Midwest Renewable Energy Fair on June 20–22 in Amherst, Wisconsin. We have much to talk about. I'll be delivering two workshops each day (batteries and inverters). Most of the HP Crew is going. In a fit of major airline disgust, we are all driving in a behemoth motor home and doing an "issue on the road" along the way. Shades of "On the Bus in the Sixties!"

### Access



Author: Richard Perez, c/o Home Power, PO Box 520, Ashland, OR 97520

voice: 916-475-3179 • FAX: 916-475-0836

Internet e-mail: richard.perez@homepower.org

Web: www.homepower.com

Written using solar power at the Funky Mountain Institute, Agate Flat, Oregon  
42° 01' 02" north 122° 23' 19" west.





- DESIGNERS & BUILDERS OF HIGH-PERFORMANCE HOUSING
- DEALERS AND INSTALLERS OF MASONRY STOVES

HEAT KIT, ALBIE CORE,  
& ENVIROTECH STOVES

**GIMME SHELTER**

PO BOX 176 • AMHERST, WI 54406  
715-677-4289

## COMMUNICATION

C. CRANE

## COMPANY

AM/FM • SHORTWAVE • ANTENNAS • BATTERIES • MORE

**BAYGEN FREEPLAY® RADIO**

No batteries required. A full wind takes about a minute and will power the radio for half an hour or more. Good audio. AM, FM, and SW bands. 14" x 10" x 5.5" 7Lbs. Price#BAY.....\$119.95

•Solar power adapter for Baygen... \$10.00 (with Baygen purchase only)



Dealer inquiries invited

**SATISFACTION GUARANTEED**  
Call for a free catalog

E-Mail: CCRANECO@AOL.COM

# 1-800-522-TUNE

# Q&A

## 12 Volts & Lighting

I have spent the last ten years living and working in Saudi Arabia. As such I am rather ignorant of many aspects of the subject matter of this letter. I am not ignorant, however, of the need to develop and utilize alternate forms of energy—sometime ago we committed to utilize AE in our new home. Your excellent publication Home Power reaffirms this commitment.

In planning our new house we will make it 100% independent of the electric utility: to be—completely off-grid—to use your parlance. We plan to use solar and wind to produce electricity for our electrical needs.

In our planning I have assembled a fairly full “alternative energy” library, thanks in large part to your publication. Thanks also to my neighbor, Bruce Johnson, who successfully made his escape from the magnetic tentacles of the “grid” a decade or more ago and who is an enlightened contributor to your fine publication. Indeed, Bruce effected my “discovery” of Home Power.

In my planning, I have evolved numerous questions for which I have not been able to glean answers to from my available sources. Consequently I come to Home Power, the All-Knowing Oracle of AE, for answers.

### 1. Low Voltage DC Circuit Selection

We are having difficulty choosing the voltage for the second circuit. It appears to us that the majority of low-voltage DC equipment and appliances are 12 Volt and thus it would be most practical to go 12 Volt (see question #2 below). And yet we see the availability of 24 and 48 Volt equipment seemingly on the increase. There must be a demonstrable electric advantage of these higher voltages although I do not know what that advantage is.

What is your opinion of this important and basic question on which we must make, what I see as, an extremely important and far-reaching decision very soon?

In such a dual voltage circuit system, to avoid mistakenly plugging 12 Volt gadgets into the 110 volt circuit, it would seem judicious to utilize a completely different “plugging” system for the 12 Volt circuit. Would you suggest perhaps the circular plug and jack system currently in vogue for most 12 Volt adaptors?

### 2. 12 Volt Transformers

It is my observation that a great many pieces of electrical equipment operate on 12 Volt DC current but, are designed and sold to function on conventional 110 volts ac systems through a transformer.

Assuming that we elect to install both 110 volt ac and 12 Volt DC circuits, it would seem electrically inefficient, and

thus electrically wasteful, to plug such equipment into 110 volts ac with the energy then being converted to 12 Volt DC. Rather, it would appear practical to simply eliminate the converters and plug such 12 Volt DC apparatus directly into the 12 Volt circuit. However, I notice that the 12 Volt transformers sometimes (usually?) requires varying amperage requirements.

Would a single 12 Volt DC circuit set at a “standard” amperage (whatever that might be) be a practical solution to this problem? I presume then that the odd amperage situations would simply have to go through the 120 volt ac to 12 Volt DC transformer conversion? What do you suggest?

### 3. Illumination and Lighting

As will be seen from the following questions, we are confused as to selection of specific types of lighting to accomplish our illuminating objectives.

Standard incandescent bulbs are inexpensive to purchase but generally seem to be short lived, except perhaps for “long life bulbs” which I have always suspected are really advertising gimmicks. I have bought such bulbs in the past, methodically dated each bulb, but then, just as methodically, I seem, to forget about them. To really determine their efficiency someone should, of course, run some controlled tests but I am not set up to do so. Perhaps you are aware of such tests?

Further, incandescent bulbs do produce a great deal of heat, counterproductive relative to interior climate control in summer and distinctly destructive to “exhibit” items (photographs, artifacts, etc.) when used inside display cases.

In the limited reading I have done on the subject of the efficiency and/or science of illumination I think that we probably should be considering lumens produced per watt of energy used. Further, the old bugaboo of cost of fixtures (including bulbs and tubes) must be carefully considered.

I will study these aspects in more detail but, for practical considerations, I need to resolve the matter of how to utilize electrical energy produced by solar and wind power with respect to equipment available.

I do not want to reinvent the wheel in this matter but I will do my homework. However, I need some practical guidance which I hope you can and will provide.

### 4. Halogen Lamps

I have read (from the manufacturers) that halogen lamps provide light more closely similar to daylight than other light sources (excluding, I suppose, the distinctive temperatures of light produced by photographic bulbs and flash equipment).

Further, I have read (again, from the manufacturers) that halogen lamps are twice as efficient as standard incandescent bulbs. Also that halogen lamps last twice as long. I personally have several halogen lamp appliances

and over the short term, at least, have found them quite satisfactory.

My question: can halogen lamps be converted, in a practical manner, to utilize 12 Volt DC current, and if so and most important, how to do it?

#### 5. "Spot" Lamps

Although we plan to utilize considerable fluorescent lighting for general illumination, we prefer a more "target intensive" illumination for esthetic purposes ("spot lighting") in many areas. Halogen illumination would appear to be ideal to accomplish this purpose but, it seems to produce a great deal of heat and I wonder if there is a more energy efficient form of illumination available, other than the HID referred to below?

#### 6. Fluorescent Lamps

As with other nominally 110 volt ac fixtures which actually utilize small 12 Volt fluorescent lamps and which operate from a transformer—can I simply dissect out the transformer and safely plug the fixture directly into the 12 Volt circuit?

I understand that "compact fluorescent lamps" are supposed to be highly efficient but are they different electrically from what I guess are "standard" fluorescent lamps? Are they more or less efficient?

At the risk of complicating this question further, we frequently use fluorescent lighting of wave lengths which enhance vital plant growth, such as "GrowLux" lamps and I wonder if these are available for 12 Volt applications or can be made to operate on 12 Volt systems?

#### 7. High Intensity Discharge Lamps (HID)

I understand that such lamps have an efficiency of over 12 lumens per watt, can generate up to 140 lumens per watt, and last many times longer than standard filament lamps. I suppose they utilize a gas but, am ignorant as to the actual mechanics. Can HID lamps be used on 12 Volts and how to do so in practical application?

#### 8. Outdoor Lighting

From a perusal of outdoor lighting technology available, I see that high-pressure sodium lamps offer efficiency of up to 140 lumens per watt but, I personally feel that the yellowish color that I associate with this type illumination is unnatural and therefore, for me at least, objectionable; metal halide lamps offer up to 115 lumens per watt and the quality is more natural (i.e., closer to daylight); mercury vapor is another option but I have no data on its efficiency or its color characteristics.

There is also "quartz" lighting about which I know nothing except that there seems too much of it now on the market and at rather low purchase prices.

Can you give me any guidance on the above light sources so far as alternative energy installations are concerned?

Your assistance in helping us resolve these questions will

be of tremendous value as we complete our home plans. I do enjoy researching problems such as these. I enjoy the actual application of workable solutions to such problems. I have also always made it a practice to share with others the knowledge and experience gained.

If the questions which I have raised here are of interest, then I would be delighted to submit the results of my efforts for publication in your splendid magazine.

From now on I will be residing in the States most of the time, completing plans for our new home and then constructing it. Lawrence Curtis, Oklahoma City, Oklahoma

*Hello Lawrence, let's see if I can answer your questions.*

*Battery voltage depends on system size, distance to RE sources, and a host of other system and site specific parameters. Consider using 24 VDC as your battery voltage.*

*In days past, reliable inverters were a dream and we used low voltage where ever possible. If the appliance didn't come with a car cigar lighter plug, then we didn't buy it. In 1983, I even tried to convert my first Macintosh computer to run on 12 VDC (and failed). The advent of reliable and efficient inverters has changed everything. I used to think that we lost efficiency by using the inverter, but careful measurement has shown us that this is only rarely true. For example, if power lost in low voltage wiring is compared with inverter inefficiency we find them about equal.*

*And then we come to actually buying the low voltage (mostly 12 VDC) appliance. I remember the 12 VDC blenders. They had two speeds (off or on), lasted about a year, and cost about \$75. They had to be special ordered by mail. Contrast this to a 117 vac blender—dozens of speeds, lasts for years, is available everywhere, and cost less than \$30. The scene is much the same for all low voltage appliances. They are more expensive, less well made, and are not easily available. Access to mainstream appliances is one big reason to use an inverter.*

*Although many appliances come with low voltage power supplies, there are problems with putting many of these appliances directly on battery power. For example, we fooled around with several telephone answering machines and 12 VDC. Most of the time, powering the answering machine directly from the system battery created ground contention problems (the phone company grounds positive and the home systems ground negative). Using the power supply which came with the appliance gives the appliance DC isolation from the battery. This is important in communications electronics (radio and TV), telephone electronics (FAX, answering machine, cordless phones) computers, and computer printers. The factory supplied power supply produces a constant voltage while the battery's voltage is constantly changing with its state of charge. Some appliances can find battery voltage either*

too high or too low at certain battery states of charge. And there are always some appliances that just plain don't come in a low voltage version. For example, all the computers, and computer peripherals in our office.

Our home and office used to have 12 VDC lighting exclusively. By the way, all fluorescent lighting runs on high voltage. The 12 VDC fluorescents each contain a micro inverter which makes high voltage to fire the fluorescent tube. Now we power all the lighting on 117 vac supplied by a sine wave inverter. It's cheaper, more efficient, and performance (i.e. light quality and intensity) is superior. We are using 117 vac compact fluorescent lighting almost everywhere. We still use incandescents in areas where the light is switched on and off frequently and only run for short periods of time (closets, stairwells, pantries, entrance lights, and battery rooms). We especially like the Osram 11 watt compact fluorescents which come with reflectors. Over the cook stove we use halogen lighting powered by the inverter. The heat and duty cycle over the cook stove rapidly killed compact fluorescents. I find that the high pressure sodium and mercury vapor lights produce such a poor quality of light that I don't care how efficient they are. Their light is just plain ugly.

Currently the only major home appliance we still power with 12 VDC is our RF-19 Sun Frost refrigerator/freezer. The Sun Frost is over five years old and if I had it to do all over again I would buy the 117 vac model.

If you add up all the additional expense of low voltage wiring and low voltage appliances in a medium to large home system, then it costs more than buying an inverter.

Bottom line here is buy a good sine wave inverter, wire your house just like normal, and use efficient 117 vac appliances. It's easier and cheaper.  
Richard Perez

### Battery Rotation

Two quick questions: I notice the last battery on the positive end of my bank always seems to be the first to die. Is this a system/charger problem or just the load on the final cell? Is rotating batteries a good idea? Also, does anyone make a 12 Volt home stereo (not car stereo)? It seems such a waste to run my inverter when the stereo is transforming the voltage back again. Thanks and keep the good stuff coming. Edward Brown, Eugene, Oregon

Hello, Edward. I have also noticed that the outside cells (either major positive or major negative) tend to fail first. I have no idea why. How about it readers, anyone know why the outside sells of the battery fail first? I am sure that rotating cells (or even batteries) within a battery can reduce this problem. Rotate and rearrange those cells regularly.

All 12 VDC stereos are designed for automotive use. We bought our last 12 VDC stereo in 1978 and it ran until last year when it croaked. It was so old I couldn't even get parts for it anymore. We now use a 117 vac stereo and power it from a sine wave inverter. We leave one of our sine wave inverters (a 1 kW Exeltech) up and running all the time. It powers our comm gear (answering machine and two FAXs) 24 hours a day, so its up and running anyway. On most medium to large systems, the inverter is awake all the time anyway, so you might as well use it. You are correct about efficiency, our new 117 vac stereo consumes about 1/3 more power than the car unit it replaced. But then our old car stereo didn't have two tape decks, a three CD changer, or power as many speakers. When it comes to features and flexibility, the 117 vac stereos smoke the car models. For just one example, we can now run stereo audio from the VCR into the main sound system—makes movies better than downtown! Richard Perez



## Helio-Gram

June / July 1997

### Introducing FPC-15

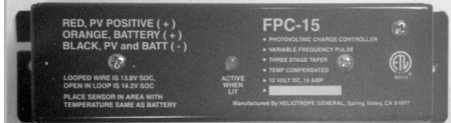

- At less than one inch in height the latest charge controller from Heliotrope General is the FPC-15.
- FPC means "Flat Pack Controller" and the 15 means 15 amps.
- From the originator of PWM (Pulse Width Modulated) controllers, the FPC-15 is also a pulse type. The three stages of this series type charging are bulk, pulse, and float.
- The FPC-15 is available as a 12 Volt model and the customer can choose a state of charge of 13.8 or 14.2 Volts.
- As with all Heliotrope General charge controllers, the FPC-15 is standard with external temperature compensation. (Automobile manufacturers would not dare make a car with our temperature compensation on their charging circuit....Don't build a PV system without this necessity.)
- Perhaps one of the nicest things about the FPC-15 is it's price. This bare bones model is priced at \$79.00 and is available from leading alternate energy dealers and distributors.

The name means reliability.

Heliotrope General  
3733 Kenora Dr.  
Spring Valley, CA  
91977  
Fax (619) 460-9211  
(800) 552-8838  
(619) 460-3930

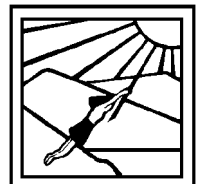



## Home Power MicroAds



Rates: 10¢ per CHARACTER, include spaces & punctuation. \$15 minimum per insertion. Please send check with ad. Your cancelled check is your receipt.

Help us prevent fraud! Home Power MicroAds from individuals must supply serial number(s) for equipment being sold. Businesses must supply a published phone number(s) and a physical address. If at all possible, please pay for your ad via personal or business check or credit card.

While Home Power is doing everything we can to prevent fraud, we can assume no responsibility for items being sold.

**USED WIND GENERATORS, Towers, inverters, & Water Pumpers:** 80 systems in stock, 1500 Watts to 10kW. We repair & make replacement parts, blades & governors for most wind systems, pre-REA to present models, specializing in old Jacobs wind generators. We build tilt-up towers and tower-top adaptors for the Whisper Wind Generators. Best prices on Bergey, NEO, Whisper, & Windseeker. Plus we pay shipping to the lower 48. Call with your needs or write to Lake Michigan Wind & Sun, 3971 E Bluebird Rd, Forestville, WI 54213, 414-837-2267, Fax 414-837-7523

**PURE CASTILE & VEGETARIAN SOAPS.** Handmade in an AE environment. We also have hard to find natural bath & body care products. FREE catalog: SIMMONS HANDCRAFTS 42295 AE, Hwy 36, Bridgeville, CA 95526

**HYDROELECTRIC SYSTEMS:** Pelton and Crossflow designs, either complete turbines or complete systems. Assistance in site evaluation and equipment selection. Sizes from 100 watts to 5 megawatts. Manufacturing home and commercial size turbines since 1976. Send for a free brochure. Canyon Industries Inc., P.O. Box 574 HP, Deming, WA 98244, 360-592-5552.

**LOW WATTAGE KIRBY'S (110 VAC)** Rebuilt with 6 mth guarantee. As reviewed in HP#23 Home & Heart & HP#32 Things That Work. 4 Amp/\$175, tools/\$25 UPS/\$25. SANDERSON'S 20295 Panoche Rd., Pacines, CA 95043 or (408) 628-3362

XXXXXXXXXX USED SOLAR MODULES XXXXXXXXXXXXX  
XXXXXXXXXXXXXXXX 16-2000 - \$165.00 XXXXXXXXXXXXXXX  
XXXXXXXXXX ARCO M51 — \$185 XXXXXXXXXXXXXXX  
900+ Amp Hour phone batteries, cheaper than golf cart batteries — \$60 per cell. PWM Charge Controller's 8 amp to 32 amp, \$45-\$99. Cruising Equipment new E-Meter \$179. Trace inverter 2512 \$1095. 1000 watt sine wave UPS 48V \$200, new 14 cu ft gas refrigerator \$1795, new & used ni-cads from AAA to 250 AH. Will match or beat anyone's prices on equipment. Call or write for free flyer. Craig, 10192 Choicena, Hesperia CA 92345, 619-949-0505. Trade-in's welcome. M/C VISA Discover accepted

**AVAILABLE NOW FROM THE MIDWEST RENEWABLE ENERGY ASSOCIATION:** Renewable Energy/Efficiency Directory. A great networking tool listing users, providers, networkers, educators and "do-it-yourselfers" in the RE fields. Send \$5.00 (includes postage and handling) to: MREA, POB 249, Amherst, WI 54406.

**LED ILLUMINATION:** Ultra High Efficiency Light Emitting Diodes provide 10 times the battery life of incandescents. Flashlight \$10.95 (includes batteries). LED arrays, 5 diode unit 11.95, 10 diode unit \$17.95, 20 diode unit \$31.95. Larger arrays can be made on request. Red or yellow LEDs available. Units have essentially unlimited life. Free information. Noctilume, P.O. Box 7800, Fox Hills, CA 90233 (310) 967-4719

**YOUR ALASKAN SOLAR EXPERTS!** Complete source for Alaskan alternative power. ABS Alaskan, 2130 Van Horn Road, Fairbanks, AK 99701 907/452-2002, AK 800/478-7145

**VERMONT SOLAR ENGINEERING** — Over 15 years electronics & solar experience—Expert design & consultation, professional installation, sales & support, repair & upgrades — PV, Hydro, Wind & Domestic Hot Water. Do-It-Yourselfers welcome—price list available (sorry, no catalog at this time). Custom systems, kits & components at most attractive prices. Call Kirk toll-free, 1-800-286-1252, 802-863-1202(local), 863-7908(fax). PO Box 697, Burlington, VT 05402.

**CEILING FANS:** The largest selection of DC Powered (12 & 24VDC) ceiling fans anywhere in the U.S. From traditional to modern, classical to custom design. For brochure and list of dealers send SASE to R.C.H., 2173 Rocky Crk Rd, Colville, WA 99114. Dealer inquiries welcome FAX 509-685-0535

**SOLAR HOT WATER SYSTEM Kits:** Thermosyphon Design—Simple & Reliable— NO pump and controller—Perfect for Remote Homes— Complete Kit including piping, valves, New Stainless Steel 80 gal. Tank, Used 40 sq. ft. copper collector— only \$800 + freight & crating F.O.B. Escondido. CA (800) 564-0403

**START YOUR OWN TECHNICAL VENTURE!** Don Lancaster's newly updated INCREDIBLE SECRET MONEY MACHINE II tells how. We now have autographed copies of the Guru's underground classic for \$18.50, Synergetics Press, Box 809-HP, Thatcher, AZ 85552. (520) 428-4073, VISA/MC.

**INTERESTED IN INTENTIONAL COMMUNITY?** Communities magazine offers complete, updated listings of intentional communities not found in the Communities Directory. Practical information about forming/joining community — alternative buildings & structures; getting off the grid; # legal, financial & land options. Plus Eco-villages, Cohousing, decision-making, conflict resolution, successful communities, children in community, research findings on community living. Quarterly. \$18/yr, \$5/sample. Rt. 1. Box 169-HP, Louisa, VA 23093. (703) 894-5126.

**WIND/SOLAR/HYDRO ELECTRIC SYSTEMS.** Propane refrigerators, ranges, lights & heaters. Diesel battery charger, Best buys on Inverters & Sun Frost refrigerators. DC Compact Lights, Pumps, Low cost DC motors, Grain mills, Tankless water heaters, Composting & Low flush toilets, Fence chargers, Solar cookers & stills, Books, Shortwave radios & much more in \$4 Catalog. Windmill Water & Hand pump Catalog \$5. Food Catalog \$3. KANSAS WIND POWER, Dept. HP97, 13569 214th Road, Holton, KS 66436 "Since 1975" 913-364-4407 Discount Prices!

**EARTH-SHELTERED HOMES** This definitive manual by noted authority Loren Impson features detailed building instructions for the amazingly affordable and practical Ferro-Cement Dome Home. Only \$15 from Sun Life HC 63 box 309, Mount Ida AR 71957

**LOW-REVVING BRUSHLESS Generator** with 3700 gauss magnets—detailed how to instructions. Reviewed in HP #32/P86. For a free brochure, contact Al Forbes (+649-818-8967, Fax +649-818-8890, URL: <http://www.onekw.co.nz/>) PO Box 3919, Auckland, New Zealand.

**APROVECHO RESEARCH CENTER** offers 3 month training sessions in appropriate technology, sustainable forestry and organic gardening. Classes begin June, September, January (1 month in Mexico), March. Daily classes 8:30-5:30. Cost is \$500.00 per month, includes room, board. For more info: 80574 Hazelton Rd., Cottage Grove, OR 97424. (503)942-8198

**FREE PROPERTY LIST** for mountain land, some with creek or river frontage in beautiful Scott Valley, Northern California just 15 minutes west of Yreka off I-5. 5 to 320 acre parcels, perfect area for retirement or country lifestyle. Call Scott Valley Real Estate (916) 468-2252.

**PORTABLE LUMBER Mills.** Introductory special 2895. Capacity, 26" Diameter, 12'6" Length. Extensions and trailer packages available. Band saw type. Wizard Engineering, P.O. Box 15, Sheep Ranch, CA 95250 (209) 728-3976.

USED, SURPLUS AND DEMO Solar Equipment for sale at reduced prices. Inverters, Generators, Solar panels, Battery chargers and more. Discount prices on new equipment as well. Call or write us today for a free list of products, technical assistance or a free product or installation quote. 1-800-364-9941 Suntek, 10629 138th Ave SE, Rainer, WA 98576

ORPHANAGE NEEDS 1 or 2 PV module lighting system. Praying for donations and help designing system. We know nothing, need help. John (618) 993-8357; in Uganda (256) 483-22193, Fax (256) 483-22636.

ELECTRIC POWER YOUR BICYCLE. Henthorn Regenerative Electric Auto. Simple Homemade Hydrogen. Plans catalog \$1. DWFrench, POB 2010(AEHP), Sparks, NV 89432

VERMONT DEALER. Come and visit my new well stocked and informative showroom in our off-grid PV, and microhydro powered neighborhood. Helping do-it-yourselfers with free professional design advice for 10 yrs. Sales of new and used equipment, installations and service. Free educational workshops (see Happenings). SALE! Solarex modules, TriMetric battery meter \$145; shunt \$20; Trojan L-16 \$145, T-105 \$64, batteries F.O.B., CT. FREE with battery purchase IP&L Deep Cycle Battery Instructions. Used TRACE inverters 2524SB \$700, 2524SB DVM ACTC \$900. Westerfield AC mag ballasts for 2 pin CF's \$4.50, specify 13W, or 7/9W. Surplus Cruising Equipment Meters CHEAP, call. Large supply of wire and cable. Overstocked and used controllers and meters. Independent Power & Light, RR 1 Box 3054, Hyde Park, Vermont 05655 call or fax David Palumbo 802-888-7194. E-mail: indenppower@aol.com No catalog requests please. Please call for appointment before visiting.

20 KW JACOBS wind generator for utility interconnect system on 100 foot freestanding tower; crated & ready to ship: New Equipment with original factory warranty: \$18,500 + shipping. 120 foot tower available for an additional \$2500. Lake Michigan Wind & Sun (414) 837-2267.

FOR SALE: Photocopied reprints of Home Power issues 1-10 available. All proceeds will be donated to IRENEW. Call 815-469-5334 or e-mail Jeff\_Green@msn.com. Sold only in sets of 1 thru 10 for \$30 which includes shipping in most cases.

DIRECT TO YOU SALE!!!! (no pickups on these items) Dometic (Serval) 7.7 cu. ft. propane fridge \$995; Trojan L-16, \$149; T-105, \$62; all items freight extra. VT Solar 1-800-286-1252

STOP POISONING YOUR FAMILY, pets, livestock, home and our fragile environment with the Harsh Chemical laden products you are using!!! YOU Now have the POWER to DO something about it! Start using these Natural, Earth Friendly, Biodegradable and Totally NonToxic products Today! We have an Exciting assortment of Personal care products with pure Tea Tree Oil, a natural antiseptic, pain reliever and healing agent. Skin care products to protect your skin naturally. Health & Nutrition products that provide you with the right nutritional tools for Your body. Concentrated Home Care products to take care of Your everyday cleaning tasks + more! These products really work! The products and their ingredients are Never tested on Earth's Precious Animals. We really enjoy these products and so will You! If we all do a little, together, we can do ALOT! Help us make a Big difference for our Fragile Planet! A portion of our Families profits as Independent Associates goes toward Renewable Energy Education! "Keep the Dream!!!" Distributors always welcome. Free catalogue & Distributor Info. The Silver & Bonnie Niewiadomski Family Homestead Farm, 102 River Drive, Plover, WI 54467, 715-344-0924

SUN SHIRTS....100% Organic cotton T shirts, with unique hand painted sun designs. For list of styles Send self addressed stamped envelope to: SS PO Box 14, Saxapahaw NC 27340.

THE NEW NEMO SUBMERSIBLE Well Pump features a Flojet pump head/motor unit enclosed in a rubber gasketed all metal case. DC or AC, 230' max. lift, 2.5 max. G.P.M. Complete Units or Case Kits. Unbeatable Prices. Call or Fax 508-627-1319 for Free Info Sheets. Dealers invited.

BAHAMAS, ABACO. Beautiful 2 bed. 2 bath solar home for sale. Dock, garage, workshop and more. \$230,000. For info. Fax: 242/366-2250 or write "Treehouse" PO Box AB20491, Marsh Harbour, Abaco. Bahamas.

SELLING WATER PUMPING Windmills Send \$5.00 for catalog. Muller Industries Incorporated 1102 W 21st St, Yankton, S.D. 57078 605-665-1924

ACME DIESELS from \$1,499. Modules: M-55 \$325, Pro4JF \$399, VLX-53 \$295. T-105 \$59, L-16 \$147.50. Danby LPG refrigerator \$895. Send \$6 for all 3 catalogs. Electrifying Solar, Box 681394HP Houston, TX 77268.

EDTA RESTORES SULFATED Batteries. EDTA tetrasodium salt, info, catalog, \$12/lb plus \$3.50 ship & handle. Trailhead Supply 325 E. 1165 N. Orem, UT 84057

POWER VENT— BATTERY BOX Ventilator & Back Draft Damper. Positively vent battery gases to the outside and keep batteries warmer by stopping cold back drafts. Uses 2 watts, only when batteries are charging. Requires a voltage sensitive switch for control, standard in Trace SW inverters. Specify 12 or 24 volt. \$74.95 + \$6 S & H. For more details, contact Cone Construction, POB 52, Salida, CO 81201. 719-530-0718

CHINA IMPERIAL DIESEL Generator Sets 6-40 KW. Send for your Free Brochures. County Line Engine-H, 1063 St Rt 545, Ashland, Ohio 44805

COLORADO ROCKIES HOME is only minutes to resort community of Salida. Access to Nat'l Forest from this rugged 40 acres with unsurpassed views. New construction, 2092', 3 bdrm, 2 bth, 2 car garage. PV system with generator back up. Free video available. \$189,000. SkiCo Realty. Call Kathleen Nelson 719-539-4782.

LIKE NEW 6VOLT 9 AHR Gell Cell Batteries w/fuse + plug \$14 each while supply lasts, 12v 20 watt Halogen Puck Lights \$15 each, shipped ups free, Replacement Wind Blades, New and Used Wind Mills & Parts, New Jacobs 20KW w/100' tower \$18,500 + freight, Service, Installation and Consulting Anywhere Since 1982 Catalog \$4, Bannertown Power & Light PO Box 92 Mayfield, NY 12117 phone/fax (518) 661-5445, E-Mail: windsmith@computech-net.net, Web Page: computech/alternative energy.net

15 KW JACOBS WIND Generator Bought 3 years ago 14'6" blades updated inverter 80' Rohn tower grid interconnect is up and running \$10,000 1-508-839-9547

CONSUMER SOLAR PRODUCTS Your ultimate source for hard-to-find solar gadgets: Panels, Radios, Garden and landscape lights, Mosquito Guard, Ni-Cd Battery Charger, Plant Turner, Lanterns, Bicycle Lights, Flashlights, Hats, plus more at wholesale and retail prices. For details, visit our site at: <http://www.global-merchants.com/home/solars.htm> E-Mail: solar@global-merchants.com Phone: (909) 593-7278 Fax: (909) 596-1783

I AM A SOLAR WHOLESALER looking for retailers to carry my solar electronic and hobby goods. Phone # (916) 486-4373. Please leave message.

ZOMEWORKS IS LOOKING FOR an experienced salesperson with a PV or electrical background. Must be bright, hardworking, and honest. Work entails PV system sales, design and support. Excellent work atmosphere with innovative people. Compensation includes base plus commission and benefits. Write to David Hughes c/o Zomeworks POB 25805, Albuquerque, NM 87125

ORGANICALLY GROWN BULK instant soup mixes. Delicious and Nutritious. Cheap, fast meals. <http://www.solomonsmines.com> or [soups@solomonsmines.com](mailto:soups@solomonsmines.com)



GAUSS METERS. 1mg to 10 mg at 50/60 hz. \$30 while supplies last. Dr. Gauss, the EMF detective will measure power lines, appliances, computers. My electric coop magazine (Rural Living) refused to advertise this product! CSL Marketing 14501-C Lee Jackson Hwy Chantilly, VA 20151. (703)631-4949 or Toll Free (800)203-8697

ADIRONDACK MOUNTAINS 25 Acres, View of Mountains, 6 acre pond, lg. wood lot, good wind, PV and Micro Hydro site. Unfinished earth sheltered home, dug well, 750' drive, 30 min. Saratoga, 3 hours to NYC, 35 minutes to Gore Mt., sub-dividable, \$72,000, (518) 661-5756.

20 ACRES SOUTHERN OREGON very remote solar hydro powered log home, greenhouse, sauna, 2200 ft. elev., 2 yr round creeks, fruit trees fenced gardens, timber, \$149,000 541-660-0353

EVAPORATIVE AIR Conditioner 12 Volt—Fits up to 14" by 14" Roof Vent. New, in box. \$275.00 Tel 607-638-5474

PV MODULES FOR SALE, Siemens perfect condition. Some never used. Half price. Call James (707) 528-4287

JACOBS WIND GENERATOR 2500 W 32 V reconditioned, new style governor & blades with 45' tower 4 leg self supporting \$2995.00 Tom Hill (610) 367-7210 evenings

JACOBS WIND ELECTRIC Plants Best-of-the-best Original Model 45's(1800W) and Model 60(2800W), late 1940's production, very complete—Call eves for details (313)561-2707

UPSTATE NEW YORK—Three Bedroom one and half Bath Home, with sixty foot Hip Roof Barn, Garage. Should Make Good Solar Power, Very Private, near "I 88" \$65,000. 607-638-5474

FOR SALE AEROLITE Windmill parts gearbox complete good shaft generator control box with spare contactor and Pinson Energy top assembly with blades 412-537-6068

TRACE 4024-\$2000/ DR 1524-\$700/ Solarex MSX10L-\$75/ Siemens M110-\$500/ Solavolt 75w Panel-\$379/ All used. Call (502)889-0624 Visa/MC.

SANTA FE, NM. Remote land—inspiring 360 mountain views, peaceful and sunny. 20 acres or more \$2,000/acre. Terms. Broker (505) 438-7330

120V WIND SYSTEM—\$6500 obo-Jacobs generator: 100' guyed tower: 20 batteries-Trojan L16: inverters-Exeltech SI-500 & Best 2500w. Will sell tower separately. Danny Young Westfield, VT 05874 802-744-6122

BATTERIES 4 SALE: 24 cells rated 1270 amp-hr, arranged in two 24V strings, \$2500 each string, call 360-398-9196, pickup Calistoga, CA.

FOR SALE: 80' ROHN SSV Tower. Used, in good condition. On ground. Also, Jacobs 1800 watt generator. Rebuilt, needs some parts. (218) 732-4979.

ANANDA APT2-300 Power Center with SPM 2000 meter—only used for demos, still under warranty. Power Center has DC breakers for 2 PV arrays, wind input & diversion load and other loads. SPM 2000 checks for amps, volts, watts, amp hours and watt hours from 2 inputs. \$1,500 new, now \$600, firm. Jeff Albrecht 360-650-0707.

60 AND 120 WATT "GLOBAL" Propane thermal electric generators, 12 or 24 VDC, \$ 300 and \$400, Dave 504-271-5349.

HYDRO-ELECTRIC Generator Plant 9 KW incl. cross-flow turbine, generator, electronic controls, transformer (220-440v). Needs connection to utility co. \$7000. 700 ft. of 12" alum. pipe available at \$4 per foot. 1-541-847-5448 Monroe, OR.

SALE SYNCHRONOUS Inverter built for North Wind Power HR-2, 2.5 KW 120 VDC wind generator. Works, needs fine tuning. No reasonable offer refused. Peter Romans, RD 3 Box 72, Barton, VT 05822. 802-755-6184

INSTANT HOT WATER Heater. Paloma model 1#PH-12MDPAGA New in box \$400.00 Bob Clark Lebanon, MO 65536 417-532-5636

FOR SALE: TRACE U2624SB, DVM inverter with wall bracket and 5 ft 2/0 battery cables, \$1100.00. Square D fused disconnect switch #H 364, 200 amp 600 volt, with 1 each 200 & 125 amp fuses, \$125.00. Shipping extra. Call Dave @ 206-851-2208

END CHEMICAL DUMPING From Your Washing Machine! Negative ion charged globe stays in washer, gets clothes as clean as detergent. Lasts 1,500+ loads and costs only \$75. Really Works! Money back guarantee! Physics solution to a chemistry problem (Distributor inquiries welcome) (541) 482-4454 or FreeseNet@aol.com

MACHINE WORK WANTED: small shop looking for work. Experienced in stainless, plastics, prototypes. Paladin Machine, 3832 Gates Ford Rd., Kershaw, SC 29067 ph/fax 803-475-7542.

N. CALIFORNIA. 160 ACRES, 1600 Sq. Ft. Home, solar, seasonal creek., pond, barn Sac. \$185K Terms. (916) 528-2712 Ev.

M51 PV PANELS, 35 Watts. 1-5 panels@\$140 ea+shipping; 5 or more panels@\$120 ea.+shipping; All 40 panels@\$100 ea.+shipping. 717-530-8282 after 7 PM Eastern time.

VERY LOW PRICES Solar Electric & Thermal Equip. Panels-Inverters, Charge regulators, wind generators-pumps-controls Please Call (415) 479-1737 or write to 6 Cresta Cir. #7, San Rafael, CA 94903

MUST SELL: Spectacular Real Goods Demonstration Home 2200 sq ft rammed earth home on 40 fenced acres in high desert near Bisbee, AZ. Passive solar design and full active solar system, Air 303 wind generator, SunFrost fridge, 3 bedrooms; 2 baths w/clawfoot tubs, 14' X 24' kitchen, tile floors, water catchment and well, garden w/fruit trees, 4 outdoor patios, incredible views of 6 mountain ranges, and more. \$215,000 Call Sloane and Danielle Bouchever @ 1-800-310-8574

HOW TO MAKE TONS Of Money From Home Even If You Live Out In The Boonies!! I will send you a Free copy of my Report that will show you how! Write today to: Leapfrog Dept. A806 Box 140 Tres Piedras, MN 87577

WHY ARE YOU Using a 120 Volt AC generator to charge your 12 volt battery? The GennyDeeCee makes 12/24 volt DC, w/out the 'middleman' (battery charger). Max output:100+ amps. At 75 amps fuel consumption is only .3 gal/hr. Introductory price: \$1285.00-UPS. See our display ad this issue. Free Info: Feather River Solar Electric, 4291 Nelson, Taylorsville, CA 95983. 916-284-1041

ECOMALL <http://www.ecomall.com>: renewable energy resources, daily eco news & articles, eco companies/products, vegetarian restaurants, activism & links, eco chat, business to business, national solar database. To advertise or for more info, please call 212-535-1876 e-mail: [ecomall@ecomall.com](mailto:ecomall@ecomall.com)

Wind generator: 12.5kW Jacobs completely rebuilt, blades 2 years old. Very good condition. 100Ft tower, newer inverter. \$11,000 319-556-4765, ask for Tom.

++BEST PRICES ON Batteries From Canada++  
+ Lowest Prices on the best PV equipment +  
\*\* Check us out: [www.SolarPowerStore.com](http://www.SolarPowerStore.com) \*\*  
\*\* Tel: 613-591-8639 Fax: 800-663-4Sun \*\*

SEEKING TO BUY: Mother Earth New—certain old issues Nos. 1 thru 93 (can I photocopy if you don't want to sell?) Reba (510) 233-7411 or (415) 983-7273

CAN'T PERK? FAIL Septic system? Bio-microBic's on-site state-of-the-art waste water treatment has the solution. No maintenance, no filters, environmentally clean. Call for brochure (412) 767-9926

BARELY USED M51s \$175! New Trace 2512 SB \$1095 delivered! New NiFe cells .40 AH; used .10 AH. Good used SolarKing 4X8 collectors \$195. VMB 1755 Coon Rd Aspers PA 17304 717-677-6721



# The Home Power Index:

*A (more or less) complete listing of all articles appearing in previous issues of Home Power*

Listed alphabetically by subject: first number is issue number-second number is page number

## Air conditioning

architecture, cool homes in arid climates, 40-24  
cool towers, evaporative cooling in arid climates, 41-38

## Alternative fuels

see "Hydrogen", "Methane", "Vegetable Oil", "Wood gasification"

## Alternators

basics, how they work, 20-10  
book reviews, The Homebuilt Dynamo, 32-86  
Homebrew, 12 VDC engine/generator w/ field controller, 2-23  
Homebrew, 12 VDC engine/generator w/field controller, updated, 42-28  
Homebrew, 24 Volt Mark VI, 22-73  
wind, generators, rewinding, 19-24

## Ammeters

see "Instrumentation, ammeters"

## Ampere-hour meters

see "Instrumentation, ampere-hour meters"

## Appliances

Asko dish washer, Home & Heart, 52-94  
Asko dish washer, part 2, Home & Heart, 53-78  
Bread Machine, Home & Heart, 58-90  
Electric heater , Thermal Art (TtW!), 54-71  
Load analysis, for system design, 58-38  
Phantom loads, Homebrew, detecting & eliminating , 55-36  
UL listings, appliances, system components, etc., 56-82

## Architecture

air collector, passive batch water heater, methane gas, 17-19  
air conditioning, cool homes in arid climates, 40-24  
Alternative building techniques, Home & Heart, 54-89  
Ariesun, solar powered house, 11-32  
batteries, building a clean, safe, warm, battery enclosure, 41-70  
book reviews, Adobe Journal magazine (letters), 43-100  
book reviews, design, Box Beam Sourcebook, 43-86  
book reviews, Resource Efficient Housing: Directory, 26-77  
book reviews, Shelter (home design), 18-49  
book reviews, The Hydroponic Hothouse (greenhouse), 28-76  
computers, IBM daylighting simulator software (TtW!), 29-68  
earth berm, concrete dome, 29-22  
efficiency, specs, mass, insulation, sources, Gimme Shelter, 46-37  
greenhouse, PV powered ventilation, 34-55  
mud rooms, Home & Heart, 55-92  
passive solar, basics, 11-34  
passive solar, radiant barriers, basics, 28-43  
passive Solar, sun room add-on, Sexton, 53-16  
passive solar, sunspace, trombe wall, radiant floor heat, direct gain, 32-28  
solar space heating, glass and glazing choices, 30-26  
SolarWind home, hexagon, 19-40  
straw bale, basics, overview, examples, sources, 46-44  
straw bale, in MN (photos, letter), 47-101  
straw bale, w/PV: 408 Wp, 12 V L-A, 35-62  
vapor barriers, specs for efficient home, sources, 46-37

## Ask NREL

efficiency, conventional power plants, RE, 45-62  
energy, amount in sunlight, world consumption, 41-36  
photovoltaics, breakthrough in low-cost efficient PV, 40-98  
photovoltaics, differences in PV technologies, 39-84  
photovoltaics, energy payback time of cell manufacture, 43-73  
photovoltaics, Why are pv modules blue?, 38-88  
wind, resource across the US, map, table and references, 44-30

## Back to the Basics

alternative, renewable, sustainable energy, 28-67  
moving to the country, 26-47

## Batteries

AA, brands tested/compared, 41-89  
AA, NiCd, recharging w/small PV, 36-78  
alkaline, operating tips, titration, 34-45  
alkaline, operating/testing tips, 34-44  
basics/historical, The advent of the sealed nickel cadmium cell, 52-34  
care & feeding, , 58-66  
chargers, charging with generators (Q&A), 43-107  
chargers, constant current, 23-69  
chargers, Heliotrope HC-75 (TtW!), 17-38  
chargers, Homebrew, constant current, 21-82  
chargers, Homebrew, constant current, efficient, 44-54  
Chargers, Homebrew, for small NiCd, Linn, 53-34  
chargers, Homebrew, NiCd pulsar PWM, 30-54  
chargers, Homebrew, simple NiCd, 23-71  
chargers, military surplus (TtW!), 41-66

## Batteries continued

chargers, with gas generator, 3-32  
Code Corner, safety, National Electrical Code, 40-94  
Code Corner, UL listed flexible battery cables, National Electrical Code, 41-84  
comparison, cost, lead-acids vs NiCd, 16-24  
comparison, of technologies, 35-54  
comparison, table, acid vs. alkaline, 17-35  
education, and PV, loads (teaching plan, part 2) , 15-5  
education, workshops, MREA, 47-74  
electric vehicles, fueling techniques, 36-57  
electric vehicles, overview, 35-50  
electric vehicles, placement & containment, 36-52  
Electric vehicles, Tech Talk, diagnosing battery condition, 57-105  
enclosures, design of a battery room, 33-42  
enclosures, Homebrew, clean/safe/warm, 41-70  
enclosures, Sailer system, 768 Wp, 6 V L-A, 42-6  
enclosures, ventilation, 6-31  
EV, Charging and Maintenance, 48-60  
Homebrew, 12 or 24 Volt portapower, 24-70  
Homebrew, Charger for AA Ni-Cd cells, 48-46  
instrumentation, Homebrew, high/low voltage alarm, 39-62  
instrumentation, Homebrew, LED bargraph voltmeter, 10-26  
lead-acid, basics, overview, equalizing, EDTA treatment for sulfation, 47-30  
lead-acid, basics, terms, tips, 9-27  
lead-acid, basics, terms, tips, tables, 1-25  
lead-acid, EDTA reconditioning, how to, 20-23  
lead-acid, EDTA reconditioning, preliminary results, 21-36  
lead-acid, equalizing charge (Q&A), 44-90  
lead-acid, gel cells, description of, 25-46  
lead-acid, internal resistance in, 3-34  
lead-acid, state of charge vs voltage at 34°F & 78°F (charts), 9-25  
lead-acid, state of charge vs voltage for 12 V & 24 V (charts), 7-25  
lead-acid, state of charge vs voltage, 36-66  
maintenance, diagnosing sick cells, 28-36  
maintenance, gassing, 19-50  
maintenance, Hydrocaps battery tops (TtW!), 11-37  
maintenance, neutralizing spills (letters), 42-106  
maintenance, treating sick cells, 29-44  
NiCd, chargers, Homebrew, wall cube replacement, 26-72  
NiCd, equalizing charge (Q&A), 43-108  
NiCd, pocket plate, care and feeding, 15-19  
NiCd, pocket plate, chemistry, types, State of Charge vs voltage, 12-16  
NiCd, pocket plate, evaluating used, 25-72  
NiCd, pocket plate, reconditioned (TtW!), 13-17  
NiCd, pocket plate, testing and reconditioning, 15-23  
NiCd, pocket plate, voltage regulation, 26-69  
NiCd, sintered plate, basics, description of, charging and discharging, 4-14  
NiCd, sintered plate, charging for radio, 33-68  
NiCd, sintered plate, charging small NiCd, 19-18  
NiCd, sintered plate, charging using pulses (homebrew), 5-27  
NiCd, sintered plate, charging using solar (teaching plan, part 1), 16-14  
NiCd, sintered plate, sidebar, Sunshine for All, 36-78  
NiCd, sintered plate, test/evaluation/charging of AA cells, 38-38  
NiCd, small rechargeable batteries, 37-97  
nickel-iron, negative experience (letters), 46-104  
nickel-iron, positive experience, 46-16  
nickel-metal hydride, (NiH), Ovonics (TtW!), 15-33  
portable, Consci Portable Power Pack (TtW!), 42-74  
rechargeable, small, 37-97  
recycling, lead-acid battery recycling, 49-72  
rejuvenation, L-A battery resoration using EDTA, 52-78  
safety, overcurrent protection devices, 27-26  
safety, short circuit protection, 17-37  
safety, tech notes, 27-69  
wiring, basics/L-A & NiCd w/wiring diagrams, 27-30  
wiring, cables, build for battery/inverter, 7-36  
wiring, interconnects, tech notes, 33-46

## Battery Chargers

120 vac to 12 VDC, Statpower 20 Amp charger (TtW!), 48-32  
Homebrew, AA Ni-Cd cells, 48-46

## Boating

Electric vehicles, PV-powered sailboat, 57-28  
Photovoltaics, Boat Lift, 57-50  
PV/Wind System, on sailboat, Cotterell, 53-12  
sailboats, book reviews, In Pursuit of Adventure and Freedom (sailing), 23-76  
sailboats, homemade 2 Amp wind generator, 5-9  
sailboats, Oldfield, PV and wind, 18-16

**Boating continued**

sailboats, tow-behind hydro generator (letters), 46-103

**Book reviews**

architecture, Resource Efficient Housing (directory), 26-77  
 architecture, Shelter (home design), 18-49  
 Box Beam Sourcebook, 43-86  
 business, The Incredible Secret Money Machine (home business), 17-51  
 business, The Incredible Secret Money Machine II (home business), 46-76  
 Capturing Heat, five cooker designs , 55-99  
 Code Check, A Field Guide to Building a Safe House, 56-92  
 conservation, The Fuel Savers, 25-77  
 Electric Burro On The Road To Bogota (travel), 18-49  
 electric vehicles, Alternative Transportation News (magazine), 22-81  
 electric vehicles, Build Your Own Electric Vehicle (Bob Brant), 41-54  
 electric vehicles, Convert It (Mike Brown & Shari Prange), 40-64  
 generators, The Homebuilt Dynamo, 32-86  
 greenhouses, The Hydroponic Hot House, 28-76  
 hot water heaters, anatomy, maintenance, trouble-shooting, etc., 51-73  
 In Pursuit of Adventure and Freedom (sailing), 23-76  
 Mavericks in Paradise (history), 23-76  
 Mutant Message Downunder (philosophy), 41-92  
 photovoltaics, Solar Electricity Engineering (college textbook), 46-75  
 power politics, A Solar Manifesto (environment and energy), 46-75  
 power politics, Sowing the Wind- Reflections on the Earth's Atmosphere, 23-77  
 PV, passive solar heat, The Evolution of an Independent Home, 51-72  
 PV, Types, construction, how they work, 50-76  
 reference, Alternative Energy Sourcebook 1990, 17-51  
 reference, Alternative Energy Sourcebook 1991, 22-81  
 reference, Ecologue (catalog), 21-86  
 reference, Shopping for a Better World (directory), 15-29  
 reference, Solar Electricity Today (directory), 23-76  
 reference, The Pocket REF, 31-93  
 reference, World Wildlife Fund Atlas of The Environment, 21-85  
 Sierra Club Green Guide, , 55-98  
 solar cooking, Heaven's Flame Solar Cookers, 19-52  
 solar cooking, Solar Cooking Naturally (cookbook), 37-109  
 system design, Buying Country Land, 29-78  
 System Design, collection of RE product spec sheets, over 200 pgs, 50-76  
 system design, The Solar Electric Independent Home Book, 18-49  
 system design, The Solar Electric Independent Home Book, 23-77  
 system, guide for choosing, installing & using RE, 51-73  
 The Bladeless Tesla Turbine, 19-52  
 The Complete Joy of Homebrewing (beer), 24-75  
 washing machines, Efficient Washing Machines, 23-77  
 Who Own the Sun?, IPP, 58-76  
 Wildfire Across America (firefighting), 23-77  
 wind, Wind Power for Home & Business (Paul Gipe), 36-88  
 wiring, Wiring 12 Volts For Ample Power, 20-61

**Business**

book reviews, The Incredible Secret Money Machine (home business), 17-51  
 book reviews, The Incredible Secret Money Machine II (home business), 46-76  
 career in RE, how to start, 26-36  
 home, basics, 34-87  
 home, plan, 35-89  
 profile of Solar Pathfinder, 26-40  
 systems, Home Power; PV 400 Wp, 12 L-A, 16-7  
 utilities, selling power to, 42-62

**Code Corner**

Codes & Standards, affect on cost & performance, 55-82  
 conductors, 31-74  
 disconnects for ac and DC systems, PV/wind/generator, 42-78  
 disconnects, 19-42  
 disconnects, 21-53  
 Example Systems, NEC PV stand-alone with generator back-up, 48-74  
 Ground Fault Protection, PV systems Checklist, 58-82  
 grounding, basics, 18-26  
 grounding, how to, 28-46  
 grounding, inverter grounding, 30-64  
 grounding, inverter grounding, 34-85  
 grounding, isolation, 25-65  
 grounding, surge and lightning protection, 32-68  
 grounding, why ground, 27-47  
 inspectors, 33-76  
 law, relation to National Electrical Code, 23-74  
 Lightning, safety & protection, 57-82

**Code Corner continued**

National Electrical Code, 1996 NEC and Cable update, 49-86  
 NEC and system protection, preventing accidents from beoming disasters, 52-86  
 NEC and UL requirements, photovoltaics, cables, overcurrent devices, 43-88  
 NEC and UL requirements, response to HP #43, voodoo electronics (letters), 44-84  
 NEC and UL requirements, response to HP#43, voodoo electronics, further (letters), 45-84  
 NEC PV module wiring methods & cables, 51-86  
 photovoltaics, example systems: stand-alone and grid-tied, 47-84  
 photovoltaics, grounding/overcurrent protection/fuses, 16-31  
 photovoltaics, history/relevance of National Electrical Code, 20-54  
 photovoltaics, purchase of, procurement manual, specs, 44-66  
 pumps, PV-powered, 26-57  
 pumps, PV-powered, example systems, 45-66  
 PV/NEC, Designing systems to meet code, 50-86  
 SAFETY ALERT, wiring, ac multiwire branch circuits, 54-82  
 SWRES Research, 13-42  
 systems, examples and remedies, PV, good/bad/ugly, 44-66  
 systems, examples, PV, small stand-alone, 46-84  
 systems, purchase of, procurement manual, specs, 44-66  
 UL listings, appliances, system components, etc., 56-82  
 water, pumping systems with PV, 45-66  
 wiring, load circuits, 22-68

**Cogeneration**

"shorties", also wind, photovoltaics, solar hot water, rainwater, 20-50

**Communications**

See also "Radio", & "Telephone"  
 Adopt-A-Library, matching funds for subscription, 47-101  
 computer, Home Power BBS/how to use, 39-40  
 computers, comm.power, 50-42  
 computers, Internet access, Home Power BBS, you too can have this, 43-91  
 computers, Internet, USENET newsgroup, Home Power BBS, 42-14  
 electric vehicles, Internet discussion address (letters), 47-63  
 glossary of renewable energy and battery terms, 47-78  
 HP's radio telephone system, , 56-50  
 Hughes/RCA Digital Satellite System (TtW!), 49-76  
 Photovoltaics, FM radio station, 54-6  
 PV/mobile ham shack, Bosbach, 86 Wp, 12V L-A, 50-38  
 Radio basics, remote communication options, 56-42  
 RE web site list, Comm Power, 55-40  
 Saving energy , with electronic communications, 58-71  
 shortwave radio, PV charging, batteries, antenna (Q&A), 47-108  
 Things that Work!, criteria and policies (letters), 46-102  
 travel, house swapping RE homes, 37-107  
 travel, RE user network (letters), 47-100  
 Writing for Home Power Magazine, share your renewable energy experiences!, 47-106

**Composting toilets**

see "Sanitation"

**Computers**

ac powered, efficient, 21-45  
 batteries, charging from PV (Q&A), 45-90  
 battery chargers, Homebrew, constant current charger, 44-54  
 Communications, comm.power, 50-38  
 communications, Home Power BBS/how to use, 39-40  
 communications, Internet access, Home Power BBS, you too can have this, 43-91  
 communications, Internet, USENET newsgroup, Home Power BBS, 42-14  
 communications, renewable energy bulletin boards, 27-60  
 Consci Portable Power Pack (TtW!), 42-74  
 Homebrew, 12 Volt regulator for Commodore 64, 23-71  
 inverters, how computers/printers run on mod sinewaves, 40-32  
 low power, 20-44  
 low voltage, 19-37  
 low-power computing, letters (see city off-grid), 42-105  
 PC Solar IBM daylighting simulator software (TtW!), 29-68  
 photovoltaics, portable charging, 38-32  
 printers, Apple Laserwriter II NT, 15-41  
 printers, Hewlett-Packard DeskWriter, 14-35  
 printers, Seikosha SP-1000AP, 16-52  
 RE web site list, Comm Power, 55-40

**Conservation**

appliances, finding phantom loads, 14-13  
 birds, effects of pollution (letters), 47-104  
 birds, wind vs. conventional, power politics, Audubon report, 47-10

## Conservation continued

birds, wind, power politics, 46-30  
 book reviews, The Fuel Savers, 25-77  
 electric vehicles, power use, pollution reduction, 45-42  
 Home load analysis, 58-38  
 in the city, 22-11  
 Phantom loads, Homebrew, detecting & eliminating , 55-36  
 rainforest, Amazon, Yacumama Lodge, eco-tourism w/PVs, 43-6  
 refrigerators, most efficient, Sun Frost RF-19 refrigerator/freezer (TtW!), 45-34  
 Saving energy , with electronic communications, 58-71  
 Sierra Club Green Guide, Book Review, 55-98  
 trees, paper cost/prices/recycling, 46-70  
 water heating, tank maintenance, anode replacement, source for, 45-30

## Controls

alternators, Homebrew, 12 VDC engine/generator w/ field controller, 2-23  
 DC-DC converters, Vanner Voltmaster (TtW!), 33-84  
 disconnects, required for ac and DC systems, PV, wind, generator, 42-78  
 Fan speed, 12VDC , ZANE (TtW!), 54-68  
 Home Brew, Charge controller, slave, 54-40  
 Homebrew, electric fence chargers, programmable pulse generators, 21-78  
 Homebrew, Renavair control panel, w/ 24 Volt Mark VI field controller, 22-73  
 Homebrew, timer for loads, ac to DC conversion, 16-49  
 Homebrew, timer for modified sine wave inverters, 51-76  
 hydro, systems, 13-35  
 linear current boosters, see "Linear current boosters"  
 maximum power point tracking, basics, description of, 29-34  
 PV, Heliotrope CC120E 120 Amp (TtW!), 48-36  
 regulators, see "Regulators"  
 switches, Homebrew, high voltage detector, 33-80  
 switches, Homebrew, voltage controlled, 16-50

## Cooling

see "Air conditioning" and "Refrigeration"

## Dr. Klüge

basics, electricity terms and laws, 31-78  
 basics, how transformers and LCBs work, 37-40  
 basics, resistors and diodes, 32-62  
 electricity, rms voltage, 32-50  
 electricity, timers and FETs, description of, 34-70  
 electricity, transistors, intro to, 33-32  
 induction and magnetism, Getting the Buzz Out, 35-77

## Editorial

alternatives, RE a solution to utilities dilemma, 20-46  
 conference, REDI Conference 1993, 37-78  
 conservation, energy conservation, 9-34  
 consumer's guide, an RE parable, 31-81  
 Costs of RE, how people can affect, 57-39  
 Electric vehicles, Carnegie Mellon Report, 49-73  
 electric vehicles, Electrathon, ZEVs, 51-50  
 electric vehicles, future of , 38-49  
 electric vehicles, introduction of GoPower, 37-50  
 energy farming, 46-4  
 etiquette, Good Manners, 31-36  
 freedom offered by RE, 22-35  
 future, musings on utilities, hydrogen, 29-28  
 Go Power, Solar racing, how many EVs, lead herrings, 49-50  
 GoPower, a teen's first car, 52-50  
 greenhouse effect and PVs, 10-14  
 IPP introduces themselves, 38-94  
 IPP, association & SCE update, 39-90  
 IPP, CPUC & SCE update, 41-94  
 IPP, Net metering, REDI'95, financing, SCEs off-grid, etc, 49-82  
 IPP, PV Commercialization, 48-71  
 IPP, update, 40-107  
 IPP/PV, National PV Production Statistics, 51-82  
 IPP/Utilities, California PV for Utilities (PV4U), 50-82  
 IPP/Utilities, Ontrio Hdyro, CA net metering, PV growth, 52-82  
 Lightning on Agate Flat, Muddy Roads, 55-68  
 Lunatic Fringe, 25-6  
 magazine mechanics, changing printers, paper, 35-18  
 magazine mechanics, recycled paper, author data, computer nerd stuff, 38-82  
 overview of Home Powers first fifty issues, 50-18  
 ownership of power, the utilities' involvement in solar energy, 37-4  
 photon's trip to earth, 25-68

## Editorial continued

photovoltaics, perks of using, 2-6  
 photovoltaics, state of the industry, 18-15  
 Power Politics, Corporate ethics, 57-86  
 RE, a matter of intent, 44-4  
 revolution, turnips, Smile, you are entering a grid-free zone, 42-4  
 solar, perspective, 4-35  
 spoof, Doktor Data explains sunshine, 34-58  
 storms, RE comes through unscathed, 45-4  
 the Wizard speaks, A Dream: 2027 AD, 44-78  
 utilities, selling power to, net billing, IPP non-profit organization, 42-62  
 utilities, utilities and the off-grid PV market, 37-91  
 Wisconsin, Renewables at work, Power Politics, 54-86

## Education

Adopt-A-Library, matching funds for subscription, 47-101  
 Back to Basics, renewable energy education sources, 30-72  
 careers in PVs, CMC, 3-20  
 Electric Vehicles, Junior Solar Sprint races, 53-64  
 EVs, building a high school electrathon racer, 40-58  
 glossary of renewable energy and battery terms, 47-78  
 Int'l Development Program at HSU, 41-78  
 Kid's Corner intro, 26-50  
 Kid's Corner: solar , 31-86  
 Kid's Corner: solar cooker designs, 27-74  
 Kid's Corner: solar experiments, 28-70  
 Kid's Corner: solar oven designs, 30-74  
 Kid's Corner: solar, wind, solid waste, 29-74  
 Midwest Renewable Energy Fair, highlights, 54-26  
 news on efficient PVs, wind, vacuum, SERI, 13-31  
 paper, cost/prices/recycling, 46-70  
 planetary citizens, amateur radio, 5-5  
 PV design & installation, SEI workshop, 10-20  
 PV for practitioners workshop, SEI (formerly ATA), 13-12  
 PV system, urban, Wausau WI, 600 Wp, 24 V L-A, 48-16  
 PV, batteries, loads (teaching plan, part 2) , 15-5  
 PV, Boy Scouts, Amateur radio, 32-71  
 RETSIE, 6-18  
 solar battery charging (teaching plan, part 1), 16-14  
 Solar cooking, for kids, Home & Heart, 57-90  
 solar cooking, Spanish-language pamphlet to build cooker, 44-50  
 sources, RE material, 30-72  
 Sustainable Energies Research Institute, 11-21  
 Systems, Photovoltaics, Hydro, Wind, BLM historical site, Bethea, 55-6  
 Videos reviews: PV, Wind, Hydro, Alternative Energy with the Experts, 56-93  
 Wind, Home built / restoration, 56-32  
 workshops, SEI, interties, batteries, inverters, Code, Safety, etc., 47-82  
 workshops, wind, PV, batteries/inverters, solar hot water, etc., 47-74

## Efficiency

Code Corner, Standards, affects on cost & performance, 55-82  
 education, workshops, MREA, 47-74  
 Home load analysis, , 58-38  
 lighting, most efficient available, LED Illuminators (TtW!), 44-33  
 lighting, retrofit of school w/fluorescents, 32-38  
 phantom loads, appliances that are always on, 37-46  
 Phantom loads, Homebrew, detecting & eliminating , 55-36  
 straw bale, comparisons, overview, sources, examples, 46-44  
 system design, whole-house, insulation, mass, etc, sources, Gimme Shelter, 46-37  
 utilities, efficiency of conventional power plants, Ask NREL, 45-62

## Electric vehicles

a potluck of EVs & letters, 51-53  
 aerodynamics, terms, overview, 47-66  
 aircraft, solar powered ultralight, 19-6  
 aircraft, solar vs. other, energy comparison, 19-8  
 basics, wiring (part 1), size, cable, strap, identify, protect, etc., 42-52  
 basics, wiring (part 2), measure, connect, ground, fuse, relay, etc., 43-52  
 batteries, conversion, overview, 35-50  
 batteries, EV fueling techniques, 36-57  
 batteries, Wh/lb and price comparison (letters), 47-62  
 battery chargers, Homebrew, 0-140VDC, autotransformer, 110 rectified, 47-59  
 battery chargers, types, issues, sources, 46-64  
 battery, lead acid recycling, 48-61  
 bicycle power assist, ZAP Power System, 43-46  
 bicycles, also solar- and human-powered (photo), 46-56  
 boats, 1st Spada Lada Electric Boat Race, 32-18  
 boats, 2nd Annual Spada Lake electric & solar races, 39-48  
 boats, Marine Electric Propulsion, 37-70  
 boats, solar powered, 26-30

**Electric vehicles continued**

book reviews, Build Your Own Electric Vehicle, by Bob Brant, 41-54  
 book reviews, Convert It, by Mike Brown w/Shari Prange, 40-64  
 book reviews, design, Box Beam Sourcebook, 43-86  
 Bradley GT, Gail Lucas, 42-46  
 brakes, electric-assist brake, 44-36  
 Charging and Maintenance, 48-60  
 Citicar, Gail Lucas, 42-46  
 commuter, 96V, DC series motor, 16 6V L-A, 60-80 mi, 55 mph, 45-42  
 computers, Internet discussion address (letters), 47-63  
 controllers, conversion, speed control, 37-74  
 conversion, adaptors, 34-40  
 conversion, battery chargers, explanation & shopping for, 40-66  
 conversion, battery containment & placement, 36-52  
 conversion, choosing a car for, 31-32  
 conversion, experience by first-timer, 45-42  
 conversion, Kawasaki 2WD to electric mule, 41-46  
 conversion, power accessories/options, 41-56  
 conversion, troubleshooting of circuits, batteries, etc., 45-50  
 conversion, what to save, what to scrap, 32-48  
 conversion, wiring (part 1), size, cable, strap, identify, protect, etc., 42-52  
 conversion, wiring (part 2), measure, connect, ground, fuse, relay, etc., 43-52  
 conversions, pickup truck (photo), 45-46  
 conversions, suspension: data, springs, shocks, struts, alignment, etc., 44-46  
 conversions, trucks, 9" DC series motor, 120V, regen, 84 Dodge D50, 47-54  
 conversions, Voltsrabbit, 96V, DC series, 16 6V L-A, 60-80 mi, 55 mph, 45-42  
 crashworthiness, crash tests, 40-50  
 design, experiences designing & racing EVs, 40-54  
 editorial, Carnegie Mellon Report, 49-73  
 editorial, Electrathon, ZEVs, 51-50  
 editorial, solar racing, how many EVs, lead herrings, 49-50  
 editorial, towards an EV future, 29-31  
 editorial, Tropica, CARB, 42-44  
 editorial, ZEV mandate, electric-assist brake, instrumentation, 44-36  
 education, building a high school Electrathon racer, 40-58  
 education, building an Electrathon vehicle at a junior high school, 44-38  
 education, Jordan Energy Institute, 21-32  
 Education, Junior Solar Sprint races, 53-64  
 efficiency, auto emission pollution, 18-9  
 efficiency, energy consumption in ZEVs and HEVs, 37-57  
 efficiency, performance testing 1992 American Tour de Sol, 34-62  
 efficiency, reasons for owning, 18-11  
 electrathon racing, SEER '94 Electrathon, 43-56  
 electrathon, building a high school Electrathon racer, 40-58  
 electrathon, Lightning Series by Dann Parks, 43-48  
 electrathon, Panther Electric junior high project, 44-38  
 electrathon, SEER '94 racing and results, 43-56  
 electric wheelbarrow, 43-40  
 energy, gasoline-to-electric equivalents, 42-48  
 EV driving techniques, 49-68  
 fuel cells, intro to hydrogen fuel cells, 23-16  
 Gardening, walking tractor conversion, 53-53  
 grid power emissions, 56-70  
 Homebrew, build a solar-powered vehicle, 14-27  
 Homebrew, building a shopping cart racer, 50-64  
 Homebrew, building an Electrathon vehicle, Box Beam, 44-38  
 Homebrew, controllers/relays, simple, 39-53  
 Homebrew, design & construction of a shopping cart racer, 49-62  
 Homebrew, dynamic braking (part 1 of 3, all needed), 42-56  
 Homebrew, dynamic braking (part 2 of 3) (Letters, see Problem Relay), 43-99  
 Homebrew, dynamic braking (part 3 of 3) (EV Q&A), 45-54  
 Homebrew, frames, 15-42  
 Homebrew, regenerative braking, 38-52  
 Homebrew, Shopping Cart Racing, 48-52  
 Homebrew, solar powered dune buggy, 34-20  
 Homebrew, suspension: data, springs, shocks, struts, alignment, etc., 44-46  
 Homebrew, VW Rabbit conversion, part 1, 51-62  
 Homebrew, VW Rabbit conversion, part 2, 52-52  
 Homebrew, VW Rabbit conversion, part 3, 53-60  
 Honda R&D EVs, delivered to Pacific Gas & Electric, 45-39  
 hybrids, general, 8-5  
 hybrids, overview, 9-13  
 hybrids, solar electric/ natural gas prototype, 31-108  
 instrumentation, conversion, gauges for the working EV, 39-58

**Electric vehicles continued**

instrumentation, tachometer sensors, meter drivers, 44-36  
 international, British Battery Vehicle Society (letters), 47-63  
 international, British EV society, Dorset (letters), 46-104  
 International, electric rickshaws in Kathmandu, 49-52  
 international, EVs in Europe & renting an EV in Geneva, 38-64  
 international, Isle of Man, education, racing, publicity, 45-54  
 Lightning Series, Dann Parks, Electrathon, 43-48  
 maintenance, troubleshooting of circuits, batteries, etc., 45-50  
 motors, conversion, types and tips, 33-38  
 overview, myths debunked, 46-59  
 overview, various conversions, purpose-built, production & kit models, 44-42  
 parts, access data, 19-54  
 pen pals wanted—Kansas City, letters, 42-105  
 politics, CARB ZEV mandate, 44-36  
 Prototyping, aluminum box beam, 54-50  
 PV inertia, Heckerth, 3 Kw, 24V L-A, 50-57  
 PV powered sailboat, 57-28  
 race, Universities compete in solar car race, 50-50  
 racing, at Phoenix, part 1, 54-53  
 racing, '91 Phoenix Solar & Electric 500, 23-66  
 racing, '92 Phoenix Solar & Electric 500, 30-16  
 racing, 1990 American Tour de Sol, 18-7  
 racing, 1991 American Tour de Sol, 24-35  
 racing, design/development of open class racer, 39-44  
 racing, Electrathon, high school, 41-50  
 racing, new speed records & old EV frames, 41-44  
 racing, car & race types, 55-62  
 racing, driving techniques, 57-56  
 racing, safety & protocol, 56-64  
 racing, drag & speed records, 58-56  
 racing, rapid recharging, 33-109  
 racing, safety, 30-22  
 racing, Snowwhite EV vs. gas stock car, 43-40  
 racing, statistics, photos, 46-59  
 road test, an electric bicycle, 48-57  
 safety, conversion, disconnects, circuit breakers, fuses, 38-60  
 safety, design, operation & maintenance, 51-58  
 safety, safety features for the EV conversion, 50-68  
 scratchbuilt, gear ratios (EV Q&A), 45-55  
 scratchbuilds, Sunray, 3-wheel, 12HP DC series, 120V, 45-46  
 scratchbuilds, tractor (photos), 45-46  
 solar, '90 World Solar Challenge, Australia, 21-29  
 solar, 4 PV panels, 12V L-A, Tom Bennett/Eileen Niedermann, 42-48  
 solar, building a solar vehicle, 14-30  
 solar, PV panel construction for racer, 37-52  
 Speedster Two, 72V, 4.5HP, 600lbs, 43-42  
 SunCoaster, 4 PV panels, 12V L-A, Tom Bennett, 42-48  
 suspension, data, adjustment, springs, shocks, struts, alignment, etc., 44-46  
 Tech Talk, Diagnosing battery condition, 57-105  
 Tech Talk, range, car type, battery treatments, 58-62  
 The Hawk electric motorcycle, 49-58  
 three-wheel, design considerations (letters), 46-101  
 tires, overview, issues, 46-66  
 tractors, BoxBeam, PM motor, 12V/1HP or 24V/2HP, 47-52  
 Trike, w/ pedal & Zap, The Phantom, 55-56  
 trucks, conversions, 9" DC series, 120V, regen, 84 Dodge D50, 47-54  
 video reviews, EVs & Hydrogen, 27-78  
 video reviews, Hand Made Vehicles, 43-40  
 wiring, (part 1), sizing, cable, straps, identifying, protecting, looms, 42-52  
 wiring, (part 2), measuring, connectors, extra wires, grounds, fuses, relays, 43-52  
 ZAP Power System for bicycles, 43-46

**Electricity**  
 Basics, alternating current, part 1, sinewaves, 52-74  
 Basics, alternating current, part 2, phase & power, 53-44  
 basics, Dr Klüge, induction and magnetism, 35-77  
 basics, Dr Klüge, rms voltage, 32-50  
 basics, Dr Klüge, terms and laws, 31-78  
 basics, Dr Klüge, timers and FETs, 34-70  
 basics, Dr Klüge, transistors, 33-32  
 basics, Electricity for Dummies, Part 1, by "Dr. Demento", 44-62  
 basics, resistors and diodes, 32-62  
 basics, schematics, how to read, 5-35  
 basics, terms, definitions, 29-72  
 basics, terms: amps, volts, watts, watt-hours, amp-hours, 1-35  
 basics, transformers and LCBs, electronics, 37-40  
 Basics, understanding DC electricity, 52-64

## Electricity continued

Basics, understanding series & parallel circuits, 53-38  
 basics, wiring, low voltage techniques, sizing, 2-33  
 batteries, lead-acid, how they work, how to care for, 47-30  
 cartoon describing amps and volts, 25-67  
 definition of terms, 29-72  
 history, ac vs. DC, 8-21  
 Home load analysis, , 58-38  
 motors, how electric motors work, 34-48  
 Ohm's law , definition, 3-40  
 Ohm's law, applications, 4-33  
 Ohm's law, digital multimeters, 16-46  
 reliability, RE vs utility (letters), 46-100  
 shunts, multimeters, to measure current, Cu shunt table, 6-35  
 soldering, basic how to, 18-35  
 soldering, Pensol portable gas soldering iron (TtW!), 16-39  
 wiring, sizing tables, DC/PV, 18-31

## Electromagnetic fields

ac, reducing EMF, 24-62  
 Homebrew, ac field meter, 23-26  
 Homebrew, simple magnetic field meter, 34-79  
 Induction and magnetism, Getting the Buzz Out, 35-77  
 Metering, TriField (TtW!), 54-73  
 systems (PV etc), health effects, 23-24

## Emergency equipment

appliances, 16-30  
 Camp Fires's B-B-Q Box (TtW!), 28-65  
 Consci Portable Power Pack (TtW!), 42-74  
 emergency micropower systems, 14-9  
 emergency power system, 25-33  
 micro system: Sovonics PV, Ovonics battery (TtW!), 15-33

## Energy

cold fusion, non-ecological, 43-97  
 conversion, gasoline-to-electric equivalents, 42-48  
 conversion, kiloWatt-hours to Sherpa-weeks, 45-70  
 Costs of RE, how people can affect, 57-39  
 editorial, freedom offered by RE, 22-35  
 efficiency, appliances that are always on, phantom loads, 37-46  
 electricity, basics, Electricity for Dummies, Part 1, by "Dr. Demento", 44-62  
 embodied, various building materials, chart, straw bale info, 46-44  
 etiquette, Good Manners, 31-36  
 free, impact of, the Wizard speaks, 45-82  
 future, musings on utilities, hydrogen, 29-28  
 home power movement, 45-64  
 human energy converter (HEC), bicycle parts + people = power, 1036 Wp, 24 V, 43-78  
 nuclear, costs, "give it up", 45-73  
 organizations, profile of Redwood Alliance, 12-22  
 photovoltaics, amount to produce cells vs. that produced by cells, 43-73  
 physics, charge/energy and mass/energy, 8-33  
 selling RE to utilities, 42-62  
 stud muffins & kW-hrs, they ought to call them Sherpa-weeks, 45-70  
 survey, voters choose between RE, coal & oil, etc., 45-64  
 terms, conversion of units, 19-46  
 utilities, hidden costs, 16-21  
 zero-point field, challenges quantum & relativity, 46-98  
 zero-point field, ZPF virtual photons, New Energy News, 42-100

## Energy Fair

Energy Fair Update, Initial Responses, 13-24  
 inspiration for installing RE, 46-6  
 MREF '90, Midwest Renewable Energy Fair, Amherst, WI, 19-16  
 MREF '91, Midwest Renewable Energy Fair, Amherst, WI, The Spark, 24-32  
 MREF '92, Midwest Renewable Energy Fair, Amherst, WI, 30-10  
 MREF '93, Midwest Renewable Energy Fair, Amherst, WI, 36-6  
 MREF '94, Midwest Renewable Energy Fair, Amherst, WI, 42-22  
 MREF '95, Midwest Renewable Energy Fair, Amherst, WI, 49-22  
 MREF '96, Midwest Renewable Energy Fair, Amherst, WI, 54-26  
 People's Energy Fair, "A Dream", 12-27  
 Reports, 1990, 19-12  
 SEER '91, Solar Energy Expo & Rally, Willits, CA, 25-26  
 SEER '92, Solar Energy Expo & Rally, Willits, CA, 31-12  
 SEER '94, Solar Energy Expo & Rally, Willits, CA, 43-19  
 The Farm, Summertown, TN '90, AE fair held at The Farm, 18-40

## Engines

battery charger, Heliotrope HC-75 (TtW!), 17-38  
 engine/generators, small gas engines compared, 42-29  
 fuel, transportation, handling and storage, 4-18

## Engines continued

Homebrew, electronic ignition, 7-30

## Fuel cells

EV, intro to, 23-16  
 Homebrew, hydrogen, 35-42  
 hydrogen, overview of 5 types, 35-37

## Gardening

Cider press, Home & Heart, 56-90  
 Electric Vehicles, walking tractor conversion, 53-53  
 greywater, CCAT, also PV: 450 Wp, 12 V L-A; wind: 500 W, 32-6  
 Home & Heart, Figs, grapevines & garlic, 49-92  
 Log splitter, Homebrew, electric conversion, 55-32  
 photovoltaics, minisystem for charging mower, etc. (Q&A), 43-108  
 rainwater, "shorties", also wind, photovoltaics, solar hot water, cogen, 20-50

## Generators

back-up power, choosing and employing effectively, 51-66  
 batteries, charging with (Q&A), 43-107  
 Bicycle-powered, track stand conversion, 56-75  
 book reviews, The Homebuilt Dynamo, 32-86  
 charging batteries with gas generator, 3-32  
 electricity, basics, 42-35  
 engines, choosing, using, 1-19  
 Homebrew, 12 VDC engine/generator, 2-23  
 Homebrew, 12 VDC w/field controller, updated, 42-28  
 PV/systems, YAGO, 2.4 Kw, 24 V, 7 Kw generator, 50-32  
 systems, "shorties", also wind, photovoltaics, temporary, 17-46  
 systems, Haeme (shop, trailer); 4000 W; PV 360 Wp, 12 V L-A; grid, 47-24  
 systems, Kingman (CA); PV 848 Wp, 24 V N-I; gen 7.5 kW propane, 46-16  
 systems, Lasley (OR); PV 146 Wp, 12 V L-A; gen, 44-16  
 systems, Pryor; PV 200 Wp, 12 V L-A; generator, 2-7  
 systems, Reichenbach; also PV, 42-18  
 systems, Yacumama, Amazon; gen: 6.5 kW; PV: 576 Wp, 24 V L-A, 43-6

## Glossary

basics, electricity terms and laws, 31-78  
 definition of Home Power terms, 18-52  
 renewable energy definitions, 39-108

## Greenhouse

PV powered ventilation, 34-55  
 book reviews, The Hydroponic Hothouse, 28-76  
 Passive Solar, Sun room add-on, Sexton, 53-16

## Greywater

see "Gardening" and "Sanitation"

## Health & Environment

Electromagnetic Fields, measuring, TriField (TtW!), 54-73  
 lighting, effects of, 30-32  
 microwaves, what are/where from/hazardous?, 35-67  
 paper, use, cost, recycled, 46-70

## Heat

definitions, 2-27

## Heating pads

12 Volt Products' heating pad (TtW!), 29-58  
 Electro-Bed-Warmth 12 VDC bed warmer (TtW!), 8-36

## Home & Heart

appliances, Asko dish washer, 52-94  
 appliances, buying a dishwasher, 50-92  
 bicycle grinders, 32-81  
 book reviews, A Bite of Independence, week's meals for \$10 & 2-1/2 hours, 42-96  
 book reviews, Morning Hill Cookbook, solar, philosophy, 47-92  
 book reviews, The Encyclopedia of Country Living, by Carla Emery, 42-96  
 Bread Machine, , 58-90  
 build a solar barrel composter, 35-96  
 Cider press, , 56-90  
 earthquake, 29-76  
 food clubs, vacuums, 24-73  
 Gardening, Figs, grapevines, garlic & a ranch house retrofit, 49-92  
 garlic, fluorescent lights, Thermomax water heater, 28-72  
 hand appliances, low flow toilets, food coops, 31-87  
 Hawaii RE food processing & eco-tourism, 33-92  
 herbal medicine video, 39-92  
 Home improvement pay-off, clothes dryer, 51-92  
 Homebrew, simple stove top toaster, 48-82  
 Mud rooms, , 55-92

**Home & Heart continued**

open-pollinated seed, box gardens, 25-75  
 Peerless-Priemer efficient gas cook stove, 40-108  
 RE homemakers, 22-71  
 solar cooking, recipes, 41-95  
 solar cooking, Solar Chef—solar cooker extraordinaire, 44-74  
 Solar Cooking, teaching kids, 57-90  
 solar food drying, 30-75  
 solar turntable, 34-96  
 Sun Frost refrigeration, seeds, 26-75  
 Sun Frost refrigerator, gophers & garlic, 27-76  
 travel, house swapping RE homes, 37-107  
 utilities, conspicuous consumption in PG&E's "houses of future", 43-93  
 vacuums, Maytag washers, 23-79  
 video reviews, Co-dependent Ecology, save-energy tour w/13-yr old boy, 42-96  
 video reviews, Creating a Healthy Home, chemicals to toxic-free, 42-96  
 washing machines, brands compared, 46-92  
 washing machines, reader letters of experiences, 45-76  
 washing machines, Staber System 2000 H-axis front-loader (TtW!), 47-70  
 women, MREF '93, 36-86

**Homebrew**

batteries, 12 or 24 Volt portapower, 24-70  
 batteries, charging, constant current source, 21-82  
 batteries, charging, constant current, 23-69  
 batteries, low cost, high/low battery voltage alarm, 39-62  
 Battery Charger, AA Ni-Cd cells, 48-46  
 Battery Charger, for small NiCd, Linn, 53-34  
 battery chargers, constant current, efficient, 44-54  
 Charge controller, slave, , 54-40  
 controls, regulators, 3 terminal, adjustable (TtW!), 6-37  
 controls, Renavair control panel, w/24 Volt Mark VI field controller, 22-73  
 controls, switch, voltage controlled, multi-purpose, 16-50  
 controls, timer for loads, ac to DC conversion, 16-49  
 Controls, timer for modified sine wave inverters, 51-76  
 DC timer, variable, 54-44  
 DC-DC converters, run 12V appliances on 24V battery, 3 amps, cheap!, 39-68  
 electric fence chargers, programable pulse generator, 21-78  
 Electric vehicles, building a shopping cart racer, 50-64  
 electric vehicles, design & construction of a shopping cart racer, 49-62  
 electric vehicles, motor controllers/relays, simple, easy to build, 39-53  
 electric vehicles, odometer, 26-64  
 electric vehicles, regenerative braking, 38-52  
 electromagnetic fields, ac meter, 23-26  
 electromagnetic fields, meter, simple, 34-79  
 electronic parts catalogs/sources, 8-40  
 engine/generators, 12 VDC w/ field controller, 2-23  
 engine/generators, 12 VDC w/field controller, updated, 42-28  
 engines, electronic ignition for, 7-30  
 EV, VW Rabbit conversion, part 1, 51-62  
 EV, VW Rabbit conversion, part 2, 52-52  
 FET, care and feeding, 45-58  
 fuel cells, hydrogen, make electricity with, 35-42  
 health & environment, microwave oven leakage detector, 35-72  
 Home & Heart, simple stove top toaster, 48-82  
 hydrogen, barbeque grill, 43-24  
 instrumentation, ammeter & voltmeter, 35-92  
 instrumentation, ammeter, ac, beginner's, 33-82  
 instrumentation, ampere-hour meter, 26-42  
 instrumentation, ampere-hour meter, digital, 30-68  
 instrumentation, low-voltage detector, 120 vac, 32-57  
 instrumentation, wattmeter, 30-45  
 inverters, 156 Volt DC transformerless, 36-71  
 inverters, tricks for square wave inverters, 31-69  
 lighting, 12 VDC night light, 23-70  
 Lighting, 12 VDC night night, Raynes, 53-30  
 Lighting, 120 vac LED night night, Morris, 53-32  
 lighting, convert 120vac halogen lamp to 12VDC, 35-30  
 lighting, convert ac lamp to 12 VDC quartz halogen, 18-47  
 Log splitter, electric conversion, 55-32  
 motor controller, DC, 12V, 24V, variable or hi/low speed, 45-58  
 motors, soft-starting, 23-72  
 NiCd charger, pulsar PWM charging, 30-54  
 NiCd charger, pulsar PWM charging, 5-27  
 NiCd charger, simple, 23-71  
 NiCd charger, wall cube replacement, 26-72  
 Phantom loads, detecting & eliminating , 55-36

**Homebrew continued**

pumps, ram, simple/effective hydraulic, 41-74  
 PV powered lawn mower, Knapp, 28 Wp, 12V L-A, 50-72  
 refrigeration, Solar ammonia absorption ice maker, Vanek & Green, 53-20  
 refrigerator/freezer, DC, 21-8  
 refrigerator/freezer, DC, insulation, 16-48  
 regulators, "latchup" shunt voltage, 25-74  
 regulators, array-direct power point, run motor from PVs, 38-72  
 regulators, Commodore 64, 12 Volt, 23-71  
 regulators, DC power supply converter, 29-69  
 regulators, PV direct, 32-46  
 regulators, run a stereo on battery & solar power (sidebar), 40-105  
 regulators, short circuit 35 Amp, 28-57  
 regulators, shunt, 18-46  
 schematics, how to read basic, 5-35  
 solar cooker, contest winner 1994, 43-33  
 solar cooking, box cookers, 12-14  
 solar cooking, Heaven's Flame Solar Cooker, 20-27  
 solar cooking, HP '92 cooker contest results, 31-38  
 solar cooking, HP '93 cooker contest winner, 37-22  
 solar cooking, parabolic, "Berkeley Thernonuclear Paraboloid", 37-34  
 Solar food dryer, concepts & plans , 57-62  
 solar food drying, arid climates how-to, 29-64  
 solar food drying, humid climates how-to, 29-62  
 Solar Sight (sun's path for winter), 28-61  
 solar water distillation, water pasteurization for developing countries, 52-44  
 Solar water heating, thermosyphon, how to build, Homebrew, 58-30  
 SunSighter (point panels to sun), 26-73  
 System/Hydro, Gima & Puttre, dirt cheap hydro, 66Wp, 12V L-A, 52-14  
 systems, portable, PV, small (computer, radio), 38-32  
 towers, and wind generator, 1.5kW 24VDC, 42-38  
 trackers, active solar, 17-48  
 trackers, manual, 13-20  
 voltage converter, build a buck converter, 37-82  
 voltmeters, expanded scale, 12-34  
 voltmeters, expanded scale, 2-31  
 voltmeters, LED bargraph, 10-26  
 washing machines, converting a wringer washer to DC, 40-40  
 water heating, economy solar shower, 43-30  
 watt-hour meters, on 120 volt systems, 17-50  
 wind generators, 1.5kW 24VDC and tower, 42-38  
 Wind Tower, Tilt-up conversion of Rohn, 56-38  
 wind, build your own wind generator, 12-29  
 wind, Dailey, Cheap Towers, 52-24  
 wind, utility pole/pipe tower, 28-26  
 wiring, cables, build for battery/inverter, 7-36

**HP Survey**

energy satisfaction, survey blank, 42-16  
 Home Power Book Survey, 30-66  
 renewable energy, reader response to May '89 survey, 10-25  
 respondents' comments, (letters), 43-101  
 respondents' comments, (letters), 44-86  
 respondents' comments, (letters), 45-88  
 results, energy satisfaction, RE and/or grid, 43-16  
 results, energy satisfaction, RE and/or grid, Part 2, 46-78

**Hydro**

basics, great article, overview of all the basics, 44-24  
 basics, pressure, flow, head, velocity, turbines, efficiency, etc., 42-34  
 chart, poly pipe table, pressure loss vs. gpm, 8-25  
 chart, PVC pipe table, pressure loss vs. gpm, 8-26  
 controls, systems, 13-35  
 editorial, "Seeking Our Own Level", 2-17  
 Energy System & Design's Stream Engine (TtW!), 30-50  
 generators, induction, 3-17  
 Lil' Otto, nano hydro, 13-15  
 linear current boosters, PM generators, 17-39  
 low-head, Olson, Overshot low head hydro, 37-6  
 low-head, ultra-low, 23-6  
 profile of Uncle Len's story, 3-13  
 sailboats, tow-behind (letters), 46-103  
 sidebar, hydro turbine runners, 25-12  
 sidebar, the physics of falling water, 37-9  
 system design, how to, weir measurement table, 8-17  
 system design, nano-hydro, 15-17  
 system design, small, overview, 1-7  
 system design, solar, hydro, and wind, 21-75  
 system design, ten rules for surviving microhydroelectric power, 47-16  
 system, Spencer, living with Lil Otto in Australia, 52-40

## Hydro continued

System/Homebrew, Gima & Puttre, dirt cheap hydro, 66Wp, 12V L-A, 52-14  
 systems, Gaydos, Hydrocharger, 40 ft/8 gpm. 50 Wp PV, 11-5  
 systems, Higgs, Morgan-Smith turbine, 17 ft head/ 10,000 gpm , 25-7  
 systems, Kennedy Creek, 5 systems, high head, 100 to 2200 watts, 20-7  
 systems, Kinzel/Kingsley (MI); 16ft/75gpm, FAT, 12V L-A; PV 480 Wp, 47-16  
 systems, Nicaragua, 78 ft/160 gpm, 12 V lead-acid, 8-13  
 systems, Purcell Lodge, IPD pelton, 315 ft head/ 220 gpm, 12 kW, 33-12  
 systems, Rakfeldt, Harris turbine, 300 ft/400 gpm, 24 V, 6-5  
 systems, Schultze, ES&D hydro, PV/wind/hydro/DHW, 41-6  
 Systems, w/ PV, Wind, BLM historical site, Bethea, 55-6

## Hydrogen

as potential fuel, 21-17  
 communications, sources of info in UK and US (letters), 47-102  
 cooking with, converting stove top, 33-28  
 electric vehicles, intro to fuel cells, 23-16  
 electrolyzer, making electrolyte, storage of, 22-32  
 electrolyzers, description of, 26-34  
 electrolyzers, home-sized solar hydrogen project, 39-32  
 electrolyzers, intro to, calculations, 32-42  
 fuel cells, building a hydrogen fuel cell (homebrew), 35-42  
 fuel cells, overview of 5 types, 35-37  
 heating, heater conversion gas to hydrogen, 34-26  
 Homebrew, barbeque grill, 43-24  
 how to, safety of, 21-55  
 systems, Schatz experimental PV/hydrogen, 22-26  
 video reviews, EVs & Hydrogen, 27-78

## Instrumentation

ammeters, Homebrew, & voltmeter, 35-91  
 ammeters, Homebrew, ac, beginner's, 33-82  
 ammeters, Homebrew, and voltmeters, sidebar, 35-92  
 ampere-hour meters, Ample Power Company's Energy Monitor (TtW!), 20-40  
 ampere-hour meters, Cruising Equipment (TtW!), digital, 16-40  
 ampere-hour meters, Cruising Equipment's Amp-Hour +2 Meter (TtW!), 26-59  
 ampere-hour meters, Digital Amp-Hour Meter (TtW!), 16-40  
 ampere-hour meters, Homebrew, 26-42  
 ampere-hour meters, Homebrew, digital, 30-68  
 ampere-hour meters, Offgrid's Power Meter 15 (TtW!), 25-61  
 ampere-hour meters, Steamco Solar SPM2000 (TtW!), 27-56  
 ampere-hour meters, Thomson & Howe (TtW!), 11-39  
 angle indicators, for PV module, tech notes, 32-67  
 computerized, RMS Datalogger (TtW!), 34-76  
 Cruising Equipment's E-Meter (TtW!), 52-30  
 Cruising Equipment's Link 2000 (TtW!), 50-46  
 electric vehicles, gauges for the working EV, 39-58  
 electromagnetic field meters, Homebrew, super simple, 34-79  
 Electromagnetic Fields, measuring, TriField (TtW!), 54-73  
 grid meters, formula/using to figure watt-hrs, 34-30  
 low voltage detectors, Homebrew, 120 vac, 32-57  
 multimeters, and Ohm's law, 16-46  
 multimeters, and shunts to measure current, Cu shunt table, 6-35  
 multimeters, Beckman 2020, digital (TtW!), 32-54  
 multimeters, Cygnet M-32 Battery Monitor (TtW!), 26-62  
 multimeters, digital, Ohm's law, 16-46  
 multimeters, Fluke 87 DMM, 15-41  
 shunts, and multimeters to measure current, Cu shunt table, 6-35  
 system monitor, Offgrid's Power Meter 15 (TtW!), 25-61  
 system monitors, Homebrew, shunt table, multimeter, amp-hr meter, voltmeter, 24-42  
 voltmeters, Homebrew, expanded scale, 12-34  
 voltmeters, Homebrew, for battery, 2-31  
 voltmeters, Homebrew, LED bargraph for battery, 10-26  
 voltmeters, SunAmp's Bar Graph Voltmeter (TtW!), 22-55  
 watt meters, Homebrew, 30-45  
 watt meters, Offgrid's Power Meter 15 (TtW!), 25-61  
 watt meters, Steamco Solar SPM2000 (TtW!), 27-56  
 watt-hour meters, Homebrew, using on 120 volt systems, 17-50  
 wind, NRG Sou'wester & 2100 Totalizer (TtW!), 28-55  
 wind, odometer, Homebrew, 26-64  
 wind, Trade Wind's wind odometer (TtW!), 22-53  
 Africa, Uganda PV (letters), 47-100  
 Australia, hydro, Spencer, living w/ Lil Otto, 52-40  
 Chile, wind, photovoltaics, solar cooking, 28-20  
 Cuba, Renewable Energy happenings, 55-26  
 Dominican Republic, Photovoltaic water pumping, 56-16

## International continued

El Salvador, photovoltaics and solar ovens, 35-58  
 electric vehicles, electric rickshaws in Kathmandu, 49-52  
 Falkland Islands, Systems, Wind, Wilkinson, 55-18  
 Guyana, PV powered health care in, 20-37  
 Nepal, Systems update, Ramsey, 56-56  
 Nicaragua, hydro in, 78 ft/160 gpm, 12 V lead-acid, 8-13  
 Peru, Solar Cooking, 57-44  
 photovoltaics, Eastern Africa solar, 41-20  
 photovoltaics, funding by US Dept. of Energy, 46-82  
 photovoltaics, PV in rural Chinese village, 41-32  
 solar cooking, how solar cooking changed a Chilean village, 41-28  
 solar cooking, Peru, pamphlet to teach construction/use (Spanish), 44-50  
 South America, PV refrigerators in, 21-20  
 Spain, Systems, Photovoltaics, Zirkel, 56-26  
 systems, Amazon, Yacumama Lodge, PV: 576 Wp, 24 V L-A; generator, 43-6  
 systems, Colombia, PV system for health center, 32-99  
 systems, El Salvador, PVs in, 31-28  
 systems, Mexico, Chatuco, PV: 960 Wp 24 V L-A, 10-5  
 systems, Nepal monasteries (2), 100 Wp, 12 V L-A, 45-6  
 systems, New Zealand, PV/wind, Soma 300 W, PV/wind hybrid economics, 18-21  
 systems, PV for medical clinic in Vietnam, 38-46  
 systems, PV in Honduras, Central America, 34-14  
 systems, PV in Sri Lanka, 37-19  
 systems, PV, Wind & Hydro systems in New Zealand, 49-36  
 systems, SELFs Solar Electricity for Rural Women, 50-6  
 utilities, Swiss & German rate-based model to motivate PV market, 44-20  
 wind, China, number of installed generators, 43-61

## Inverters

appliances on, 14-11  
 basics, 1-22  
 basics, how they work, 23-53  
 basics, what is, history, 32-22  
 comparison of 12 makes, 36 models, 36-34  
 comparison, SEER '90, 19-29  
 computers, how computers/printers run on mod sinewaves, 40-32  
 Dynamote's 2.4 kW. sine wave (TtW!), 31-54  
 education, workshops, MREA, 47-74  
 electrical noise and inverter filters, 14-35  
 Heart's 2.5 Kw inverter (TtW!), 50-46  
 Heliotope PSTT 2.3 kW (TtW!), 3-29  
 Homebrew, 156 Volt DC transformerless inverter, 36-71  
 Homebrew, tricks for square wave inverters, 31-69  
 PowerStar POW200 (TtW!), 15-36  
 PowerStar's UPG1300 (TtW!), 22-22  
 safety, fuses for/wiring protection, 24-66  
 sine wave, Exeltech 1000 watt sine wave (TtW!), 39-74  
 sine wave, Exeltech SI-250 (TtW!), 27-53  
 sizing, small or med-small (Q&A), 43-108  
 Statpower's PROwatt 600 (TtW!), 20-48  
 telephones, 3 ways to keep buzz out, 38-78  
 Trace 1512 with charger (TtW!), 2-29  
 Trace 2012 (new) with charger (TtW!), 25-58  
 Trace 2012 with charger (TtW!), 8-29  
 Trace 2512 (TtW!), 35-74  
 Trace 2524 w/charger (TtW!), 16-42  
 Trace 4024 4.0 kW Sine Wave (TtW!), 48-26  
 Trace 812SB (TtW!), 28-53  
 Trace SW2512, (TtW!), 58-46  
 Trace upgrade, 22-57  
 wiring, to mains panel, 11-23

## Lighting

12 VDC, 12VDC quartz halogen/20W (TtW!), 40-92  
 12 VDC, choices, applications, sources (Q&A), 47-107  
 12 VDC, fluorescent and incandescent, 1-31  
 12 VDC, LED Christmas lights (TtW!), 8-37  
 12 VDC, LED flashlight lamps (TtW!), 34-68  
 12 VDC, Northern Lites' tail-light bulb adapters (TtW!), 4-28  
 12 VDC, Solar Retrofit's Fluorescent (TtW!), 4-27  
 12 VDC, Tek-Tron 12VDC compact fluorescent (TtW!), 41-82  
 120 vac, compact fluorescent comparison, 20-15  
 120 vac, compact fluorescent comparison, DC lights, 16-27  
 120 vac, compact fluorescents, description of, 20-20  
 120 vac, incandescent vs. fluorescent, on inverters, 3-41  
 basics, incandescent vs. halogen vs. fluorescent, ac vs. DC, 9-20  
 efficiency, retrofit of school w/fluorescents, 32-38  
 halogen, GE's Halogen-IR™ PAR 38 (TtW!), 38-76



**Lighting continued**

- health & environmental, effects of, 30-32
- Homebrew, 12 VDC night light, 23-70
- Homebrew, 120 vac LED night light, Morris, 53-32
- Homebrew, convert 120vac halogen lamp to 12VDC, 35-30
- Homebrew, convert ac lamp to 12VDC quartz halogen, 18-47
- homebrew, variable DC timer, 54-44
- International, PV, Pumping, Zaiken, 102 Wp, 12V L-A, Costa Rica, 51-6
- PV-powered, LED light (TtW!), 57-74

**Linear Current Boosters**

- pumps, how to run 24V pump w/48V battery, 40-70
- basics, how transformers and LCBs work, 37-40
- basics, using, 6-12
- DC-DC converters, long distance power transmission, 28-34
- hydro, with PM generators, 17-39
- photovoltaics, Kuff, 472 Wp, 12 V L-A. LCB, 700 ft from PV to battery, 25-16
- Things that Work!, Bobier's LCB 40, 29-53
- Things that Work!, LCB 3-4-8 for Water Pumping, 12-19

**Maximum power point tracking**

- see "Controls, maximum power point tracking", 29-34

**Methane**

- air collector, passive batch water heater, 17-19
- animal treatment, retaining heat, 27-44
- basics, low-pressure storage tank, 26-24
- chemistry, pH balance, heat, 28-39
- digester, improvements to , 40-82
- tank insulation, heat, raw material requirements, 30-42

**Motors**

- basics, how electric motors work, 34-48
- Homebrew, soft-starting, 23-72

**Multimeters**

- see "Instrumentation, multimeters"

**National Electric Code**

- and inspector, 33-76
- and UL Standards, photovoltaics, conduit, overcurrent devices (see HP44&45), 43-88
- basics, 8-27
- batteries, UL listed flexible battery cables, 41-84
- battery, battery safety, 40-94
- Book Review: Code Check, A Field Guide to Building a Safe House, 56-92
- cable ampacity, using the proper size and type of wire/cable, 37-93
- changes for 1996 code, 36-75
- Code Corner, disconnects, 19-42
- Code Corner, disconnects, 21-53
- Code Corner, grounding/isolation, 25-65
- Code Corner, grounding/overcurrent protection/fuses, 16-31
- Code Corner, history, relevance to PV, 20-54
- Code Corner, law, relation to, 23-74
- Code Corner, load circuits/wiring, 22-68
- Code Corner, safety and PV-powered pumping, 26-57
- Code Corner, surge and lightning protection, 32-68
- conductors, 31-74
- Disconnects, Code Corner, 53-72
- disconnects, required for ac and DC systems, PV, wind, generator, 42-78
- grounding, basics, 18-26
- grounding, guidelines, 25-42
- grounding, how to, 28-46
- grounding, inverter grounding, 30-64
- grounding, inverter grounding, 34-85
- grounding, why ground, 27-47
- photovoltaics, example systems: stand-alone and grid-tied, 47-84
- photovoltaics, small stand-alone systems, examples, 46-84
- short circuit protection for wiring, 38-85
- standards, 35-87
- SWRES Research, 13-42
- UL listings, appliances, system components, etc., 56-82
- water, pumping systems with PV, 45-66

**Pedal power**

- basics, 23-48
- bicycle-powered generation, track stand conversion, 56-75
- bicycle power assist, ZAP Power System, 43-46
- bicycle, with solar and electric (photo), 46-56
- charging batteries, 31-50
- human energy converter (HEC), bicycle parts + people = power, 1036 Wp, 24 V, 43-78

**Pedal power continued**

- human energy converter (HEC), use at energy fair, photo, 47-4
- photovoltaics, Haaren/Abbott, 36 W, PV: 65 Wp, 12 V L-A, 12-13
- Rail biking, 54-60

**People**

- Allart Ligtenberg, promoter of solar cooking in Nepal, 45-24
- apprentice program, letters, 42-106
- Bill Gates, with photovoltaics, 45-65
- condensed resumes, Get a Job! column, 43-106
- Dennis Ramsey, installer of PV in Nepal monasteries, 45-6
- Elliott Bayly, founder, World Power Technologies (wind generators), 43-58
- environmental community, letters (see brainstorming), 42-101
- kids, planetary citizens, amateur radio, 5-5
- Larry Schussler of Sun Frost, interview, 25-22
- pen pals, New Zealand (Letters), 43-99
- Redwood Alliance, profile of an organization, 12-22
- Sol Sisters, renewable energy networking, 19-55
- Uncle Len, Power of Personal Resourcefulness, 3-13
- university students, CCAT needs upgrade/donations, 43-70
- women, lifestyle with renewable energy, 21-40
- women, renewable energy networking, Sol Sisters, 19-55

**Photovoltaics**

- & Wind, on sailboat, Cotterell, 53-12
- ancient PV panel (TtW!), 10-31
- Ask NREL, breakthrough in low cost efficient PV, 40-98
- Ask NREL, differences in PV technologies, 39-84
- Ask NREL, Why are pv modules blue?, 38-88
- Back To Basics, run a stereo on battery & solar power, 40-104
- basics, how they work, 20-31
- basics, how they work, physics of, 23-37
- basics, number of cells per panel, 3-9
- basics, solar/hydro/wind site survey, 21-75
- batteries, charging small NiCds, 19-18
- Boat Lift , 57-50
- Book Review, Types, construction, how they work, 50-76
- Carrizo Copper Quadlams (TtW!), 39-71
- concentrators, 19-27
- concentrators, hybrid PV/hot air linear concentrator, 5-14
- concentrators, Midway PV concentrators, 40-28
- control, Heliotrope CC120E 120 Amp (TtW!), 48-36
- diodes, bypass or blocking (Q&A), 46-106
- education, PV, batteies, loads (teaching plan, part 2) , 15-5
- education, solar battery charging (teaching plan, part 1), 16-14
- education, workshops, MREA, 47-74
- electric vehicles, PV-powered sailboat, 57-28
- energy to produce cells vs. energy produced by cells, 43-73
- event, 3072 Wp, 24V, 14,000AH L-A concert system, 51-22
- Generator/systems, Yago, 2.4 Kwp, 24V, 7Kw generator, 50-32
- Homebrew, solar sight (sun's path for winter), 28-61
- Homebrew, SunSighter (point panels to sun), 26-73
- installation, Backwoods Solar Electric PV Rack (TtW!), 11-41
- installation, Echolite PV mounting brackets (TtW!), 12-31
- installation, installing/wiring/mounting, 2-11
- installation, mounting and junction box comparison, 33-22
- installation, racks, metal choices, construction, 22-41
- installation, setting optimum angle, discussion, 36-14
- installation, wiring non-identical panels, 27-22
- International, lighting, Pumping, Zaiken, 420 Wp, 12V L-A, health clinic, Costa Rica, 51-6
- international, PV in rural Chinese village, 41-32
- international, solar in Eastern Africa, 41-20
- intertie, EVs, Heckerroth, 3 Kw, 24V L-A, intertie, 50-57
- IPP/editorial, National PV Production Statistics, 51-82
- Lighting, PV- powered LED light (TtW!) , 57-74
- minisystem, for charging tools (Q&A), 43-108
- mobile ham shack, Bosbach, 86 Wp, 12V L-A, 50-38
- on VW bus, , 54-16
- panel design, construction of a PV module to power a racecar, 37-52
- pond aeration, 23-42
- procurement manual, for municipalities, utilities, other purchasers; Code Corner, 44-66
- pumps, basics, 11-15
- pumps, deep wells, 6-27
- pumps, intro to, 5-21
- repairing glass, 21-12
- run a stereo on battery & solar power, 40-104
- Siting & mounting, PV panels, 57-32
- Sovonics panel (TtW!), 15-33
- system design, basics (simple starter system), 25-48
- system design, ecomonics for home power systems, 20-39

## Photovoltaics continued

system design, economics for home power systems, 1-11  
 system design, Solar Pathfinder (TtW!), 16-44  
 system design, solar/hydro/wind site survey, 21-75  
 system, grid-intertie hybrid, 42-6  
 System, Pfeiderer, 763 Wp, 24V L-A, in Hawaii, 49-14  
 system, ski hut PV systems in Colorado, 50-24  
 system, urban, Whitaker, 100 Wp, 12 V L-A, 48-22  
 system, Waggoner, 980 Wp, 24V L-A, 51-28  
 System/Utility, Gastrow, 888Wp, 24V L-A, 52-6  
 System/Utility, Sharp, 340 Wp, 24V L-A, SEI installed, 49-6  
 Systems PV/Wind, Whitehead, 53-6  
 systems, Buck, 371 Wp, 12 V L-A, 48-6  
 systems, Epstein (OR), 2,000 Wp, 24 V L-A, 44-6  
 Systems, Fire Station, 57-12  
 Systems, FM radio station, 54-6  
 Systems, Frost, 55-44  
 systems, Haeme (shop, trailer); 360 Wp, 12 V L-A; gen 4000 W; grid, 47-24  
 systems, LaForge, 2 PV systems—w/power sheds, 40-6  
 systems, Millsapps, integrating PV with Utility Power, 39-6  
 systems, Nekola (IL), 100 Wp, 12 V L-A; wind 500 W; grid, urban, 46-6  
 systems, Nepal monasteries (2), 100 Wp, 12 V L-A, 45-6  
 Systems, on a budget, Krush, 54-22  
 Systems, recreational vehicle, Magleby, 53-24  
 systems, Reichenbach; DC: M78s, QuadLams, 6 V L-A; ac: M75s, 42-18  
 systems, Schultze, tracked array, PV/wind/hydro/DHW, 41-6  
 systems, Siebert (CA), 1122 Wp, grid, 45-18  
 Systems, Spain, Zirkel, 56-26  
 Systems, update, Nepal, Ramsey, 56-56  
 Systems, upgrade, Brethorst, 55-50  
 Systems, w/ Hydro, Wind, BLM historical site, Bethea, 55-6  
 Systems, w/ wind & passive solar, Vogel, 56-6  
 Systems, w/ Wind, small scale, 57-6  
 Systems, w/ with (re-install), in CO, Preston, 58-6  
 systems, Wausau WI, 600 Wp, 24 V L-A, 48-16  
 systems, Wheeler, PV observatory & home for \$7100, 39-14  
 systems/Urban, Gerosa, 85Wp, 12V L-A, 49-40  
 testing and rating, Hoxan PV Test Erratum, 26-69  
 testing and rating, Hoxan, 25-70  
 testing and rating, meaning, 23-40  
 testing and rating, procedure, 23-20  
 testing and rating, summer PV performance, 24-26  
 testing and rating, winter PV performance, 33-17  
 testing, hot weather performance test, HPs Democracy rack, 49-28  
 Things that Work!, Carrizo Copper Quadlams, 39-71  
 tracking, Midway PV concentrators, 40-28  
 tracking, Wallin, PV system/Wattsun tracker in MT, 40-14  
 UL Standards, National Electrical Code, 43-88  
 utilities, subsidies, Independent Power Providers (IPP), 43-74  
 Utility intertie, Colorado's Public Service Co, 18 Kw, intertie, 51-36  
 Water pumping, mobile, PV jack pump, cattle watering, 54-12  
 water, pumping systems, National Electrical Code, 45-66  
 wind hybrid, basics of wind, wind/PV hybrid, PURPA, 22-18

## Power Politics

also see, "Utilities", 44-58  
 call to put solar on White House, 34-83  
 Chernobyl, Dangers of nuclear, 53-76  
 Coalitions, Lobbying for our side, 58-86  
 Corporations, ethics, 57-86  
 editorial, getting your message to the media & government, 51-90  
 editorial, why energy should be a presidential issue, 52-90  
 energy trends, global warming, NAFTA, 38-68  
 legislation, deregulation, 43-82  
 legislation, effects of subsidies, 37-85  
 legislation, funding renewables, bogus bill ("job creation"), 47-88  
 legislation, NAFTA, RE & environment, 39-86  
 legislation, national energy bill, 32-72  
 legislation, net metering/billing, 46-72  
 letter to put solar on the White House, 35-86  
 net billing, definition(s), 46-72  
 net billing, info sources, 47-88  
 net billing, utility deregulation, 48-78  
 nuclear, & the energy budget, 40-100  
 nuclear, human experiments, security risk, NRC positions open, 42-84  
 nuclear, sites "recycled" to solar sites, 41-87  
 nuclear, waste on reservation, 47-88  
 nuclear, waste policy legislation, 46-88  
 opportunities, Clinton appointees, 33-73  
 Ralph Nader, for prez, 55-88

## Power Politics continued

rate-based incentives, definition of term, networking, 46-88  
 rate-based incentives, how-to, 44-71  
 rate-based incentives, program to implement, 45-72  
 Utilities, rate based incentives, 49-89  
 Utilities, restructuring in California, 50-90  
 Utility restructuring, in CA, 56-86  
 voting, get out the vote, 30-38  
 voting, review of presidential candidates, 31-46  
 Wisconsin, Renewables at work, 54-86

## Pumps

ac vs DC, choosing a water pump, 40-78  
 ac, submersible, inverter powered, 17-25  
 basics, types, terms defined, system design, complete info, 46-24  
 DC, submersible booster pumps & pressure tanks, 39-20  
 DC, submersible installation, 38-22  
 DC, submersible, PV-powered, Econsub Pump (TtW!), 13-22  
 DC, submersible, PV-powered, installation, 31-17  
 drilling a water well, 33-54  
 High Lifter water pump (TtW!), 23-58  
 homebrew, shallow well (letters), 43-99  
 International, PV, lighting, Zaiken, 102 Wp, 12V L-A, Costa Rica, 51-6  
 linear current boosters, how to run 24V pump w/48V battery, DC-DC converters, 40-70  
 linear current boosters, LCB 3-4-8 for Water Pumping (TtW!), 12-19  
 Photovoltaic water pumping, Dominican Republic, 56-16  
 photovoltaics, basics, 11-15  
 photovoltaics, deep wells, 6-27  
 photovoltaics, intro to, 5-21  
 PV jack pump, mobile, cattle watering, 54-12  
 ram, Ciotti, 816 Wp, 12 V NiCd, Clivus Multrum, 28-11  
 ram, Folk Ram Pumps (TtW!), 40-44  
 ram, Homebrew, hydraulic ram pump, 41-74  
 ram, RIFE ram pump, water-powered, 37-6  
 safety, NEC and PV-powered pumping, 26-57  
 Solar Slowpump (TtW!) (DC, ac available), 42-70  
 Water pumping, PV & wind, for livestock, 57-24  
 wiring, troubleshooting, 42-93

## Radiant heat barriers

see "Space heating"

## Radio

amateur, basics, history, rules, 5-31  
 amateur, communications in the country, 2-16  
 amateur, getting started, 33-65  
 amateur, HP Hams for NASA Experiment, 26-74  
 amateur, PV powered Ham station, 33-62  
 antenna, The Select-A-Tenna (TtW!), 18-28  
 antenna, TV/FM antennas, 11-25  
 basics, remote communication options, 56-42  
 Citizens Band, antennas/coaxial cable, 3-36  
 Consci Portable Power Pack (TtW!), 42-74  
 education, amateur radio, planetary citizens, 5-5  
 education, amateur radio, PV, Boy Scouts, 32-71  
 HP's radio telephone system, , 56-50  
 improving reception, inverters, antennas (Q&A-Radio Help), 42-107  
 inverters, reducing interference, 43-107  
 Photovoltaics, FM radio station, 54-6  
 photovoltaics, portable charging, 38-32  
 photovoltaics, solar-powered FM station, 43-107  
 RFI-free lighting, LED Illuminators (TtW!), 44-33  
 Sangean ATS-803A AM/FM/SW Radio Receiver (TtW!), 19-47  
 wind, world's only wind-powered station, 43-58

## Radiotelephone

see "Telephone, radiotelephone"

## Recreational Vehicles

Photovoltaics, Magleby, 53-24  
 Photovoltaics, on VW bus, 54-16  
 book reviews, Electric Burro On The Road To Bogota (travel), 18-49  
 photovoltaics, at camp ground, 258 Wp, 12 V L-A, 20-12  
 photovoltaics, Gilbert, motorhome, 750 Wp, 12 V L-A, 24-40  
 photovoltaics, Haeme (trailer); PV 360 Wp, 12 V L-A; gen 4000 W; grid, 47-24  
 photovoltaics, travel trailer system for under \$2000, 38-12  
 space heating, hydronic heating system, 26-53

## Refrigeration

Homebrew, 12 Volt chest-type, 38-9  
 Homebrew, DC refrigerator/freezer, 21-8  
 Homebrew, DC refrigerator/freezer, insulation, 16-48  
 ice farming, 21-66  
 international, PV refrigerators in South America, 21-20

**Refrigeration continued**

modifications, energy conservation in refrigerators (letters), 44-84  
 refrigerators, Sun Frost RF-19 refrigerator/freezer (TtW!), 45-34  
 safety, gas appliances, 24-67  
 Solar thermal, ammonia absorption ice maker, Vanek & Green, 53-20  
 Sun Frost power usage, letters, 42-104  
 Sun Frost, Home & Heart, seeds, 26-75  
 Sun Frost, Larry Schussler interview, 25-22  
 Sun Frost, Sun Frost RF-12 Refrigerator/Freezer (TtW!), 5-33

**Regulators**

3 terminal adjustable voltage (TtW!), 6-37  
 Backwoods Solar's PV controller (TtW!), 7-34  
 DC-DC converters, long distance power transmission for, 28-34  
 Enermaxer voltage regulator, 7-19  
 Heliotrope CC-20 charge controller (TtW!), 13-36  
 Heliotrope CC-60 charge controller (TtW!), 8-31  
 Homebrew, "latchup" shunt voltage regulator, 25-74  
 Homebrew, DC power supply converter, 29-69  
 Homebrew, electronic field controller v.8.3, engine/generator, 42-28  
 Homebrew, NiCd battery charger wall cube replacement, 26-72  
 Homebrew, power point regulator to run motor from PVs, 38-72  
 Homebrew, PV direct regulator, 32-46  
 Homebrew, run a stereo on battery & solar power, Back to Basics, 40-105  
 Homebrew, short circuit 35 Amp regulator, 28-57  
 Homebrew, shunt regulator, 18-46  
 SunAmp Power Co's PV regulator (TtW!), 19-48

**Safety**

Ananda's 400 Amp Safety Switch (TtW!), 27-58  
 Ananda's Power Center IV (TtW!), 29-56  
 basics, National Electrical Code (NEC), 8-27  
 batteries, battery/inverter fused disconnects, circuit resistance, 21-47  
 batteries, overcurrent protection devices, 27-26  
 batteries, short circuit protection, 17-37  
 batteries, tech notes, 27-69  
 Care-Cover 120 vac outlet covers (TtW!), 10-33  
 Chernobyl, Dangers of nuclear, Power Politics, 53-76  
 Code Corner, lightning protection, 57-82  
 Disconnects, Code Corner, 53-72  
 disconnects, Code Corner, NEC, 19-42  
 disconnects, required for ac and DC systems, PV, wind, generator, 42-78  
 electric vehicles, safety disconnects, circuit breakers, fuses, 38-60  
 electric vehicles, safety features for the EV conversion, 50-68  
 electric vehicles, safety in races, 30-22  
 EVs, design, operation & maintenance, 51-58  
 gas appliances, refrigerators, 24-67  
 grounding, and lightning protection, 6-16  
 grounding, basics, NEC, 18-26  
 grounding, guidelines, 25-42  
 grounding, isolation, NEC, 25-65  
 grounding, why ground, NEC, 27-47  
 inverters, battery/inverter fused disconnects, circuit resistance, 21-47  
 inverters, fuses for/wiring protection, 24-66  
 isolation, grounding, National Electrical Code, 25-65  
 Lightning Arrestors, , 55-72  
 Lightning on Agate Flat, Muddy Roads, 55-68  
 photovoltaics, grounding/overcurrent protection/fuses, NEC, 16-31  
 pumps, PV-powered, NEC, 26-57  
 refrigerators, gas appliances, 24-67  
 systems, basics of overcurrent protection, 29-38  
 systems, purchase of, procurement manual, specs, Code Corner, 44-66  
 wind, lightning protection/grounding, 24-53  
 Wind, towers, safety & maintenance, 57-18  
 wiring ALERT, Code Corner, ac multiwire branch circuits, 54-82  
 wiring, 12/24 Volt, plugs, NEC, 7-27  
 wiring, connections, splicing, 14-36

**Sanitation**

composting toilet, Clivus Multrum, Ciotti, 816 Wp, 12 V NiCd, ram pump, 28-11  
 greywater, composting toilet, CCAT, PV: 450 Wp, 12 V L-A. Wind: 500 W, 32-6

**Sewing machines**

conversion, electric to treadle, 18-48  
 Homebrew, converting electric to hand-powered, 17-59

**Shunts**

see "Instrumentation, shunts"

**Solar cooking**

Capturing Heat, book review, five cooker designs , 55-99  
 Education, for kids, Home & Heart, 57-90  
 Peru, , 57-44  
 backpacking, lightweight cooker, 45-24  
 basics, history, 7-15  
 basics, how the geometry of light affects design, 39-78  
 book reviews, Heaven's Flame, 19-52  
 book reviews, Morning Hill Cookbook (Home & Heart), 47-92  
 conference, '92 World Solar Cooking Conference, 31-64  
 contests, HP 1992 cooker contest results, 31-38  
 contests, HP 1993 cooker contest results, 37-22  
 contests, HP 1994 cooker contest results, 43-33  
 crafts, use of Fresnel lenses and Solar Chef cooker (Q&A), 44-91  
 education, Kid's Corner: solar cooker design, 27-74  
 education, Kid's Corner: solar oven design, 30-74  
 education, Spanish-language pamphlet to build cooker, 44-50  
 Homebrew, 1994 cooker contest winner plans, 43-33  
 Homebrew, Box Cookers, 12-14  
 Homebrew, HP 1992 cooker contest results, 31-38  
 homebrew, lightweight cooker for backpacking, 45-24  
 Homebrew, parabolic, "Berkeley Thermonuclear Paraboloid", 37-34  
 international, Chile, how solar cooking changed a village, 41-28  
 international, Nepal, work with org's by Allart Ligtenberg, backpacking, 45-24  
 international, Peru, pamplet to teach construction/use of cooker (Spanish), 44-50  
 recipes, 20-29  
 recipes, Home & Heart, 41-95  
 resources, box cookers, 9-36  
 SBCI's Solar Cooker Kit (TtW!), 29-60  
 Solar Chef, solar cooker extraordinaire, 44-74  
 Solar Gourmet solar cooker kit (TtW!), 24-59  
 Sun Oven (TtW!), 19-44

**Solar distillation**

See "Water"

**Solar Food Drying**

Homebrew, food dryer concepts & plans , 57-62  
 Home & Heart, experiences, 30-75  
 Homebrew, arid climates how-to, 29-64  
 Homebrew, humid climates how-to, 29-62

**Solar space heating**

see "Space heating, solar"

**Solar water heating**

see "Water heating, solar"

**Soldering**

basics, how to, 18-35  
 Pensol portable gas soldering iron (TtW!), 16-39

**Space heating**

basics, radiant heat barriers, 28-43  
 degree days, explanation, chart, information source, 46-41  
 Electric heater , Thermal Art (TtW!), 54-71  
 gas furnace retrofit, 4-21  
 hydronic heating, problem solved (letters), 47-100  
 hydronic, solar, active/passive, specs, sources, etc, Gimme Shelter, 46-37  
 hydronic, solar/propane, with wood; also PVs/grid, Epstein (OR), 44-6  
 masonry heaters, with bake oven, 4000 lbs, backup for solar, sources, etc, 46-37  
 Passive Solar, Sun room add-on, Sexton, 53-16  
 RV, hydronic heating system, 26-53  
 solar, active/passive, whole-house, sources, etc, Gimme Shelter, 46-37  
 solar, air & liquid collectors, basic types, also water heating, 40-36  
 solar, air collector, passive batch water heater, methane gas, 17-19  
 solar, glass and glazing choices, 30-26  
 solar, how hot air collectors work, 25-53  
 solar, hybrid PV/hot air linear concentrator, 5-14  
 solar, storage systems, diagrams, also water heating, 42-66  
 solar, unspace, trombe wall, radiant floor heat, direct gain, 32-28  
 solar, unglazed transpired collector (letters), 43-101  
 system, hydronic space heating in Wisconsin, 49-43  
 systems, W/ PV, Wind, & passive solar, Vogel, 56-6  
 wood, radiant floor system, Simko, Whisper 1000, PV: 288 Wp, 36 V., 36-18  
 wood, Simko; also wind, Whisper 1000; PV: 288 Wp, 36 V., 36-18  
 wood, with hydronic, passive solar, PVs/grid, Epstein (OR), 44-6

**Steam**

how to, safety of, 21-55  
 sources, (letters), 46-102

## System design

12V to 24V conversion, 41-16  
 basics, An Introduction To The Basics, 21-67  
 basics, concepts of system design, overview, 40-72  
 basics, Efficient, Low Cost, Reliable Systems, 12-10  
 basics, site survey, solar, hydro, and wind, 21-75  
 basics, size, costs, batteries, inverters, PVs, hydro, wind, 22-59  
 basics, sizing, how to figure energy use, 27-71  
 basics, The Integrated Energy System, 3-6  
 book review, collection of RE product spec sheets, over 200 pgs, 50-76  
 conservation, appliance choices, 21-68  
 conservation, appliances, finding phantom loads, 14-13  
 conservation, heat, 10-21  
 controls, voltage sensing switch, charger to grid at low battery volts, 46-106  
 disconnects, required for ac and DC systems, PV, wind, generator, 42-78  
 education, workshops, MREA, 47-74  
 how to figure energy use, 27-71  
 hydro siting, for nano-hydro, 15-17  
 hydro siting, how to, weir measurement table, 8-17  
 hydro siting, overview, system, 1-7  
 Load analysis, 58-38  
 National Electrical Code, Stand-Alone PV with Generator Back-up, 48-47  
 photovoltaics, basics (simple starter system), 25-48  
 photovoltaics, economics for home power systems, 1-11  
 photovoltaics, sizing PV power and battery, 32-78  
 PV/NEC, Designing systems to meet code, 50-86  
 Siting & mounting, PV panels, 57-32  
 sizing components for photovoltaic/generator system, 4-44  
 sizing PV power and battery, 32-78  
 tech notes, installer tips, 33-78  
 voltage, sizing system voltage, 4-12  
 voltage, sizing system voltage, 5-12  
 water, complete info, pump types, terms defined, 46-24  
 wind, generators, 14 compared/table/graphs, glossary of terms, 47-36  
 wind, siting, 1-16  
 wiring, DC sizing table, voltage drop, applications, 14-32  
 wiring, DC sizing table, voltage drop, apps (correct in #14), 13-32

## Systems

conservation, in the city, 22-11  
 emergency, micro system: Sovonics PV, Ovonics battery(TiW!), 15-33  
 emergency, micropower system, 14-9  
 emergency, power system, 25-33  
 emergency, temporary, "shorties", also wind, photovoltaics, generators, 17-46  
 emergency, use after fire, photovoltaics on temporary housing, 34-37  
 generators, see "photovoltaics/generators", "wind/generators", etc.  
 hydro, 120 vac, 13 ft. overshot water wheel, 37-6  
 hydro, basics and overview, 44-24  
 hydro, Gaydos, Hydrocharger: 40 ft/8 gpm; PV: 50 Wp, 11-5  
 hydro, Higgs, Morgan-Smith turbine, 17 ft head/ 10,000 gpm , 25-7  
 hydro, Independent P&L, 210 ft/25 gpm; PV: 1450 Wp, tracker, 17-6  
 hydro, Kennedy Creek & S systems, high head, 100 to 2200 watts, 20-7  
 hydro, Kinzel/Kingsley (MI); 16ft/75gpm, FAT, 12V L-A; PV 480 Wp, 47-16  
 hydro, Nicaragua, 78 ft/160 gpm, 12 V lead-acid, 8-13  
 hydro, Purcell Lodge, IPD pelton, 315 ft head/ 220 gpm, 12 kW, 33-12  
 hydro, Rakfeldt, Harris turbine, 300 ft/400 gpm, 24 V, 6-5  
 hydro, Schultze, homestead; photovoltaics, wind, solar hot water, 41-6  
 hydro, Spencer, living with Lil Otto in Australia, 52-40  
 Hydro/Homebrew, Gima & Puttre, dirt cheap hydro, 66Wp, 12V L-A, 52-14  
 hydro/photovoltaics, Gaydos, Hydrocharger, 40 ft/8 gpm. 50 Wp PV, 11-5  
 hydro/photovoltaics, Lil Otto hydroworks, 40 ft/ 9 gpm, PV: 168 Wp, 15-14  
 hydro/photovoltaics, Schultze, homestead; wind, solar hot water, 41-6  
 hydro/photovoltaics/trackers, Independent P&L, 210 ft/25 gpm, PV: 1450 Wp, 17-6  
 hydrogen, Pyle, et al, home-sized solar hydrogen project, 39-32  
 international, Amazon, Yacumama Lodge, PV: 576 Wp, 24 V L-A; generator, 43-6  
 international, Chatuco, PV: 960 Wp 24 V L-A, 10-5  
 international, Colombia, PV: 612 Wp, 12 V nickel-iron, 32-99  
 international, El Salvador, PV and solar ovens, 35-58  
 international, El Salvador, PVs in, 31-28  
 international, Guyana, PV powered health care, 20-37  
 international, Honduras, Central America, PV, 34-14

## Systems continued

international, Nepal monasteries (2), 100 Wp, 12 V L-A, 45-6  
 international, New Zealand, Soma 300 W, PV/wind hybrid economics, 18-21  
 International, PV, Pumping, Zaiken, 420 Wp, 12V L-A, health clinic, Costa Rica, 51-6  
 International, PV, Wind & Hydro systems in New Zealand, 49-36  
 International, SELFs Solar Electricity for Rural Women, 50-6  
 international, South America, PV refrigerators, 21-20  
 international, Sri Lanka, PV, 37-19  
 international, Vietnam, PV for medical clinic, 38-46  
 maintenance, preparing for winter, 14-7  
 ownership, independent or utility?, Independent Power Providers, 44-58  
 pedal power, basics, 23-48  
 pedal power, pedal powered charging, 31-50  
 pedal power/photovoltaics, Haaren/Abbott, 36 W, PV: 65 Wp, 12 V L-A, 12-13  
 Photovoltaic water pumping, Dominican Republic, 56-16  
 Photovoltaic, EVs, Heckerroth, 3 Kw, 24V L-A, intertie, 50-57  
 Photovoltaic, upgrade, Brethorst, 55-50  
 photovoltaic, Yago, 2.4 kWp, 24 V, 7Kw generator, 50-32  
 Photovoltaic/mobile ham shack, Bosbach, 86 Wp, 12V L-A, 50-38  
 photovoltaic/wind, Nekola (IL); PV 100 Wp, 12 V L-A; wind 500 W; grid, urban, 46-6  
 Photovoltaics update, Nepal, Ramsey, 56-56  
 photovoltaics, "shorties", 19-49  
 photovoltaics, "shorties", also wind, generators, temporary, 17-46  
 photovoltaics, "shorties", also wind, solar hot water, rainwater, cogen, 20-50  
 photovoltaics, "shorties", on a budget, also wind, 18-44  
 photovoltaics, Ananda, powers 4 homes, 6600 Wp, 24 V, 24-14  
 photovoltaics, Andrews, 96 Wp, 12 V L-A, 13-5  
 photovoltaics, Battagin, 204 Wp, 24 V L-A, solar welding, manual tracker, 33-6  
 photovoltaics, Bridges, 470 Wp 12 V L-A, solar hot water, 12-5  
 photovoltaics, Burckhard, 1250 Wp, 24 V lead acid, 29-18  
 photovoltaics, CCAT need for upgrade, 43-70  
 photovoltaics, CCAT, 450 Wp, 12 V L-A; wind: 500 W; greywater, 32-6  
 photovoltaics, Chase, 658 Wp, 12 V lead-acid, 31-6  
 photovoltaics, Ciotti, 816 Wp, 12 V NiCd, ram pump, Clivus Multrum, 28-6  
 photovoltaics, Cook, 2560 Wp, 120 V, wind: Northern Power 3.5 kW, 29-6  
 photovoltaics, Cunningham, earth-sheltered dome, wind water pumping, 38-6  
 photovoltaics, Davenport, 320 Wp, 12 V L-A; wind: 200 W Wincharger; refrig, 21-8  
 photovoltaics, Drake, 700 Wp, 12 V L-A, 21-6  
 photovoltaics, Elliot, machine shop & home, wind, grid back-up, 38-16  
 photovoltaics, Epstein (OR), 2,000 Wp, 24 V L-A, 44-6  
 photovoltaics, Fire Station, 57-12  
 photovoltaics, Flett, 384 Wp, 12 V L-A, 13-7  
 photovoltaics, FM radio station, 54-6  
 photovoltaics, Frost, 55-44  
 photovoltaics, Gaydos, PV: 50 Wp; Hydrocharger: 40 ft/8 gpm, 11-5  
 photovoltaics, generators, see "Systems, photovoltaics/generators"  
 photovoltaics, Gilbert, motorhome, 750 Wp, 12 V L-A, 24-40  
 photovoltaics, Haaren/Abbott, 36 W, PV: 65 Wp, 12 V L-A, 12-13  
 photovoltaics, Haeme (shop, trailer); 360 Wp, 12 V L-A; gen 4000 W; grid, 47-24  
 photovoltaics, Hawes, straw bale home, PV: 408 Wp, 12 V L-A, 35-62  
 photovoltaics, hermit power box, portable, 48 Wp, 12 V nicad, 28-16  
 photovoltaics, Hodgdon & Burgess, 200 Wp, ac sub pump, 23-12  
 photovoltaics, Hoffman, 228 Wp, 12 V L-A, 7-5  
 photovoltaics, Home Power, 1400 Wp, wind: 800 W Survivor, 12 V nicad, 30-101  
 photovoltaics, Home Power, 155 Wp, 12 V L-A, 7-9  
 photovoltaics, Home Power, 400 Wp, 12 L-A, 16-7  
 photovoltaics, Hydro, Wind, BLM historical site, Bethea, 55-6  
 photovoltaics, in garden cart, portable, 105 Wp, 12 V L-A, 29-14  
 photovoltaics, Independent P&L, PV: 1450Wp, tracker; hydro 210ft/25gpm, 17-6  
 photovoltaics, Kingman (CA); PV 848 Wp, 24 V N-I; gen 7.5kW propane, 46-16  
 photovoltaics, Kuff, 472 Wp, 12 V L-A. LCB, 700 ft from PV to battery, 25-16  
 photovoltaics, LaChapelle & Hunt, 400 Wp, 12 V L-A, 17-13  
 photovoltaics, LaForge, 2 PV systems—w/power sheds, 40-6  
 photovoltaics, Lasley (OR), 146 Wp, 12 V L-A, generator, 44-16  
 photovoltaics, Linn, 880 Wp; homemade wind, 24 V NiCd, 26-16  
 photovoltaics, Markatos, dome, 735 Wp, 12 V lead-calcium gel, 32-14

**Systems continued**

photovoltaics, McCoy & Reising, 360 Wp, 12 V L-A, passive solar, rain pond, 24-6  
 photovoltaics, Millard, 1300 Wp, tracker; wind: Electro 6 kW, 10-17  
 photovoltaics, Millsapps, integrating PV with Utility Power, 39-6  
 photovoltaics, Murray, 400 Wp, 12 V L-A, tracker, 9-5  
 photovoltaics, Nekola (IL), 100 Wp, 12 V L-A; wind 500 W; grid, urban, 46-6  
 photovoltaics, Nepal monasteries (2), 100 Wp, 12 V L-A, 45-6  
 photovoltaics, O'Neal & Fiore, small system in the city, 37-13  
 Photovoltaics, on a budget, Krush, 54-22  
 photovoltaics, on cart, portable, 10 Wp, 12 V, 31-22  
 photovoltaics, on sailboat, Oldfield, also wind, 18-16  
 photovoltaics, Phelps, 576 Wp, 24 V L-A, 24-22  
 photovoltaics, pond aeration, 23-42  
 photovoltaics, portable , on cart, 10 Wp, 12 V, 31-22  
 photovoltaics, portable charging, small computer or radio, 38-32  
 photovoltaics, portable, charging small batteries for radio, 33-68  
 photovoltaics, portable, hermit power box, 48 Wp, 12 V nicad, 28-16  
 photovoltaics, portable, in garden cart, 105 Wp, 12 V L-A, 29-14  
 photovoltaics, portable, Voltar, in pickup, tracker, 945 Wp, 28-30  
 photovoltaics, portable, Yoder, juicer business, 65 Wp, 12 V L-A, 35-14  
 photovoltaics, power center for 1 PV, 1 battery system, 34-93  
 photovoltaics, Rassman, 370 Wp, 342 V L-A; wind: 2.8 kW Jacobs, 11-9  
 photovoltaics, recreational vehicle at camp ground, 258 Wp, 12 V L-A, 20-12  
 Photovoltaics, Recreational Vehicle, Magleby, 53-24  
 photovoltaics, Reichenbach; DC: M78s, QuadLams, 6 V L-A; ac: M75s, 42-18  
 photovoltaics, Robishaw & Schmeck, 140 Wp, 12 V L-A + NiCds, earth bermed, 35-6  
 photovoltaics, Rook, 714 Wp, 24 V NiCd, log cabin, 27-6  
 photovoltaics, Sailer, 768 Wp, 6 V L-A, 42-6  
 photovoltaics, Schatz experimental PV/hydrogen, 22-26  
 photovoltaics, Schultze, homestead; wind, hydro, solar water heating, 41-6  
 photovoltaics, SEI, stand alone, 450 Wp, 12 V NiCd, 26-6  
 photovoltaics, Siebert (CA), 1122 Wp, grid, 45-18  
 photovoltaics, Simko, 288 Wp, 36 V; solar hot water; wind: Whisper 1000, 36-18  
 Photovoltaics, ski hut PV systems in Colorado, 50-24  
 Photovoltaics, Spain, Zirkel, 56-26  
 photovoltaics, Stillman, 400 Wp, 24 V L-A, solar hot water, 22-6  
 photovoltaics, Swisher, 280 Wp, 12 V L-A; wind: 200 W Wincharger, 21-14  
 photovoltaics, The Wizard, 48 Wp, 12 V NiCd, 15-31  
 photovoltaics, tract home, Kyocera, 6372 Wp, 48 V, 325 V lead-acid, 16-35  
 photovoltaics, travel trailer system for under \$2000, 38-12  
 photovoltaics, urban, Buck, 371 Wp, 12 V L-A, 48-6  
 photovoltaics, urban, Burckhard, 1250 Wp, 24 V L-A, 29-18  
 photovoltaics, urban, CCAT, 450 Wp, 12 V L-A; wind: 500 W; greywater, 32-6  
 photovoltaics, urban, Drake, 700 Wp, 12 V L-A, 21-6  
 photovoltaics, urban, Nekola (IL), 100 Wp, 12 V L-A; wind 500 W; grid, 46-6  
 photovoltaics, urban, O'Neal & Fiore, small system in the city, 37-13  
 photovoltaics, urban, Potts, 250 Wp, 12 V L-A. economics of, 21-25  
 photovoltaics, urban, Sailer, 768 Wp, 6 V L-A, 42-6  
 photovoltaics, urban, SEI, stand alone, 450 Wp, 12 V NiCd, 26-6  
 photovoltaics, urban, Siebert (CA), 1122 Wp, grid, 45-18  
 photovoltaics, urban, Wausau WI, 600 Wp, 24 V L-A, 48-16  
 photovoltaics, urban, Whitaker, 100 Wp, 12 V L-A, 48-22  
 photovoltaics, Voltar, portable, in pickup, tracker, 945 Wp, 28-30  
 photovoltaics, Walker, 480 Wp, 12 V L-A, pump, solar hot water, 34-6  
 photovoltaics, Wallin, PV system/Wattsun tracker in MT, 40-14  
 photovoltaics, Ward, 90 Wp, 12 V lead-acid, 30-6  
 photovoltaics, Wheeler, PV observatory & home for \$7100, 39-14  
 Photovoltaics, wind, passive solar, Vogel, 56-6  
 Photovoltaics, Wind, small scale, 57-6  
 photovoltaics, Yacumama Lodge, Amazon, 576 Wp, 24 V L-A, 43-6  
 photovoltaics, Yoder, portable, juicer business, 65 Wp, 12 V L-A, 35-14  
 photovoltaics, recreational vehicles, at camp ground, 258 Wp, 12 V L-A, 20-12  
 photovoltaics, recreational vehicles, Gilbert, motorhome, 750 Wp, 12 V L-A, 24-40  
 photovoltaics, recreational vehicles, travel trailer system for under \$2000, 38-12  
 photovoltaics/generators, Haeme (shop, trailer); 360 Wp, 12 V L-A; gen 4000 W; grid, 47-24

**Systems continued**

photovoltaics/generators, Kingman (CA); PV 848 Wp, 24 V N-I; gen 7.5kW propane, 46-16  
 photovoltaics/generators, Lasley (OR); 146 Wp, 12 V L-A; gen, 44-16  
 photovoltaics/generators, Pryor, 200 Wp, 12 V L-A; generator, 2-7  
 photovoltaics/generators, Yacumama Lodge, Amazon, 576 Wp, 24 V L-A; 6.5 kW gen, 43-6  
 photovoltaics/grid, Epstein (OR), 2,000 Wp, 24 V L-A, 44-6  
 photovoltaics/grid, Haeme (shop, trailer); 360 Wp, 12 V L-A; gen 4000 W; grid, 47-24  
 photovoltaics/grid, Nekola (IL), 100 Wp, 12 V L-A; also wind 500 W; urban, 46-6  
 photovoltaics/grid, Siebert (CA), 1122 Wp, 45-18  
 photovoltaics/hydro, Gaydos, PV: 50 Wp; Hydrocharger: 40 ft/8 gpm, 11-5  
 photovoltaics/hydro, Independent P&L, PV: 1450Wp, tracker; hydro 210ft/25gpm, 17-6  
 photovoltaics/hydro, Schultze, homestead; wind, solar hot water, 41-6  
 photovoltaics/hydrogen, Schatz experimental PV/hydrogen, 22-26  
 photovoltaics/pedal power, Haaren/Abbott, 36 W, PV: 65 Wp, 12 V L-A, 12-13  
 photovoltaics/tracked, Pfleider, 763 Wp, 24V L-A in Hawaii, 49-14  
 photovoltaics/trackers, Independent P&L, PV: 1450Wp, tracker; hydro 210ft/25gpm, 17-6  
 photovoltaics/trackers, Millard, 1300 Wp, tracker; wind: Electro 6 kW, 10-17  
 photovoltaics/trackers, Murray, 400 Wp, 12 V L-A, tracker, 9-5  
 photovoltaics/trackers, Voltar, portable, in pickup, tracker, 945 Wp, 28-30  
 photovoltaics/trackers, Wallin, PV system/Wattsun tracker in MT, 40-14  
 photovoltaics/utility intertie, Elliot, machine shop & home, wind; grid back-up, 38-16  
 photovoltaics/utility intertie, Millsapps, integrating PV with Utility Power, 39-6  
 photovoltaics/wind, Cunningham, earth-sheltered dome, wind water pumping, 38-6  
 photovoltaics/wind, Elliot, machine shop & home, grid back-up, 38-16  
 photovoltaics/wind, Schultze, homestead; hydro, solar hot water, 41-6  
 Photovoltaics/Wind, Whitehead, 53-6  
 photovoltaics/wind/grid, Nekola (IL); PV 100 Wp, 12 V L-A; wind 500 W; grid, urban, 46-6  
 photovoltaics/wind/hydro/DHW, Schultze, homestead, 41-6  
 photovoltaics/wind/utility intertie, Elliot, machine shop & home, grid back-up, 38-16  
 purchase of, procurement manual, specs, Code Corner, 44-66  
 PV powered lawn mower, Knapp, 28 Wp, 12V L-A, 50-72  
 PV, sailboat, bicycle, Warnberg, low impact lifestyle, 52-60  
 PV, Waggoner, 980 Wp, 24V L-A, 51-28  
 PV/event, 3072 Wp, 24V, 14,000AH L-A concert system, 51-22  
 PV/Urban, Gerosa, 85Wp, 12V L-A, 49-40  
 PV/Utility, Gastrow, 888Wp, 24V L-A, 52-6  
 PV/Utility, Sharp, 340 W p, 24 V L-A, SEI installed, 49-6  
 PV/Wind, on sailboat, Cotterell, 53-12  
 recreational vehicles, at camp ground, photovoltaics 258 Wp, 12 V L-A, 20-12  
 recreational vehicles, Gilbert, motorhome, PV: 750 Wp, 12 V L-A, 24-40  
 recreational vehicles, PV travel trailer system for under \$2000, 38-12  
 shorties, photovoltaics, 19-49  
 shorties, photovoltaics, wind, on a budget, 18-44  
 shorties, wind, photovoltaics, generators, temporary, 17-46  
 shorties, wind, photovoltaics, solar hot water, rainwater, cogen, 20-50  
 Solar space heating, hydronic space heating in Wisconsin, 49-43  
 solar thermal, D'Angelo/CMC, water/space heating, 17-19  
 surplus wire & connectors, from local electric utility (letters), 44-86  
 utility intertie, PURPA, equipment, requirements, pros & cons, 32-25  
 utility intertie, rate systems, 33-49  
 Utility/intertied, Colorado's Public Service Co, 18 Kw, intertied, 51-36  
 Water pumping, PV & wind, for livestock, 57-24  
 wind, "shorties", also photovoltaics, generators, temporary, 17-46  
 wind, "shorties", also PV, solar hot water, rainwater, cogen, 20-50  
 wind, "shorties", on a budget, also photovoltaics, 18-44  
 Wind, in Falkland Islands, Wilkinson, 55-18  
 Wind, Islam, homebrewed, 2000W, Scotland, 52-20  
 wind, on sailboat, homemade 2 Amp wind generator, 5-9  
 wind, Otto (MN); 10 kW; grid, 47-6  
 Wind, Photovoltaics, wind re-install in CO, Preston, 58-6  
 wind, Schultze, homestead; photovoltaics, hydro, solar hot water, 41-6  
 wind/grid, Otto (MN); 10 kW, 47-6  
 wind/intertie, Berger, 4 Kw, no batteries, 51-14  
 wind/photovoltaics, Ames, Bergery 1 kW, PV: 190 Wp, 4-5

## Systems continued

- wind/photovoltaics, Cook, Northern Power 3.5 kW, PV: 2560 Wp, 120 V, , 29-6
- wind/photovoltaics, Davenport, 200 W Wincharger, PV: 320 Wp, 12 V L-A, refrig, 21-8
- wind/photovoltaics, Home Power, PV: 1400 Wp, wind: 800 W Survivor, 12 V nicad, 30-101
- wind/photovoltaics, Linn, PV: 880 Wp, homemade wind, 24 V NiCd, 26-16
- wind/photovoltaics, Millard, Electro 6 kW, PV: 1300 Wp, tracker, 10-17
- wind/photovoltaics, on sailboat, Oldfield, PV and wind, 18-16
- wind/photovoltaics, Rassman 2.8 kW Jacobs, PV: 370 Wp, 342 V L-A, 11-9
- wind/photovoltaics, Schultze, homestead; hydro, solar hot water, 41-6
- wind/photovoltaics, Simko, Whisper 1000, PV: 288 Wp, 36 V hot water, 36-18
- wind/photovoltaics, Swisher, 200 W Wincharger, PV: 280 Wp, 12 V L-A, 21-14
- wind/photovoltaics, urban, CCAT, PV: 450 Wp, 12 V L-A. Wind: 500 W. greywater, 32-6

## Telephone

- inverters, noise, 3 ways to keep buzz out of telephones, 38-78
- inverters, noise, eliminating, 42-9
- radiotelephone, affordable group system, 12-32
- radiotelephone, basics, 7-32
- radiotelephone, basics, different types and sizes, 32-34
- radiotelephone, basics, particulars, costs, sources (Q&A), 45-90
- radiotelephone, RCC and IMTS comparison, 4-29
- radiotelephone, Telemobile system (TtW!), 8-38
- radiotelephone, Telenexus Phone Line Extender, 14-35

## Thermoelectric generation

- basics, 36-47
- from gas-producing water well (letters), 47-102
- sources, (letters), 46-102

## Things that Work

- see listing under component type (TtW!)

## Trackers

- concentrating arrays, Midway PV concentrators, 40-28
- Home built gas, Systems, w/ PV, wind, & passive solar, Vogel, 56-6
- Homebrew, active, 17-48
- Homebrew, manual, 13-20
- Homebrew, manual, Battagin, 204 Wp, 24 V L-A, solar welding, 33-6
- systems, Independent P&L, PV: 1450Wp, tracker; hydro 210ft/25gpm, 17-6
- systems, Millard; PV: 1300 Wp, tracker; wind: Electro 6 kW, 10-17
- systems, Murray, 400 Wp, 12 V L-A, tracker, 9-5
- systems, Voltar, portable, in pickup, PV: 945 Wp, tracker, 28-30
- systems, Wallin, PV system/Wattsun tracker in MT, 40-14
- Wattsun PV tracker (TtW!), 25-56

## Utilities

- \$1 on utility bill for RE, 25-32
- also see, "Power Politics"
- and PV applications, 35-82
- and PV, 33-70
- and PV, ownership, Independent Power Providers (IPP), 44-58
- and PV, providers or not (letters), 42-102
- and PV, subsidies, Independent Power Providers (IPP), 43-74
- and PV, subsidies, Independent Power Providers (IPP), 46-82
- birds, power politics, 46-30
- birds, power politics, wind vs. conventional, Audubon report, 47-10
- Chernobyl, Dangers of nuclear, Power Politics, 53-76
- conservation, interties (letters), 46-100
- conspicuous consumption, Pacific Power's "houses of the future," Home & Heart, 43-93
- corporate welfare, vs. loan guarantees to end users, Independent Power Provider, 46-82
- Costs of RE, how people can affect, 57-39
- costs, hidden, of commercial power, 16-21
- deregulation, Power Politics, 43-82
- dirty power, flickering lights, ruined appliances (Q&A), 44-90
- distributed generation, (letters), 46-101
- distributed generation, need for, types, 45-65
- distributed generation, position on, Independent Power Providers (IPP), 46-82
- efficiency, of conventional power plants, Ask NREL, 45-62
- flawed surveys, Independent Power Providers (IPP), 44-58
- future of, use of hydrogen, 29-28
- grid power emissions, in terms of EV use, 56-70
- Grid, fundamentals of, , 54-34
- Intertie, Net metering in CA, NY, & OR, 56-78

## Utilities continued

- Intertie, Net Metering, IPP, 53-68
- Intertie, policies, IPP, 54-76
- Intertie, restructuring, & distributed generation , 57-78
- interties, buy-back rates, net billing (letters), 43-100
- interties, net billing, co-op vs. investor-owned, Independent Power Pro, 42-62
- interties, net metering explanation, California legislation, 46-72
- interties, Part 1, PURPA, equipment, requirements, pros & cons, 32-25
- interties, Part 2, rate systems, 33-49
- interties, pricing schedule for independent power providers, 44-13
- IPP, net metering, financing, SCE off-grid, deregulation, 49-82
- IPP/editorial, California PV for Utilities (PV4U), 50-82
- IPP/editorial, Ontrio Hdyro, CA net metering, PV growth, 52-82
- monopolies, Independent Power Providers (IPP), 47-82
- Net Metering, Summer '96 outages, restructuring, IPP, 55-76
- Power Politics, Rate based incentives, 49-89
- PV intertied, Colorado's Public Service Co, 18 Kw, intertied, 51-36
- rate-based incentives, European examples, to stimulate RE purchase/installation, 44-20
- rate-based incentives, implementation how-to, 45-72
- restructuring in California, 50-90
- Restructuring, in CA, 56-86
- satisfaction with vs. RE, HP survey results, 43-16
- SCE PV pilot termination, IPP, 58-76
- Southern California Edison, experience with by PV owner, Siebert, 45-18
- system standards, proposal (letters), Independent Power Providers (IPP), 44-83
- vs. home power, 27-18

## Vacuum cleaners

- Sanderson's rebuilt Kirby's (TtW!), 32-75

## Vegetable oil

- diesel fuel, pointers for using in cars, experiences with, 45-86

## Video Reviews

- Alternative Energy with the Experts, three videos: PV, Wind, Hydro, 56-93
- EVs & Hydrogen, 27-78
- Solar Videos, 28-74
- Video/VCR Plus device, letters (see phantom load killer), 42-105

## Voltmeters

- see "Instrumentation, voltmeters"

## Washing machines

- book reviews, Efficient Washing Machines, 23-77
- efficiency of, 23-61
- front loading, brands compared, 46-92
- front-loader, 2 praised (letters), 47-92
- Homebrew, converting a wringer washer to DC, 40-40
- readers' experiences, Home & Heart, 45-76
- retrofitting for high efficiency, 22-44
- Staber System 2000 (TtW!), 47-70
- Wattevr Works washer kit, retrofit (TtW!), 25-63

## Water

- Pumping, mobile, PV jack pump, cattle watering, 54-12
- pumps, see "Pumps"
- Solar pasteurization & distillation, for the developing world, 52-44
- sprinklers, automatic, Code Corner, safety, 44-66
- system design, complete information, terms defined, pump types, 46-24
- systems, examples with PV, National Electrical Code, 45-66
- systems, Kingman, 24 VDC solar sub + 224 vac backup w/generator, 46-20
- Systems, pumping, PV & wind, for livestock, 57-24
- systems, Reichenbach; PV, generator, well, 42-18
- systems, troubleshooting wiring and pumps, 42-93
- wells, drilling, 33-54
- distillation, purifying sea water, 10-29
- two models of solar distillers, 36-62

## Water heating

- history, water heating history, 48-40
- Homebrew, solar, passive, simple black tube system, 11-19
- maintenance, anode replacement (letters), 47-100
- propane, test efficiency of hot water heater, 3-27
- solar, "shorties"; also wind, photovoltaics, rainwater, cogen, 20-50
- solar, active, geyser pump, Copper Cricket, 8-20
- solar, active, geyser, Copper Cricket, 21-43
- solar, active, overview, 25-37
- solar, active, Thermomax; Walker, 480 Wp, 12 V L-A, pump, 34-6
- solar, active; Simko, Whisper 1000, PV: 288 Wp, 36 V, 36-18

**Water heating continued**

solar, air & liquid collectors, basic types, also space heating, 40-36  
solar, basics, 27-42  
solar, basics, comparison of various systems, 19-35  
solar, economics, 27-64  
solar, economy solar shower (homebrew), 43-30  
solar, education, workshops, MREA, 47-74  
solar, Homebrew, economy solar shower, 43-30  
solar, passive, batch solar water heaters, 31-61  
solar, passive, batch, D'Angelo/CMC, 17-19  
solar, passive, coils of black ABS tubing, space heating, dome, 36-26  
solar, passive, simple black tube system, Homebrew, 11-19  
solar, passive, thermosiphon heat exchanger, 24-64  
solar, passive, thermosiphon system, 22-38  
solar, passive; Bridges, 470 Wp 12 V L-A, 12-5  
solar, passive; Stillman, 400 Wp, 24 V L-A, 22-6  
solar, Simko, also PV: 288 Wp, 36 V, also wind: Whisper 1000, 36-18  
solar, storage systems, diagrams, also space heating, 42-66  
Solar, system variables explored, 58-16  
solar, Thermomax; Schultze, PV/wind/hydro/DHW, 41-6  
solar, thermosiphon system, kid's project, 31-84  
Solar, thermosiphon, how to build, Homebrew, 58-30  
Systems, w/ PV, wind, & passive solar, Vogel, 56-6  
tanks, maintenance, anode replacement, source for, 45-30  
wood, heating water w/woodstove, 35-32  
wood, Simko, Whisper 1000, PV: 288 Wp, 36 V. hot water, 36-18  
wood, Simko; also wind, Whisper 1000; PV: 288 Wp, 36 V., 36-18  
wood, stove, 35-32

**Watt meters**

see "Instrumentation, watt meters"

**Watt-hour meters**

see "Instrumentation, watt-hour meters"

**Welding**

MigMaster DC Welder (TtW!), 30-62  
with photovoltaics, Battagin, 204 Wp, 24 V L-A, solar welding, manual tracker, 33-6

**Wind**

& PV, on sailboat, Cotterell, 53-12  
book reviews, Wind Power for Home and Business, 36-88  
education, workshops, MREA, 47-74  
generators, 10 compared/table, 35-20  
generators, 14 compared/table/graphs, glossary of terms, overview, 47-36  
generators, Bergey's BWC 1500 (TtW!), 29-46  
generators, blade balancing, 14-17  
generators, decibel level, 47-11  
generators, Homebrew, 1.5kW 24VDC; and tower, 42-38  
generators, Homebrew, 12-29  
generators, Homebrew, a guide to plans, 17-28  
generators, Marlec Furlmatic 910 (TtW!), 43-64  
generators, rewinding alternators for, 19-24  
generators, Rutland Windchargers (TtW!), 43-64  
generators, Whisper 1000 wind generator (TtW!), 20-42  
generators, Wincharger and Jacobs, 11-13  
generators, Windseeker II (TtW!), 14-15  
grounding, guidelines, 25-42  
grounding, lightning protection, 24-53  
history of wind generator use in U.S., 27-14  
Home built / restoration, , 56-32  
homebrew, Dailey, Cheap Towers, 52-24  
international, China, number of installed generators, 43-61  
intertie, Berger, 4 Kw, no batteries, 51-14  
odometers, Homebrew, 26-64  
odometers, NRG Sou'wester & 2100 Totalizer (TtW!), 28-55  
odometers, Trade Wind's Wind Odometer (TtW!), 22-53  
ordinances, in communities, sample, 47-12  
people, Elliott Bayly, founder, World Power Technologies, 43-58  
power politics, birds, 46-30  
resource across the US, map, table and references, 44-30  
system design, generators, 10 compared/table, 35-20  
system design, generators, 14 compared/table/graphs, glossary of terms, 47-36  
system design, generators, basics, 5-18  
system design, generators, overview of, hybrids, PURPA, 22-15  
system design, power formula, wind vs PV, 34-32  
system design, siting, 1-16  
system design, siting, how to estimate wind speed, 40-86  
system design, siting, Part 1, how to estimate wind speed, 40-86  
system design, siting, Part 2, nine rules, 41-60  
system design, siting, site survey: solar, hydro, and wind, 21-75

**Wind continued**

system design, towers, basics, 23-32  
system design, towers, Economics 101, 37-30  
system design, towers, Economics 102, height vs cost & performance, 38-27  
system design, towers, Economics 103, effects when not high enough, 39-26  
system design, towers, height, 21-64  
system, Islam, homebrewed, 2000W, Scotland, 52-20  
Systems (re-install), w/ PV, in CO, Preston, 58-6  
systems, Cunningham, wind water pump, PV, earth-sheltered dome, 38-6  
systems, Elliot, machine shop & home, photovoltaics; grid back-up, 38-16  
Systems, in Falkland Islands, Wilkinson, 55-18  
systems, Otto (MN); 10 kW; grid intertie, 47-6  
Systems, PV/Wind, Whitehead, 53-6  
systems, Schultze, Whisper 1000; photovoltaics/hydro/solar hot water, 41-6  
Systems, w/ PV & passive solar, Vogel, 56-6  
Systems, w/ PV, Hydro, BLM historical site, Bethea, 55-6  
Systems, w/PV, small scale, 57-6  
towers, Homebrew, utility pole & pipe tower, 28-26  
towers, Homebrew; also 1.5kW 24VDC generator, 42-38  
Towers, safety & maintenance, 57-18  
Towers, Tilt-up conversion of Rohn, 56-38  
Towers, tilt-up, LMW&S kit (TtW!), 58-50

**Wiring**

Ananda's Power Center IV (TtW!), 29-56  
Back to Basics, wire sizing table, 33-86  
batteries, basics/L-A & NiCd w/wiring diagrams, 27-30  
book reviews, Wiring 12 Volts For Ample Power, 20-61  
cables, build for battery/inverter, 7-36  
Code Corner, Standards, affects on cost & performance, 55-82  
connections, splicing, 14-36  
DC, sizing, table, voltage drop, applications, 14-32  
DC/photovoltaics, sizing, tables, 18-31  
Disconnects, Code Corner, 53-72  
Ground Fault Protection, PV systems Checklist, Code Corner, 58-82  
Guages, metric conversions, 57-98  
Homebrew, build cables for battery/inverter, 7-36  
inverters, wiring to mains panel, 11-23  
low voltage wiring techniques, sizing, 2-33  
NEC PV module wiring methods & cables, 51-86  
NEC, load circuits/wiring, 22-68  
photovoltaics, installing/wiring/mounting, 2-11  
photovoltaics, wiring non-identical panels, 27-22  
pumps, troubleshooting, 42-93  
SAFETY ALERT, Code Corner, ac multiwire branch circuits, 54-82  
tech notes, interconnects, 33-46  
wire sizing table, 33-86  
working with Romex cable, 27-38  
See also "Code Corner"

**Women**

Alternative building techniques, Home & Heart, 54-89  
see "People"  
systems, SELFs Solar Electricity for Rural Women, 50-6

**Wood gasification**

how to, safety of, 21-55  
intro to, 8-22

**Wood heat**

Log splitter, Homebrew, electric conversion, 55-32  
overview of masonry stoves, 51-42  
see "Space heating, wood" and "Water heating, wood"

**For information on receiving back issues  
of Home Power Magazine  
see page 81 in this issue**

or call

**800-707-6585**

**(919-475-0830 outside USA)**

**for availability, rates, specials,  
& back issues on CD ROM**

## Index to Advertisers

- A.C.I. — 69  
Abraham Solar — 38  
Adopt a Library — 71  
Advanced Composting Systems — 60  
Alternative Energy Engineering — 43  
American SunCo — 75  
American Wind Energy Association — 79  
APM Technology — 59  
BackHome Magazine — 92  
Backwoods Solar Electric Systems — 34 & insert 48  
Bergey Windpower — 41  
Bogart Engineering — 35  
BP Solar — 39  
BZ Products — 47 & 105  
C. Crane Company — 107  
China Farm Machinery — 38 & 79  
Communities Magazine — 34  
Cruising Equipment — 1  
Dankoff Solar Products — 27  
Delivered Solutions — IBC  
Electrathon America — 69  
Electrifying Solar Electric — 55  
Electro Automotive — 59 & 66  
Electron Connection — 61  
Energy Outfitters — 67  
Energy Systems & Design — 71  
Environmental Marketing — 35  
Exeltech — 12 & 28  
Feather River Solar Electric — 27 & 67  
Flett Homestead — 87  
Frontier Energy Systems — 67  
General Specialties — 33  
Geo Solar Works — 79  
Gimme Shelter — 107  
Great Northern Solar Systems — 103  
Harris Hydroelectric — 42  
Heart Interface — 1  
Heliotrope General — 110  
Hitney Solar Products — 60  
Home Power Back Issues — 80  
Home Power Biz Page — 81  
Home Power CD-ROM — 54  
Home Power Sub Form — 80  
Home Power T-Shirts — 55  
Horizon Industries — 74  
Hydrocap — 39  
Illowa Windworks — 39  
I-RENEW — 91  
Jack Rabbit Energy Systems — 55  
Johnson Electric — 69  
Kansas Wind Power — 60  
KTA — 60  
Lake Michigan Wind & Sun — 49  
Lepinski Homestead — 103  
Lil Otto Hydroworks — 74  
Low Keep Refrigeration — 48  
Lyncon Industries Inc. — 23  
Maple State Battery — 68  
Midway Labs — 80  
Midwest Renewable Energy Fair — 29  
Monolithic Constructors — 74  
Morningstar — 21  
Mountain Man Alternative Energy — 34  
MREA Workshops — 85  
Natural Energy Systems — 42  
New England Solar Electric, Inc. — 43  
Northwest Energy Storage — 13  
Offline — 69  
Photocomm — BC  
Planetary Systems — 48  
PV Network News — 75  
Quick Start REading Special — 92  
Rae Storage Batteries — 48  
Read your mailing label — 62  
Rexor Corporation — 35  
Rolls Battery Engineering—22  
Scott Andrews Videos — 85  
Sierra Solar — 75  
Simmons Handcrafts — 92  
Snorkel Stove Company — 42  
Solar Chef — 43  
Solar Depot — IFC  
Solar Electric Inc — 75  
Solar Energy International — 12, 23, 49, & 55  
Solar Industry Journal — 69  
Solar Pathfinder — 67  
Solar Plexus — 60  
Solar Village Institute — 21  
Solar Works — 48  
Southwest PV Systems — 22  
Southwest Windpower — 12  
Statpower — 23  
Sun Frost — 75  
Sun Wize — 28  
SunAmp Power Company — 67  
Sunelco — 5  
Sunpower — 79  
Talmage Solar Engineering — 48  
The New Electric Vehicles — 62  
Trace Engineering — 11  
Trojan — 27  
Wattsun (Array Tech Inc.) — 38  
Westco Battery — 42  
Wind & Sun — 54  
Windland — 67  
Windstream Power Systems — 48  
World Power Technologies — 28  
Zomeworks — 49







# HOME POWER

THE HANDS-ON JOURNAL OF HOME-MADE POWER

ISSUE #59

June / July 1997

\$4.75 U.S.

\$6.60 CAN.

Display until August 1



**PV/Utility Intertie**



**Hydrogen Storage**



**PV in Mexico**



**PV/Wind Earthship**



# LIVE WHERE YOU WANT TO LIVE AS REMOTE AS YOU WANT

*Complete Solar Power Systems. Ready to Generate Within Hours Of Delivery*



## LET SOLECTROGEN® BRING ELECTRIC POWER

WHERE YOU WANT IT  
WHERE YOU WANT IT  
WHERE YOU WANT IT  
WHERE YOU WANT IT  
WHERE YOU WANT IT  
WHERE YOU WANT IT  
WHERE YOU WANT IT  
WHERE YOU WANT IT  
WHERE YOU WANT IT  
WHERE YOU WANT IT  
WHERE YOU WANT IT  
WHERE YOU WANT IT  
WHERE YOU WANT IT  
WHERE YOU WANT IT  
WHERE YOU WANT IT

VISIT US ON THE WEB. [www.solardepot.com](http://www.solardepot.com) or email [staff@solardepot.com](mailto:staff@solardepot.com)





**Trace**  
ENGINEERING  
AUTHORIZED DISTRIBUTOR

SOLAR DEPOT  
SAN RAFAEL  
61 PAUL DR.  
(415) 499-1333  
(800) 822-4041  
FAX (415) 499-0316  
SAN RAFAEL, CA, 94903

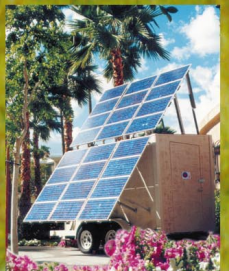

SOLAR DEPOT  
SACRAMENTO  
8605 FOLSOM BLVD.  
(916) 381-0235  
(800) 321-0101  
FAX (916) 381-2603  
SACRAMENTO, CA, 95826



  
**SOLAREX**  
AUTHORIZED DISTRIBUTOR